

HEAT SHRINK TUBES AND ACCESSORIES
CABLE JOINTS AND TERMINATIONS
CABLE ACCESSORIES

inspired by energy

TABLE OF CONTENTS

PROPERTIES

Radiation crosslinked polyolefin	5
----------------------------------	---

INSTALLATION MANUALS, TECHNICAL DETAILS AND OPERATIONAL PROPERTIES OF HEAT SHRINK TUBES

Installation of heat shrink tubes thin wall, medium wall and thick wall	6
Installation of heat shrink tube of large diameter on posts (renovation)	6
Technical details and operational properties of heat shrink tubes	

HEAT SHRINK THIN WALL TUBES

Heat shrink thin wall tubes, heat-resistant - type +125°C - typu RCH1	8
Heat shrink thin wall tubes, flexible, heat-resistant +125°C - type RCEH1	10
Heat shrink thin wall tubes, self-extinguishing, heat-resistant +125°C - type RCH1S	12
Heat shrink thin wall tubes, flexible, self-extinguishing, quick-shrink, heat-resistant +125°C - type RCEH1S	13
Heat shrink thin wall tubes, flexible, self-extinguishing, quick-shrink, heat-resistant +135°C - type RCEH2S	14
Polyolefin heat shrink tubes, very flexible, self-extinguishing, shrink ratio 3:1 and 4:1 - type RC3S and RC4S	16
Heat shrinkable tubes for thermotransfer printing, thin wall tubes, very flexible, self-extinguishing, halogen-free - type RC2S(HF), RC3S(HF)	17
Polyolefin heat shrink tubes, ultra thin - type RUC	18

THIN WALL TUBES WITH ADHESIVE

Thin wall heat shrink tubes, heat-resistant +125 +135°C with adhesive - type RCKH1 i RCEH2KS	19
Polyolefin heat shrink tubes, very flexible, adhesive-layered, shrink ratio 3:1, 4:1 - RC3K and RC4K	20

DIY HEAT SHRINK KITS

DIY Smallsters - type PRCH1-1, PRCH1-2, PRCH1-3	21
Mix of heat shrink tubes in phase colors - type RCH1	21
Thin wall tube on spools - type BOX	21
Cases - type ZDM	22
Stand with thin wall heat-resistants tubes - type KRCH1-2	22
Stand with medium wall, heat-resistants adhesive-layered tubes - type KRPKH1-1	23
Display stand with heat shrinkable accessories - type EOT1	23

MEDIUM WALL HEAT SHRINK TUBES

Medium wall heat shrink heat-resistant tubes +125°C - type RPH1, RPKH1, RPH1S, RPKH1S	24
Medium wall heat shrink tubes with mastic - type RPM	26

THICK WALL HEAT SHRINK TUBES

Heat shrink tubes of large diameters - type RDK, RDM, RD	27
Thick wall heat shrink tubes, adhesive-layered, high shrink ratio 6:1 - type RBG	29

TUBS AND TAPES FOR MEDIUM VOLTAGE

Medium wall heat shrink tubes, insulation, for Medium Voltage up to 36kV, anti-tracking - type RPAT	30
Medium and thick wall heat shrink tubes for Medium Voltage bus bar insulation - type RBM i RBH	33
Insulating tapes for bus bars - typu RTBB	32

TUBES OF SPECIAL MATERIALS

Heat shrink tubes of modified fluoroelastomer, very flexible - type RFE	33
Teflon heat shrink tubes - type RTE	34

HEAT SHRINK ACCESSORIES

Heat shrink breakout boots	
Heat shrink breakout boots: 2-core, 3-core, 4-core and 5-core - type AK	35
3-core heat shrink breakout boots for MV up to 36kV - type AKR	35
Heat shrink breakout boots - type AKR, AKB, AKF	36
Heat shrink sheds - type CES	37
Heat shrink cable end caps - type KTK	38
Heat shrink cable end caps - type KTM	39
Heat shrink protection kits for 0,6/1kV - type ZO 4, ZO	40
Heat shrink phase markers - type ZOK, ZOKzt	41
Heat shrink wall ducts - type TPM	41
Heat shrink repair wrap-arounds - type RM	42
Heat shrink tapes - type T, TK	42
Heat shrink pipe end caps - type „End-Cap“	43

TABLE OF CONTENTS
LOW VOLTAGE CABLE JOINTS nN 0,6/1kV

Straight cable joints for 0,6/1kV polymer insulated 4-core cables (without connectors)	44
Straight cable joints for 0,6/1kV polymer insulated 4-core cables (with Al connectors)	45
Straight cable joints for 0,6/1kV polymer insulated 4-core cables (with Cu connectors)	46
Straight cable joints for 0,6/1kV polymer insulated 4-core c (with screw connectors)	47
Straight cable joints for 0,6/1kV polymer insulated 1-core cables	48
Straight cable joints for 0,6/1kV polymer insulated 5-core cables	49
Straight cable joints for 0,6/1kV paper insulated cables	50
Straight cable joints for 0,6/1kV polymer insulated and armoured cables	51
Straight cable joints for 0,6/1kV traction cables	52
Straight cable joints 0,6/1kV for deep-well pumps	53
Straight cable joints for 0,6/1kV signal cable	54
Transition cable joints	55
Telecommunications cable joints - type GVAM	56
Straight cast resin joints 0,6/1kV - type JLZ	57
Branch cast resin joints 0,6 / 1kV - type JLZR1; 2; 3	58
Polyurethane resin, type RPU	60

MEDIUM VOLTAGE CABLE JOINTS SN 3,6/6kV, 6/10kV, 8,7/15kV, 12/20kV

Straight cable joints for 3-core unscreened polymer insulated cables 3,6/6kV	61
Straight cable joints for 3-core unscreened polymer insulated and armoured cables 3,6/6kV	62
Cable straight joints for 1-core unscreened armoured polymer insulated traction cables 3,6/6kV, 6/6kV	63
Straight cable joints for single-core screened polymer insulated cables with copper wire screen 6/10kV, 8,7/15kV, 12/20kV	64
Straight cable joints for 3-core screened saturated paper insulated and armoured cables with common metal sheath 3,6/6kV, 6/10kV	65
Straight cable joints for 3-core screened saturated paper insulated and armoured cables with common metal sheath 8,7/15kV, 12/20kV	66
Transition cable joints 3,6/6kV from 3-core polymer insulated cable to 3-core paper insulated c 3,6/6kV	67
Transition cable joints from 3-core screened saturated paper insulated and armoured cable with common metal sheath to three single core extruded and screened polymer insulated cables with copper wire screen	68
Straight cable joints for screened rubber insulated cables with three service cores and three protection cores	69
Straight cable joints for screened rubber insulated cables with three service cores and three protection cores	70

LOW VOLTAGE CABLE TERMINATIONS nN 0,6/1kV

Cable terminations for polymer insulated cables	71
Cable terminations for rubber insulated cables	72

MEDIUM VOLTAGE CABLE TERMINATIONS SN 3,6/6kV, 6/10kV, 8,7/15kV, 12/20kV

Indoor cable terminations for single-core unscreened polymer insulated cables with drain tapes	73
Indoor cable terminations for single-core unscreened polymer insulated cables with copper wire screen	74
Indoor cable terminations for 3-core unscreened polymer insulated cables with drain tapes	75
Indoor cable terminations for 3-core unscreened polymer insulated cables with copper wire screen	76
Outdoor cable terminations for 3-core unscreened polymer insulated cables with drain tapes	77
Outdoor cable terminations for 3-core unscreened polymer insulated cables with copper wire screen	78
Indoor cable terminations for 3-core unscreened polymer insulated and armoured cables with drain tapes	79
Outdoor cable terminations for 3-core unscreened polymer insulated and armoured cables with drain tapes or wire screen	80
Indoor cable termination for 1-core unscreened armoured polymer insulated traction cables	81
Outdoor cable termination for 1-core unscreened armoured polymer insulated traction cables	82
Indoor cable terminations for single-core screened polymer insulated cables with copper wire screen	83
Outdoor cable terminations for single-core screened polymer insulated cables with copper wire screen	84
Indoor cable terminations for 3-core saturated paper insulated and armoured cables with common metal sheath	85
Outdoor cable terminations for 3-core saturated paper insulated and armoured cables with common metal sheath	86
Indoor cable terminations for 3-core screened saturated paper insulated and armoured cables with common metal sheath	87
Outdoor cable terminations for 3-core screened saturated paper insulated and armoured cables with common metal sheath	88
Indoor cable terminations for screened rubber insulated wires with three service cores and three protection cores	89
Indoor cable terminations for screened rubber insulated wires with three service cores and three protection cores	90
Outdoor cable terminations for screened rubber insulated cables with three service cores and three protection cores	91
Indoor cable terminals for 3-core unscreened armoured polymer insulated power and mining cables with flame-retardant coating	92

EARTHING SETS

Earthing sets - paper insulated cables - type PEK	93
Earthing sets - polymer insulated cables - type PEK	94

TABLE OF CONTENTS

ALUMINUM CABLE TERMINALS

Aluminium thin-walled cable terminals - type 2 KAM	95
Aluminium cable terminals acc. to DIN standard, voltage up to 30kV - type D	96
Aluminium leakproof terminals acc. to DIN standard, voltage up to 30kV - type DKA	97
Aluminium thin-walled ferrules - type 2 ZA	98

ALUMINUM CABLE FERRULES

Aluminium ferrules acc. to DIN standard - type DZA	99
Aluminium ferrules with the partition acc. to DIN standard - type DZAP	100
Aluminium reducing ferrules acc. to DIN standard - type DZRA	101
Aluminium reducing ferrules with the leakproof partition acc. to DIN standard - type DZRAP	102
Aluminium reducing ferrules with the partition acc. to DIN standard, voltage up to 10 ÷ 30kV - type DZROAP	103
Aluminium ferrules, acc. to DIN standard, voltage up to 10 ÷ 30kV - type DZOA	104
Aluminium ferrules with the partition, acc. to DIN standard, voltage up to 10 ÷ 30kV - type DZOAP	105
Full-tension notch type midspan connectors - type of ferrules ZL	106
Full-tension notch type midspan connectors with spacer - type of ferrules ZLF, ZLFD	107

COPPER CABLE TERMINALS

Copper cable terminals - type K, KS	109
Copper cable terminals acc. to DIN standard, voltage up to 30kV - type DK, DKS	110
Angular copper cable terminals 45° - type KU, KUS	111
Angular copper cable terminals 45°, acc. to DIN standard, voltage up to 30kV - type DKU, DKUS	112
Angular copper cable terminals 90° - type KP, KPS	114
Angular copper cable terminals 90°, voltage up to 30kV, acc. to DIN standard - type DKP, DKPS	115
Insulated tinned spade terminals - type VI	117
Ring terminals - type LG, LS	118
Tinned and soldered ring terminals - type LZ	119
Insulated tinned ring terminals - type LI	120
Partially insulated tinned female connectors - type JB	121
Fully insulated tinned female connectors - type JC	122
Partially insulated tinned male connectors - type JE	123
Partially insulated tinned piggyback connectors - type JF	124
Total-insulation cable sleeves - type JP	125
Partial-insulation cable slides - type JR	126
Tinned sleeving terminals, not insulated - type AS	127
Tinned sleeving terminals, insulated - type AI	128
Tinned double sleeving terminals, insulated - type AI 2	129
Terminals with bolts, insulated PCV, tinned - type K	130
Copper cable ends, insulated - type JK	131

COPPER CABLE FERRULES

Copper cable ferrules - type Z, ZS	132
Copper cable ferrules acc. to DIN standard - type DZ, DZS	133
Copper cable ferrules with the partition acc. to DIN standard - type DZP, DZPS	134
Reducing copper cable ferrules acc. to DIN standard - type DZR, DZRS	135
Reducing copper cable ferrules acc. to DIN standard with leakproof partition - type DZRP, DZRPS	136
Copper cable ferrules for MV cables of 10 ÷ 30kV, acc. to DIN standard - type DZO, DZOS	137
Copper ferrules for mining cables - type ZG, ZGS	138
Tinned ferrules with hole - type ZCS	139
Butt connectors insulated - type ZKI	140
Copper butt connectors with shrinkable insulation with adhesive - type ZKIT	141
Copper cable ferrule with tin and heat-shrinkable insulation with adhesive - type ZKIC	142

ALUMINUM-COPPER CABLE TERMINALS

Aluminum-copper cable terminals, for voltages up to 30 kV, leakproof, acc. to DIN standard - type DKAMP	143
---	-----

TABLE OF CONTENTS

ALUMINUM-COPPER CABLE FERRULES

Aluminum-copper cable ferrules with leakproof partition, acc. to DIN standard - type DZAM	144
Aluminum-copper pins with leakproof partition, acc. to DIN standard - type DBAM	145
Aluminum-copper washers - type PC	146

SCREW-LIKE CABLE ENDS

Screw-like cable ends, tight, for voltage up to 36kV – SN ML36 t	147
Screw-like cable connectors, tight, for voltage up to 36 kV - SN MC36 type	148

12-WAY THREAD TERMINAL BLOCKS FOR WIRES

12-way thread terminal blocks for wires - type Z12T	149
---	-----

INSTALLATION CONNECTORS, QUICK COUPLIN

Installation connectors, quick couplings – SDK type	150
---	-----

FLOP CABLE GRIPS

For flat conductors fastening - type FP	151
For round conductors fastening - type FO	152
Pull apart pins - type KR1	153

QUICK ASSEMBLY HOLDE

Quick assembly holders for flat conductors - type USMP	154
Quick assembly holders for round conductors - type USMO	155
Hook quick assembly holders for pipes - type USMH	156

CABLE GRIPS AND HOLDERS

Retainers with assembly eye – UMD type	157
Collective cable holders - type UKZ	158
Cable hitching grips - type UP	160
All-purpose cable grips for cables and pipes - type U	161

CABLE TIES

Cable ties - type CT (white and black) - type CT	161
Reusable cable ties – CTK type	162
With assembly eye - type CTO	163
With snap grip - type CTZ	164
With outer identification plate - type CTTZ With inner identification plate - type CTTW	165

ELEMENTS FASTENED FOR CABLE TIES

Elements fastened in the hole drilled in the foundation - type UMW	166
Elements screwed down to the foundation with the aid of the screw - type UMO	167
Self-strick elements - type UMS	168

ELECTRO-INSULATING TAPES

Electro-insulating tapes - type	169
---------------------------------	-----

CABLE GLANDS

Cable glands, polyamide - type DR ... NP2	170
---	-----

TOOLS

Press: PMI 1-6, PMW 1-6, PMH 1-6, PMN 1-10	171
Press PMA 10-35	171

VIBROISOLATORS

Vibroisolators type UC	172
------------------------	-----

Radiation crosslinked polyolefin

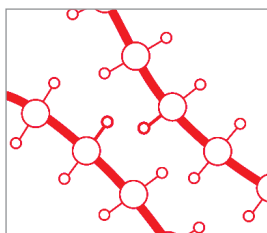

Polymer chains before crosslinking

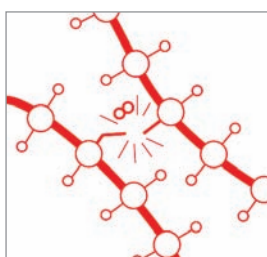

Splitting of hydrogen atoms during crosslinking

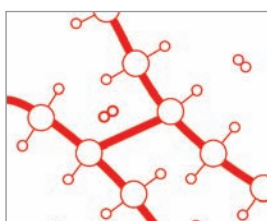

New stronger polymer bonds

What polyolefin is?

Polyolefin is made as an effect of polymerization of unsaturated hydrocarbons.

Among the mostly used polyolefins there are:

- Polyethylene (PE)
- Ethylene copolymer / vinyl acetate (EVA).

Kinds of PE

Linear low density polyethylene (LLDPE).

Low density polyethylene (LDPE).

Medium density polyethylene (MDPE).

High density polyethylene (HDPE).

Non-crosslinked polyethylene

Despite many advantages (goods dielectric properties, good mechanical and chemical properties, easiness in processing) non-crosslinked polyethylene has many disadvantages.

To improve its parameters (see the chart below), polyethylene should undergo the process of radiation crosslinking.

What the radiation crosslinking consist in?

This process consists in exposing material to the electron beams accelerated in vacuum up to the energy of several electron volts.

Thermoplastics, like polyethylene, are built of long irregular polymer chains. When exposed to radiation, two neighbouring chains make bonds in the places where hydrogen atoms split. This strong bond of chains is called "linked chains" (see the pictures at left).

The crosslinked polyethylene when heated to the temperature higher than crystal thawing, becomes soft and elastic, caoutchouc-like material. The non-crosslinked polyethylene would become ductile-fluid mass.

RADPOL S.A. is the only Polish company, which possesses an accelerator for industrial radiation crosslinking.

Shape memory

The crosslinked products obtain the property called "shape memory". This is the most interesting property of the heat shrink. The heat shrink may be shaped variously but when heated it shrinks down returning to its initial shape. This property is mainly used for insulation recovery.

For that purpose a crosslinked expanded heat shrink product with adhesive layer is put on the broken insulation and heated up. The new insulation layer shrinks down tightly on the place of repair. This method of repair and insulation is considered to be the most effective as far as the work costs and time and also life-length are concerned. Crosslinked heat shrink products are used for insulation, protection, anti-corrosion layers and decorative elements.

Comparison of non-crosslinked PE to radiation crosslinked PE

Non-crosslinked polyethylene	Radiation crosslinked polyethylene
in temperature over +120°C gets softened and thaws	in temperature over +120°C gets its initial form ("shape memory"), gets soft and flexible
maximum operation temperature up to +70°C	maximum operation temperature up to +135°C
does not resist thermal shock (over 4 hours)	withstands thermal shock up to +200°C (even up to +250°C)
susceptible for stress corrosion	fully stress corrosion resistant
low resistance to material creeping	high resistance to material creeping (in low temperatures)
resistant to chemical factors	resistant to aggressive chemical factors
soluble in solvents	almost non-soluble in solvents (susceptible for swelling)
low mechanical resistance	high mechanical resistance
resistant to incomplete discharge	highly resistant to incomplete discharges

Installation manuals

The installation of heat shrink products produced by RADPOL is quick and easy. In order to reach maximum satisfaction from the heat shrink products it is suggested to follow the instructions below.

Tools

The heat shrink products should be shrunk with hot-air blowers, gas heating torches and other equipment able to reach the temperature of over +120°C.

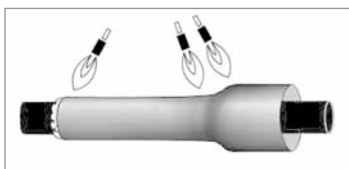
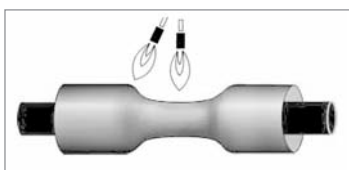

Installation of heat shrink tubes thin wall, medium wall and thick wall

Prepare the surface of the object on which the heat shrink tube will be installed

1. Un-dust and degrease the surface of the object, e.g. with a non-oil solvent.
2. The PVC cable surface should be ground with a piece of abrasive cloth and heated up.
3. Metal surfaces should be polished with abrasive cloth and heated up.

Prepare the heat shrink tube

1. Choose the tube with the required insulation parameters and diameter (the diameter of the recovered heat shrink tube should be smaller than the circumference of the object).

Shrinking

1. Slide the heat shrink tube.
2. Set the temperature of hot-air blower between +120°C and +200°C. The shrinking temperature should not exceed +200°C which could cause local overheating of the material.
3. Start the shrinking process from the middle of the tube with constant round movements around the tube to achieve steady shrink. The middle part of the tube should shrink down and stick closely to the object.
4. Shrink the ends of the tube with constant movements from the middle towards the ends. Properly shrunk tube should be smooth, with no bulges and notches.
5. If the installed tube is a double layer tube - with adhesive - the adhesive should flow out at the ends of the heat shrink tube.
6. Leave the shrunk tube to cool down.

Installation of heat shrink tube of large diameter on posts (renovation)

Prepare the post

1. Dismantle all the post's elements, e.g. lighting elements, for better heat shrink tube installment.
2. Clean and apply the ground coating on the bare part of the post.

Prepare the heat shrink tube

1. Choose the heat shrink tube with the required parameters and diameter.

Shrinking

1. Slide the heat shrink tube.
2. Set the temperature of hot air blower between +120°C and +200°C. The shrinking temperature should not exceed +200°C which could cause local overheating of the material.
3. Start the shrinking process from the bottom of the tube with constant round movements around the tube to achieve steady shrink. The bottom part of the tube should shrink down and stick closely to the object.
4. Shrink the other part of the tube with constant movements from the bottom up. Properly shrunk tube should be smooth, with no bulges and notches.
5. If the installed tube is a double layer tube - with adhesive - the adhesive should flow out at the ends of the heat shrink tube.
6. Leave the shrunk tube to cool down.

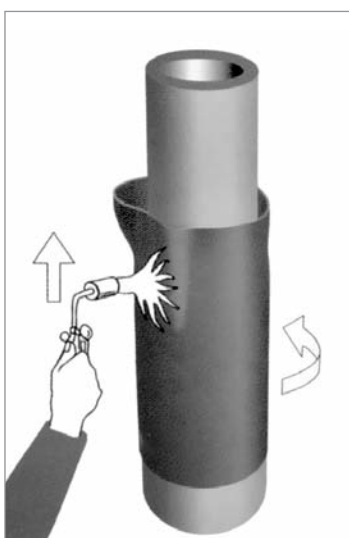

Installation of heat shrink breakout boots

Installation steps are the similar to installation of thin wall, medium wall and thick wall heat shrink tubes (see page 7).

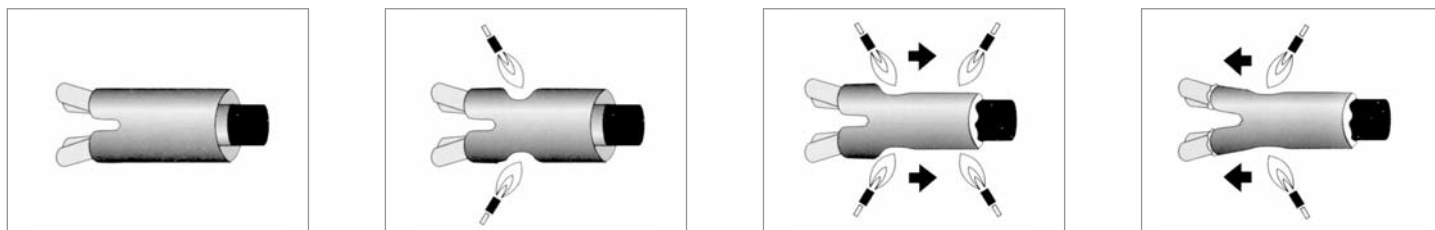
**Installation of heat shrink end caps**

Start the heating of the heat shrink end cap from the top of it towards the end. Keep the continuous movements of the heat torch or blower to gain the steady shrink. After proper installation the adhesive should flow out at the end of the end cap.

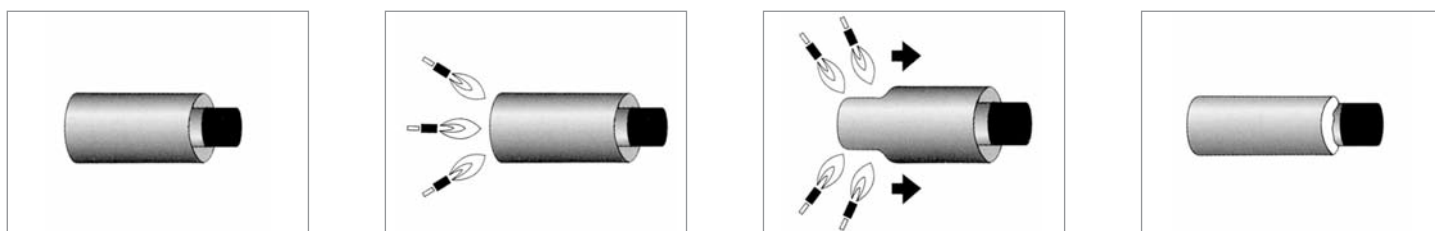
**Technical details and operational properties of heat shrink tubes****Material**

The heat shrink tubes by RADPOL are made of polyolefin (e.g. polyethylene) radiation crosslinked. They excellent insulate and seal. They play roles of protective layers, anti-corroding shields and decorative elements.

Used as a part of the final product they increase its technical level.

The heat shrink tubes protect against changing weather conditions and underground aggressive factors.

They make a very good protection against moist.

They adopt the shape of the object on which they are shrank and improve its mechanical protection.

Have very high shrink strength and unlimited storage time.

Nie podlegają korozji zmęczeniowej.

They don't undergo fatigue corrosion and are resistant to UV radiation, fungus, mould and other corrosive agents; urine, salts, majority of oils, petrol, alcohols and grease. The black tubes are UV radiation resistant.

They perform a cathodic protection function, involving the shift of the potential of the protected object (steel pipe) towards more negative potentials.

Colours

Standardowe kolory rur termokurczliwych cienkościennych, pogrubionych i grubościennych przedstawione zostały tabelarycznie (patrz strony 5 do 27).

The non-standard colours (eg. gray, fluorescent) are produced on request.

Heat shrink tubes of large diameters have black colour.

Lengths

Standard length is 1 meter.

Thin wall tubes - possibility on request of cutting into various length e.g. 2 cm, 20 cm etc. or producing on 50, 100, 300 m spools.

Medium, thick wall tubes and tubes of large dimensions to the size of 195/90 - possibility on request manufacturing longer than 1 meter.

The cutting of the tubes according to a demanded length must be done with a sharp tool, and the frontal surface of the cutted part should be equal, smooth, without burrs, etc.

On special demand we make tubes of different diameters and insulation properties.

We guarantee short realizations of non standard products' orders.

Shrink temperature

Shrink temperature is between +120°C to +200°C.

In case of temperature higher than +200°C, the overheating may occur.

Prtorage

Heat shrink products should be protected against direct sunray and stored in closed warehouses in temperatures between -10°C to +35°C.

Heat shrink thin wall tubes, heat-resistant - type +125°C - type RCH1

Application

Universal heat shrinkable tubes applied to perform electrical insulation, technical and moisture protection. They assume a shape of the object on which they are shrinking down, form a tightly adherent layer of an insulating, anticorrosion and decorative character.

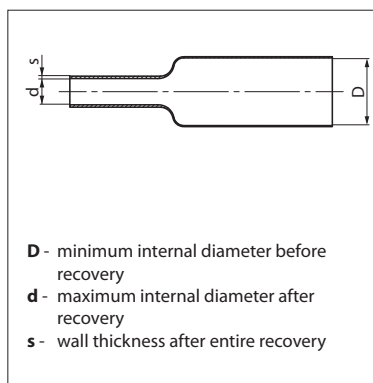

D - minimum internal diameter before recovery
d - maximum internal diameter after recovery
s - wall thickness after entire recovery



Operating temperature: -55 up to +125°C
 Shrink ratio: 2:1, 4:1
 The minimum shrink temperature: +115°C
 Colours: look below
 Not self-extinguishing, halogen-free
 UV resistant
 In accordance with REACH, RoHS

Tube type	Index	Dimensions [mm]			Packing [pcs. 1 m]	Spools [m]
		D	d	s		
shrink ratio: 2:1	(black color)					
RCH1 1,6 / 0,8	WRJCC1600080010030C1	1,6	0,8	0,45	100	100
RCH1 2,4 / 1,2	WRJCC2400120010030C1	2,4	1,2	0,5	100	100
RCH1 3,2 / 1,6	WRJCC3200160010030C1	3,2	1,6	0,5	100	100
RCH1 4,8 / 2,4	WRJCC4800240010030C1	4,8	2,4	0,5	100	100
RCH1 6,4 / 3,2	WRJCC6400320010030C1	6,4	3,2	0,6	100	100
RCH1 9,5 / 4,8	WRJCC9500480010030C1	9,5	4,8	0,6	100	100
RCH1 12,7 / 6,4	WRJCC1271640010030C1	12,7	6,4	0,6	100	100
RCH1 15,8 / 7,9	WRJCC1581790010030C1	15,8	7,9	0,8	50	100
RCH1 19 / 9,5	WRJCC1901950010030C1	19,0	9,5	0,9	50	100
RCH1 25,4 / 12,7	WRJCC2541127110030C1	25,4	12,7	0,9	50	100
RCH1 31,8 / 15,9	WRJCC3181159110030C1	31,8	15,9	1,0	50	50
RCH1 38 / 19	WRJCC3801190110030C1	38,0	19,0	1,1	50	50
RCH1 51 / 25,5	WRJCC5101255110030C1	51,0	25,5	1,1	40	25
RCH1 76 / 38	WRJCC7601380110030C1	76,0	38,0	2,3	20	25
RCH1 102 / 51	WRJCC1022510110030C1	102,0	51,0	2,0	20	25

Tube type	Index	Dimensions [mm]			Packing [pcs. 1 m]	Spools [m]
		D	d	s		
shrink ratio: 4:1	(black color)					
RCH1 4 / 1	WRJCC4000100010030C1	4,0	1,0	1,0	100	100
RCH1 8 / 2	WRJCC8000200010030C1	8,0	2,0	1,0	100	100

Standard length 1 meter. Tubes on spools are supplied round or flat up to dimension 12,7/6,4. Tubes on spools of larger dimensions than 12,7/6,4 are supplied flat. Tubes of other colors and length (cut into pieces) are supplied on special request.

Indexes: if you choose pipes with different colors, please replace the last two characters in the index black tubes (C1) on: D1 (red colour), E1 (blue), I1 (green), J1 (yellow), L1 (mix of colors), K1 (yellow-green), O1 (colorless), A1 (white), P1 (purple), B1 (brown), H1 (grey).

Examples of applications of heat shrink tubes

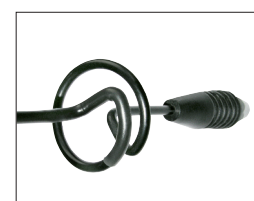
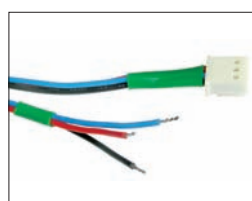
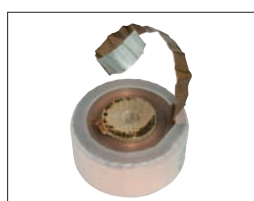

Properties	Test method	Tubes RCH1
Operating temperature		-55 up to +125°C
Length change after shrinking	EN 60684-2	+5 ÷ -10%
Tensile strength, min.	EN 60684-2	15MPa
Elongation at rupture, min.	EN 60684-2	350%
Heat ageing 168 hours	EN 60684-2	158°C
Tensile strength after heat ageing, min.	EN 60684-2	12MPa
Elongation at rupture after heat ageing, min.	EN 60684-2	250%
Heat shock (4 hours, temperature)	EN 60684-2	175°C no dripping, breaking and wall spreading
Contact with Cu after heat ageing (168 hours, temperature): elongation at rupture, min.	EN 60684-2	158°C: 100%
Cu corrosion	EN 60684-2	doesn't corrode
Cold bend; 4 hours	EN 60684-2	doesn't break in temp. -55°C
Flammability	EN 60684-2	firearms
Water absorptivity, max	ISO 62	0,1%
Dielectric resistance, min.	EN 60684-2; IEC 60243-1	16kV/mm
Volume resistivity, min.	EN 60684-2; IEC 60093	10 ¹² Ωm

Heat shrink thin wall tubes, flexible, heat-resistant +125°C - type RCEH1

Application Heat shrinkable tubes, flexible, rapidly shrinkable are used for insulating components that are sensitive to high temperatures, perfectly fit to the steel and aluminum components.

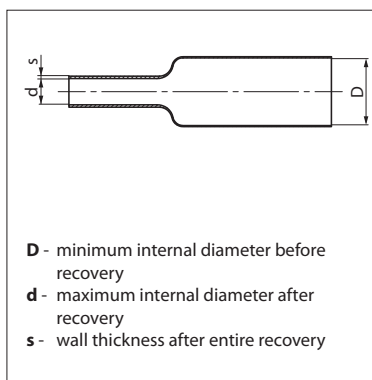

Operating temperature: -40 up to +125°C.
Shrink ratio: 2:1, 4:1
The minimum shrink temperature: +95°C
Colours: standard black, others on request
Do not self-extinguishing, halogen-free
UV resistant
In accordance with REACH, RoHS

Tube type	Index	Dimensions [mm]			Packing [pcs. 1 m]	Spools [m]
		D	d	s		
shrink ratio: 2:1	(black color)					
RCEH1 1,6 / 0,8	WRJCI1600080010030C1	1,6	0,8	0,45	100	100
RCEH1 2,4 / 1,2	WRJCI2400120010030C1	2,4	1,2	0,5	100	100
RCEH1 3,2 / 1,6	WRJCI3200160010030C1	3,2	1,6	0,5	100	100
RCEH1 4,8 / 2,4	WRJCI4800240010030C1	4,8	2,4	0,5	100	100
RCEH1 6,4 / 3,2	WRJCI6400320010030C1	6,4	3,2	0,6	100	100
RCEH1 9,5 / 4,8	WRJCI9500480010030C1	9,5	4,8	0,6	100	100
RCEH1 12,7 / 6,4	WRJCI1271640010030C1	12,7	6,4	0,6	100	100
RCEH1 19 / 9,5	WRJCI1901950010030C1	19,0	9,5	0,9	50	100
RCEH1 25,4 / 12,7	WRJCI2541127110030C1	25,4	12,7	0,9	50	100
RCEH1 38 / 19	WRJCI3801190010030C1	38,0	19,0	1,1	50	50
RCEH1 51 / 25,5	WRJCI5101255110030C1	51,0	25,5	1,1	40	50
RCEH1 76 / 38	WRJCI7601380110030C1	76,0	38,0	2,3	20	-
RCEH1 102 / 51	WRJCI1022510110030C1	102,0	51,0	2,0	20	-

Tube type	Index	Dimensions [mm]			Packing [pcs. 1 m]	Spools [m]
		D	d	s		
shrink ratio: 4:1	(black color)					
RCEH1 4 / 1	WRJCI4000100010030C1	4,0	1,0	1,0	100	100
RCEH1 8 / 2	WRJCI8000200010030C1	8,0	2,0	1,0	100	100

Standard length 1 meter. Tubes on spools are supplied round or flat up to dimension 12,7/6,4. Tubes on spools of larger dimensions than 12,7/6,4 are supplied flat. Tubes of other colors and length (cut into pieces) are supplied on special request.

Indexes: if you choose pipes with different colors, please replace the last two characters in the index black tubes (C1) on: D1 (red colour), E1 (blue), J1 (yellow), L1 (mix of colors), O1 (colorless), B1 (brown), F1 (orange).

Properties	Test method	Tubes RCEH1
Operating temperature		-40 up to +125°C
Length change after shrinking	EN 60684-2	+5 ÷ -10%
Tensile strength, min.	EN 60684-2	15 MPa
Elongation at rupture, min.	EN 60684-2	450%
Heat ageing 168 hours	EN 60684-2	158°C
Tensile strength after heat ageing, min.	EN 60684-2	13 MPa
Elongation at rupture after heat ageing, min.	EN 60684-2	300%
Heat shock (4 hours, temperature)	EN 60684-2	200°C no dripping, breaking and wall spreading
Contact with Cu after heat ageing (168 hours, temperature): elongation at rupture, min.	EN 60684-2	158°C 100%
Cu corrosion	EN 60684-2	doesn't corrode
Cold bend; 4 hours	EN 60684-2	doesn't break in temp. -40°C
Flammability	EN 60684-2	firearms
Water absorptivity, max	ISO 62	0,1%
Dielectric resistance, min.	EN 60684-2; IEC 60243-1	20kV/mm
Volume resistivity, min.	EN 60684-2; IEC 60093	10 ¹² Ωm

Examples of applications of heat shrink tubes



Heat shrink thin wall tubes, self-extinguishing, heat-resistant +125°C - type RCH1S

Application

Heat shrinkable tubes flame retardant used to perform an electrical insulation, bonding cable harnesses, provide mechanical shield and marking cables in the automotive and electronics industry, as well as in household appliances.

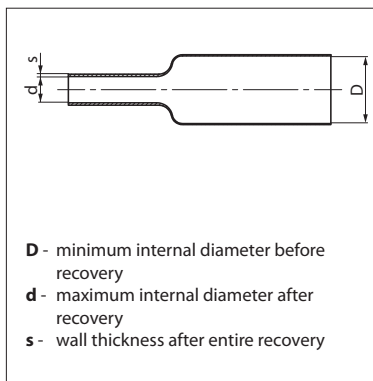

D - minimum internal diameter before recovery
d - maximum internal diameter after recovery
s - wall thickness after entire recovery



Operating temperature: -40 up to +125°C.
Shrink ratio: 2:1, 4:1
The minimum shrink temperature: +105°C
Colours: standard black, others on request
UV resistant: black color
Tubes self-extinguishing
In accordance with REACH, RoHS

Tube type shrink ratio: 2:1	Index (black color)	Dimensions [mm]			Packing [pcs. 1 m]	Spools [m]
		D	d	s		
RCH1S 1,6 / 0,8	WRJCE1600080010030C1	1,6	0,8	0,45	100	100
RCH1S 2,4 / 1,2	WRJCE2400120010030C1	2,4	1,2	0,5	100	100
RCH1S 3,2 / 1,6	WRJCE3200160010030C1	3,2	1,6	0,5	100	100
RCH1S 4,8 / 2,4	WRJCE4800240010030C1	4,8	2,4	0,5	100	100
RCH1S 6,4 / 3,2	WRJCE6400320010030C1	6,4	3,2	0,6	100	100
RCH1S 9,5 / 4,8	WRJCE9500480010030C1	9,5	4,8	0,6	100	100
RCH1S 12,7 / 6,4	WRJCE1271640010030C1	12,7	6,4	0,6	100	100
RCH1S 19 / 9,5	WRJCE1901950010030C1	19,0	9,5	0,9	50	100
RCH1S 25,4 / 12,7	WRJCE2541127110030C1	25,4	12,7	0,9	50	100
RCH1S 38 / 19	WRJCE3801190110030C1	38,0	19,0	1,1	50	50
RCH1S 51 / 25,5	WRJCE5101255110030C1	51,0	25,5	1,1	40	50
RCH1S 76 / 38	WRJCE7600380010030C1	76,0	38,0	2,3	20	-
RCH1S 102 / 51	WRJCI1022510110030C1	102,0	51,0	2,0	20	-

Tube type shrink ratio: 4:1	Index (black color)	Dimensions [mm]			Packing [pcs. 1 m]	Spools [m]
		D	d	s		
RCH1S 4 / 1	WRJCE4000100010030C1	4,0	1,0	1,0	100	100
RCH1S 8 / 2	WRJCE8000200010030C1	8,0	2,0	1,0	100	100

Standard length 1 meter. Tubes on spools are supplied round or flat up to dimension 12,7/6,4. Tubes on spools of larger dimensions than 12,7/6,4 are supplied flat. Tubes of other colors and length (cut into pieces) are supplied on special request.

Indexes: if you choose pipes with different colors, please replace the last two characters in the index black tubes (C1) on: D1 (red colour), E1 (blue), I1 (green), J1 (yellow), A1 (white), F1 (orange).

Properties	Test method	Tubes RCH1S
Operating temperature		-40 up to +125°C
Length change after shrinking	EN 60684-2	+5 ÷ -10%
Tensile strength, min.	EN 60684-2	10 MPa
Elongation at rupture, min.	EN 60684-2	200%
Heat ageing 168 hours	EN 60684-2	158°C
Tensile strength after heat ageing, min.	EN 60684-2	7 MPa
Elongation at rupture after heat ageing, min.	EN 60684-2	100%
Heat shock (4 hours, temperature)	EN 60684-2	200°C no dripping, breaking and wall spreading
Contact with Cu after heat ageing (168 hours, temperature): elongation at rupture, min.	EN 60684-2	158°C 100%
Cu corrosion	EN 60684-2	doesn't corrode
Cold bend; 4 hours	EN 60684-2	doesn't break in temp. -40°C
Flammability	EN 60684-2	self-extinguishing
Water absorptivity, max	ISO 62	0,5%
Dielectric resistance, min.	EN 60684-2; IEC 60243-1	16kV/mm
Volume resistivity, min.	EN 60684-2; IEC 60093	10 ¹² Ωm

Heat shrink thin wall tubes, flexible, self-extinguishing, quick-shrink, heat-resistant +125°C - type RCEH1S

Application

Heat shrinkable tubes used to perform electrical insulation in conditions requiring increased resistance to high temperatures.

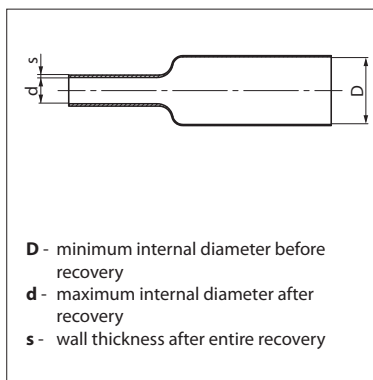

Operating temperature: -30 up to +125°C
Shrink ratio: 2:1, 4:1
The minimum shrink temperature: +90°C
Colours: standard black, others on request
UV resistant: black color
Tubes self-extinguishing
In accordance with REACH, RoHS

Tube type	Index (black color)	Dimensions [mm]			Packing [pcs. 1 m]	Spools [m]
		D	d	s		
RCEH1S 1,6 / 0,8	WRJCK1600080010030C1	1,6	0,8	0,45	100	100
RCEH1S 2,4 / 1,2	WRJCK2400120010030C1	2,4	1,2	0,5	100	100
RCEH1S 3,2 / 1,6	WRJCK3200160010030C1	3,2	1,6	0,5	100	100
RCEH1S 4,8 / 2,4	WRJCK4800240010030C1	4,8	2,4	0,5	100	100
RCEH1S 6,4 / 3,2	WRJCK6400320010030C1	6,4	3,2	0,6	100	100
RCEH1S 9,5 / 4,8	WRJCK9500480010030C1	9,5	4,8	0,6	100	100
RCEH1S 12,7 / 6,4	WRJCK1270640010030C1	12,7	6,4	0,6	100	100
RCEH1S 19 / 9,5	WRJCK1900950010030C1	19,0	9,5	0,9	50	100
RCEH1S 25,4 / 12,7	WRJCK2540127010030C1	25,4	12,7	0,9	50	100
RCEH1S 38 / 19	WRJCK3800190010030C1	38,0	19,0	1,1	50	50
RCEH1S 51 / 25,5	WRJCK5100255010030C1	51,0	25,5	1,1	40	50
RCEH1S 76 / 38	WRJCK7670380010030C1	76,0	38,0	2,3	20	-
RCEH1S 102 / 51	WRJCK1020510010030C1	102,0	51,0	2,0	20	-

Tube type	Index (black color)	Dimensions [mm]			Packing [pcs. 1 m]	Spools [m]
		D	d	s		
RCEH1S 4 / 1	WRJCK4000100010030C1	4,0	1,0	1,0	100	100
RCEH1S 8 / 2	WRJCK8000200010030C1	8,0	2,0	1,0	100	100

Standard length 1 meter. Tubes on spools are supplied round or flat up to dimension 12,7/6,4. Tubes on spools of larger dimensions than 12,7/6,4 are supplied flat. Tubes of other colors and length (cut into pieces) are supplied on special request.

Properties	Test method	Tubes RCEH1S
Operating temperature		-30 up to +125°C
Length change after shrinking	EN 60684-2	+5 ÷ -10%
Tensile strength, min.	EN 60684-2	12 MPa
Elongation at rupture, min.	EN 60684-2	200%
Heat ageing 168 hours	EN 60684-2	158°C
Tensile strength after heat ageing, min.	EN 60684-2	10 MPa
Elongation at rupture after heat ageing, min.	EN 60684-2	150%
Heat shock (4 hours, temperature)	EN 60684-2	250°C no dripping, breaking and wall spreading
Contact with Cu after heat ageing (168 hours, temperature): elongation at rupture, min.	EN 60684-2	158°C 100%
Cu corrosion	EN 60684-2	doesn't corrode
Cold bend; 4 hours	EN 60684-2	doesn't break in temp -30°C
Flammability	EN 60684-2	self-extinguishing
Water absorptivity, max	ISO 62	0,5%
Dielectric resistance, min.	EN 60684-2; IEC 60243-1	16kV/mm
Volume resistivity, min.	EN 60684-2; IEC 60093	10 ¹² Ωm

Heat shrink thin wall tubes, flexible, self-extinguishing, quick-shrink, heat-resistant +135°C - type RCEH2S

Application

Heat shrinkable tubes used to perform electrical insulation in conditions requiring increased resistance to high temperatures.



Standards UL224, 125°C, 600 V
Certificate Number E478953

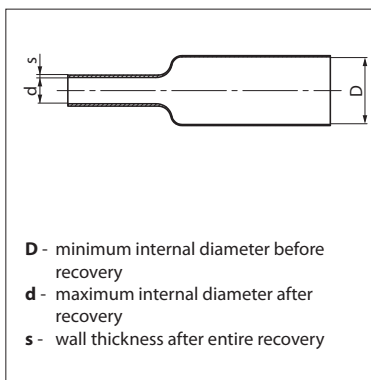

D - minimum internal diameter before recovery
d - maximum internal diameter after recovery
s - wall thickness after entire recovery



Operating temperature: -40 up to +135°C
Shrink ratio: 2:1, 4:1
The minimum shrink temperature: +90°C
Colours: standard black, others on request
UV resistant: black color
Tubes self-extinguishing
In accordance with UL, REACH, RoHS

Tube type shrink ratio: 2:1	Index (black color)	Dimensions [mm]			Packing [pcs. 1 m]	Spools [m]
		D	d	s		
RCEH2S 1,6 / 0,8	WRJCL1600080010030C1	1,6	0,8	0,5	100	100
RCEH2S 2,4 / 1,2	WRJCL2400120010030C1	2,4	1,2	0,5	100	100
RCEH2S 3,2 / 1,6	WRJCL3200160010030C1	3,2	1,6	0,5	100	100
RCEH2S 4,8 / 2,4	WRJCL4800240010030C1	4,8	2,4	0,5	100	100
RCEH2S 6,4 / 3,2	WRJCL6400320010030C1	6,4	3,2	0,6	100	100
RCEH2S 9,5 / 4,8	WRJCL9500480010030C1	9,5	4,8	0,6	100	100
RCEH2S 12,7 / 6,4	WRJCL1271640010030C1	12,7	6,4	0,6	100	100
RCEH2S 19 / 9,5	WRJCL1901950010030C1	19,0	9,5	0,9	50	100
RCEH2S 25,4 / 12,7	WRJCL2541127110030C1	25,4	12,7	0,9	50	100
RCEH2S 38 / 19	WRJCL3801190110030C1	38,0	19,0	1,1	50	50
RCEH2S 51 / 25,5	WRJCL5101255110030C1	51,0	25,5	1,1	40	50
RCEH2S 76 / 38	WRJCL7601380110030C1	76,0	38,0	2,3	20	-
RCEH2S 102 / 51	WRJCL1022510110030C1	102,0	51,0	2,0	20	-

Tube type shrink ratio: 4:1	Index (black color)	Dimensions [mm]			Packing [pcs. 1 m]	Spools [m]
		D	d	s		
RCEH2S 4 / 1	WRJCL4000100010030C1	4,0	1,0	1,0	100	100
RCEH2S 8 / 2	WRJCL8000200010030C1	8,0	2,0	1,0	100	100

Standard length 1 meter. Tubes on spools are supplied round or flat up to dimension 12,7/6,4. Tubes on spools of larger dimensions than 12,7/6,4 are supplied flat. Tubes of other colors and length (cut into pieces) are supplied on special request.



Properties	Test method UL224, EN 60684-2	Tubes RCEH2S
Operating temperature		-40 up to +135°C
Rated voltage	UL 224	600 V
Length change after shrinking	UL 224	±3%
Tensile strength, min.	UL 224	min. 10,4 MPa
Elongation at rupture, min.	UL 224	min. 200%
Secant module at elongation	UL 224	max. 175%
Heat shock (4 hours, temperature 250°C)	UL 224	no dripping, breaking and wall spreading
Heat ageing 168 hours	EN 60684-2	168 h, temperature 175°C
Tensile strength after heat ageing	UL 224	min. 7,3 MPa
Elongation at rupture after heat ageing, min.	UL 224	min. 200%
Cold bend (4 h, temperature -40°C)	UL 224	doesn't break in temp -40°C
Cu corrosion (168 h, temperature 158°C)	UL 224	doesn't corrode
Flammability (test wszystkie rury)	UL 224	self-extinguishing – max 30 sec
Dielectric resistance, min.	UL 224	min. 16kV/mm
Volume resistivity, min.	UL 224	min. 10 ¹⁴ Ωcm

Polyolefin heat shrink tubes, very flexible, self-extinguishing, shrink ratio 3:1 and 4:1 - type RC3S and RC4S

Application

RC3S: wide application in the performance of electrical insulation, connecting cable bundles and marking to protect against corrosion and to provide mechanical shield.

Shrink ratio 3:1 is more suitable for applications in irregular shapes.

RC4S: widely used in the military, aircraft and electronics industry. Also applied to insulate and repair of wire, cable and line bundles.

Pipes are manufactured using a special utility and technology formula. It is easy to slide on a large diameter and after shrink down on a small diameter of connector or transition.

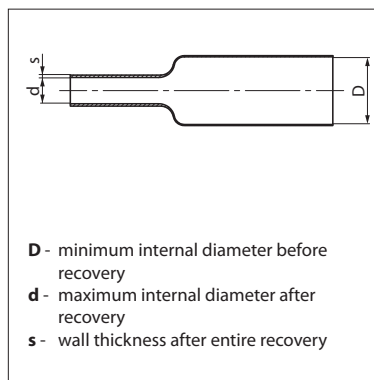

Operating temperature: -55 up to +135°C
Shrink ratio: 3:1, 4:1
The minimum shrink temperature: +70°C
Standard colours: black
Tubes self-extinguishing

Tube type <i>shrink ratio: 2:1</i>	Index (black color)	Dimensions [mm]			Standard length of the spool [m]
		D	d	s	
RC3S 1,6 / 0,5	TRJHL1600050020050C1	1,6	0,5	0,45	200
RC3S 3,2 / 1	TRJHL3200100020050C1	3,2	1,0	0,55	200
RC3S 4,8 / 1,5	TRJHL4800150010050C1	4,8	1,5	0,60	100
RC3S 6,4 / 2	TRJHL6400200010050C1	6,4	2,0	0,65	100
RC3S 9,5 / 3	TRJHL9500300010050C1	9,5	3,0	0,75	100
RC3S 12,7 / 4	TRJHL1271400050020C1	12,7	4,0	0,80	50
RC3S 19,1 / 6	TRJHL1911600050040C1	19,1	6,0	0,90	50
RC3S 25,4 / 8	TRJHL2541800050040C1	25,4	8	1,00	50
RC3S 39 / 13	TRJHL3901130150040C1	39,0	13	1,25	50

Tube type <i>shrink ratio: 4:1</i>	Index (black color)	Dimensions [mm]			Packing [pcs. 1 m]	Cut in lengths [m]
		D	d	s		
RC4S 19,1 / 4,6	TRJHL1911460012230C1	19,1	4,6	1,7	50	1,22
RC4S 25,4 / 7	TRJHL2541700012230C1	25,4	7,0	1,7	50	1,22
RC4S 38,1 / 9,5	TRJHL3811950012230C1	38,1	9,5	1,7	50	1,22
RC4S 50,8 / 14	TRJHL5081140112230C1	50,8	14,0	1,7	20	1,22

Properties	Test method	Tubes RC3S / RC4S
Tensile strength	ASTM D 2671	14 MPa
Elongation at rupture	ASTM D 2671	800%
Tensile strength after heat ageing, (+175°C, 168 h)	ASTM D 2671	14 MPa
Elongation at rupture after heat ageing (+175°C, 168 h)	ASTM D 2671	350%
Attempt of flammability	UL 224 VW1, SAE-AMS-DTL-23053/5	positive
Heat shock (+250°C, 4 h)	ASTM D 2671	no breaking
Cold bend test (-55°C, 4 h)	ASTM D 2671	no breaking
Dielectric resistance	ASTM D 150	20kV/mm
Volume resistivity	ASTM D 876	10 ¹⁴ Ωm
Cu corrosion	UL 224	doesn't corrode
Water absorptivity	ASTM D 570	0,15%
Chemical resistance	SAE-AMS-DTL-23053/5	positive
Length change after shrinking	UL 224	0 ±5

Heat shrinkable tubes for thermotransfer printing, thin wall tubes, very flexible, self-extinguishing, halogen-free - type RC2S(HF), RC3S(HF)



Application

Specially prepared surface of heat shrink tubing ensures high quality printing by thermotransfer printer.

In this way you can mark any wire, cable, and finally improve the safety of its operation. Tubes recommended for insulating wires, cables do not contain halogen, used in automotive, rail, aircraft, shipbuilding industry. Pipe surface suitable for printing by thermal transfer printer. Pipes flattened, self-extinguishing, halogen-free, low smoke emission during combustion.

Operating temperature:	-55 up to +105°C
Shrink ratio:	2:1, 3:1
The minimum shrink temperature:	+70°C
Standard colours:	white, yellow, others on request
In accordance with REACH, RoHS	

Tube type shrink ratio: 2:1	Index (white color)	Index (yellow color)	Dimensions [mm]			Standard length of the spool [m]
			D	d	s	
RC2S(HF) 2,4/1,2	TRJBH2400120010050AT	TRJBH2400120010050JT	2,4	1,2	0,48-0,52	100
RC2S(HF) 3,2/1,6	TRJBH3200160010050AT	TRJBH3200160010050JT	3,2	1,6	0,52-0,56	100
RC2S(HF) 4,8/2,4	TRJBH4800240010050AT	TRJBH4800240010050JT	4,8	2,4	0,54-0,58	100
RC2S(HF) 6,4/3,2	TRJBH6400320010050AT	TRJBH6400320010050JT	6,4	3,2	0,54-0,58	100
RC2S(HF) 9,5/4,8	TRJBH9500480010050AT	TRJBH9500480010050JT	9,5	4,8	0,60-0,64	100
RC2S(HF) 12,7/6,4	TRJBH1271640010050AT	TRJBH1271640010050JT	12,7	6,4	0,62-0,66	100
RC2S(HF) 19/9,5	TRJBH1901950010050AT	TRJBH1901950010050JT	19	9,5	0,62-0,66	100

Tube type shrink ratio: 3:1	Index (white color)	Index (yellow color)	Dimensions [mm]			Standard length of the spool [m]
			D	d	s	
RC3S(HF) 3,2/1,1	TRJBH3200110010050AT	TRJBH3200110010050JT	3,2	1,1	0,45-0,48	100
RC3S(HF) 4,8/1,6	TRJBH4800160010050AT	TRJBH4800160010050JT	4,8	1,6	0,48-0,52	100
RC3S(HF) 6,4/2,1	TRJBH6400210010050AT	TRJBH6400210010050JT	6,4	2,1	0,50-0,54	100
RC3S(HF) 9,5/3,1	TRJBH9500310010050AT	TRJBH9500310010050JT	9,5	3,1	0,62-0,66	100
RC3S(HF) 12,7/4,2	TRJBH1271420010050AT	TRJBH1271420010050JT	12,7	4,2	0,63-0,68	100
RC3S(HF) 19,1/6,3	TRJBH1911630010050AT	TRJBH1911630010050JT	19,1	6,3	0,82-0,88	100

Properties	Test method	Tubes RC2S(HF) / RC3S(HF)
Length change after shrinking	UL 224	-6%
Tensile strength	ASTM D 2671	14 MPa
Elongation at rupture	ASTM D 2671	400%
Tensile strength after heat ageing (158°C, 168 h)	ASTM D 2671	12 MPa
Elongation at rupture after heat ageing (158°C, 168 h)	ASTM D 2671	350%
Heat shock (+250°C, 4 h)	UL 224	no breaking and wall spreading
Dielectric resistance test (2500V, 1min)	UL 224	no breaking
Volume resistivity	IEC 93	10 ¹⁴ Ωm
Cu corrosion	UL 224	doesn't corrode
Flammability	UL 224	in line
Adhesion printing	SAE-AS-81532 4.6.2	positive
Printing solvent resistance	MIL-STD-202F Method 215	positive

Polyolefin heat shrink tubes, ultra thin - type RUC

Application

Especially recommended in areas where it has meaning of fast shrinking and space savings.

The low shrink temperature reduces installation time and risk of damaging components sensitive to temperature.

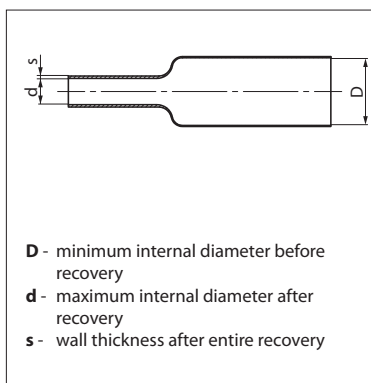

Operating temperature: from -55°C up to +125°C
Shrink ratio: 2:1
Minimum shrink temperature: +70°C
Standard colours: black color
Self-extinguishing polyolefin tubes
Environment-friendly
Ultra thin and flexible

Tube type	Index	Dimensions [mm]			Standard length of the spool [m]
		D	d	s	
RUC 1,4/0,6	TRJHU1400060020050C1	1,4	0,6	0,20	200
RUC 1,9/0,8	TRJHU1900080010050C1	1,9	0,8	0,20	100
RUC 3/1,2	TRJHU3000120010050C1	3,0	1,2	0,25	100
RUC 3,5/1,6	TRJHU3500160010050C1	3,5	1,6	0,25	100
RUC 5,5/2,4	TRJHU5500240010050C1	5,5	2,4	0,25	100
RUC 6,5/3,2	TRJHU6500320010050C1	6,5	3,2	0,28	100
RUC 10,5/ 4,8	TRJHU1051480010050C1	10,5	4,8	0,28	100
RUC 13,5/6,4	TRJHU1351640050040C1	13,5	6,4	0,28	50

Properties	Test method	Tubes RUC
Operating temperature:	IEC 216	-55 do +125°C
Tensile strength	ASTM D 2671	> 14 MPa
Elongation at rupture	ASTM D 2671	> 400%
Length change after shrinking	UL 224	0 ±5%
Elongation at rupture after heat ageing	158°C, 168 h	> 300%
Inflammability test	VW-1	positive
Dielectric resistance	IEC 243	> 20kV/mm
Volume resistivity	IEC 93	> 10 ¹⁴ Ωcm
Influence on copper	ASTM D 2671	doesn't corrode

Thin wall heat shrink tubes, heat-resistant +125 +135°C with adhesive - type RCKH1 i RCEH2KS

Application

Heat shrinkable tubes with adhesive layer protect against water and moisture also among others cables and other cable bundles exposed to moisture penetration.

They are also used in the performance and repair of electrical insulation, connecting cable bundles and as protection against corrosion.

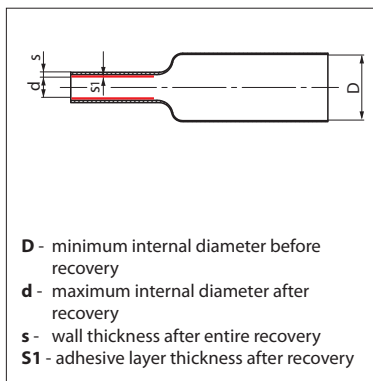

D - minimum internal diameter before recovery
d - maximum internal diameter after recovery
s - wall thickness after entire recovery
S1 - adhesive layer thickness after recovery



Operating temperature:
 Tubes self-extinguishing:
 Tubes halogen-free:
 Shrink ratio:
 Minimum shrink temperature:
 Colours:
 UV resistant
 In accordance with REACH, RoHS

RCKH1 -25 up to +125°C*, RCEH2KS -30 up to +135°C* *outer layer
 only RCEH2KS
 only RCKH1
 3:1, 4:1.
 +115°C.
 look below
 black color

Thin wall tubes with adhesive, heat-resistant +125°C - RCKH1

Tube type	Index (black color)	Dimensions [mm]			Adhesive layer thickness after recovery [mm] - S1	Packing [pcs. 1 m]
		D	d	s		
RCKH1 3 / 1	WRDCC300010011003KC1	3	1	1,0	0,40	10
RCKH1 4 / 1	WRDCC400010001003KC1	4	1	1,0	0,40	10
RCKH1 6 / 2	WRDCC600020001003KC1	6	2	1,2	0,50	10
RCKH1 8 / 2	WRDCC800020001003KC1	8	2	1,2	0,50	10
RCKH1 12 / 3	WRDCC120130001003KC1	12	3	1,2	0,50	10

Standard length 1 meter. Mixed - tubes of 5 different colors. Tubes of other colors and length (cut into pieces) are supplied on special request.
Indexes: if you choose pipes with different colors, please replace the last two characters in the index black tubes (C1) on: **D1** (red colour), **E1** (blue), **I1** (green), **J1** (yellow), **L1** (mix of colors), **O1** (colorless).

Thin wall tubes with adhesive, heat-resistant +135°C, self-extinguishing, flexible, quick-shrink - RCEH2KS

Tube type	Index (black color)	Dimensions [mm]			Adhesive layer thickness after recovery [mm] - S1	Packing [pcs. 1 m]	Spools [m]
		D	d	s			
RCEH2KS 3 / 1	WRDCL300010001003KC1	3	1	1,0	0,4	10	100
RCEH2KS 4 / 1	WRDCL400010001003KC1	4	1	1,0	0,4	10	100
RCEH2KS 6 / 2	WRDCL600020001003KC1	6	2	1,2	0,5	10	100
RCEH2KS 8 / 2	WRDCL800020001003KC1	8	2	1,2	0,5	10	100
RCEH2KS 12 / 3	WRDCL120130001003KC1	12	3	1,2	0,5	10	100

Properties	Test method	Tubes RCKH1	Tubes RCEH2KS
Operating temperature		-25 up to +125°C*	-30 up to +135°C* *outer layer
Length change after shrinking	EN 60684-2	+5 ÷ -10%	+5 ÷ -10%
Tensile strength, min.	EN 60684-2	15 MPa	12 MPa
Elongation at rupture, min.	EN 60684-2	350%	350%
Heat ageing 168 hours	EN 60684-2	158°C	175°C
Tensile strength after heat ageing, min.	EN 60684-2	12 MPa	10 MPa
Elongation at rupture after heat ageing, min.	EN 60684-2	250%	200%
Heat shock (4 hours, temperature)	EN 60684-2	175°C no dripping, breaking and wall spreading	250°C
Contact with Cu after heat ageing (168 hours, temperature): elongation at rupture, min.	EN 60684-2	158°C 100%	160°C 100%
Cu corrosion	EN 60684-2	doesn't corrode	
Cold bend; 4 hours	EN 60684-2	doesn't break in temp. -55°C	doesn't break in temp. -30°C
Flammability	EN 60684-2	firearms	self-extinguishing
Water absorptivity, max	ISO 62	0,1%	0,5%
Dielectric resistance, min.	EN 60684-2; IEC 60243-1	16kV/mm	16kV/mm
Volume resistivity, min.	EN 60684-2; IEC 60093	10 ¹² Ωm	10 ¹² Ωm

Polyolefin heat shrink tubes, very flexible, adhesive-layered, shrink ratio 3:1, 4:1 - RC3K and RC4K

Application

Designed for making protection on cable bundles and metal pipes against water and moisture.

They make both good insulation and sealing.

Manufactured by coextruding of polyolefin and a hotmelt.

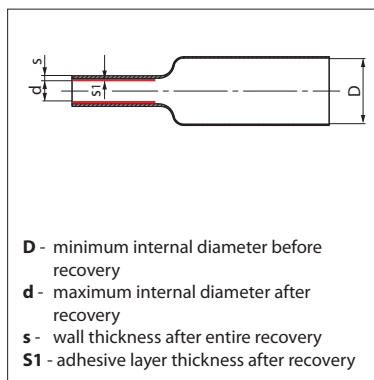

Operating temperature: from -45 up to +125°C
Shrink ratio: 3:1, 4:1
Minimum shrink temperature: +80°C
Standard colour: black
Outer shell - self-extinguishing (except a colorless)

Tube type shrink ratio: 3:1	Index (black color)	Dimensions [mm]			Adhesive layer thickness after recovery [mm] - S1	Standard length of the spool [m]
		D	d	s		
RC3K 3 / 0,6	TRDHL300006002005KC1	3,0	0,6	1,0	0,50	200
RC3K 4,8 / 1,5	TRDHL480015001005KC1	4,8	1,5	1,1	0,50	100
RC3K 6 / 2	TRDHL600020001005KC1	6,0	2,0	1,2	0,50	100
RC3K 9 / 3	TRDHL900030005004KC1	9,0	3,0	1,3	0,60	50
RC3K 12 / 4	TRDHL120140002504KC1	12,0	4,0	1,7	0,80	25
RC3K 19 / 6	TRDHL190160002504KC1	19,0	6,0	2,0	0,80	25
RC3K 24 / 8	TRDHL240180002504KC1	24,0	8,0	2,2	1,05	25
RC3K 30 / 10	TRDHL300110011223KC1	30,0	10,0	2,4	1,05	Cut into 1,22 m
RC3K 40 / 13	TRDHL400113012504KC1	40,0	13,0	2,5	1,05	25
RC3K 50 / 19	TRDHL500119011223KC1	50,0	19,0	2,5	1,05	Cut into 1,22 m

Tube type shrink ratio: 4:1	Index (black color)	Dimensions [mm]			Adhesive layer thickness after recovery [mm] - S1	Standard length of the spool [m]
		D	d	s		
RC4K 4 / 1	TRDHL400010001005KC1	4	1,00	1,00	0,50	100
RC4K 6 / 1,27	TRDHL600012701005KC1	6	1,27	1,20	0,60	100
RC4K 8 / 1,65	TRDHL800016505004KC1	8	1,65	1,55	0,75	50
RC4K 12 / 2,41	TRDHL120124102504KC1	12	2,41	1,95	1,00	25
RC4K 16 / 4	TRDHL160140002504KC1	16	4,00	2,10	1,05	25
RC4K 18 / 4,45	TRDHL180144502504KC1	18	4,45	2,40	1,20	25
RC4K 24 / 6	TRDHL240160002504KC1	24	6,00	2,50	1,25	25
RC4K 32 / 8	TRDHL320180002504KC1	32	8,00	2,50	1,25	25
RC4K 52/13	TRDHL520113011223KC1	52	13,00	2,50	1,25	Cut into 1,22 m

Properties	Test method	Tubes RC3K / RC4K
Tensile strength	ASTM D 2671	minimum 10,4 MPa
Tensile strength after heat ageing (+158°C, 168 h)	ASTM D 2671	remains 70%
Elongation at rupture	ASTM D 2671	minimum 200%
Length change after shrinking	UL 224	0 -10%
Heat shock (+250°C, 4 h)	ASTM D 2671	no cracks
Cold bend (-30°C, 1 h)	ASTM D 2671	no cracks
Voltage test AC (2500 V, 60 s)	ASTM D 2671	No breakdowns
Volume resistivity	ASTM D 876	minimum 10 ¹⁴ Ωcm
Inflammability test	SAE-AMS-DTL-23053/5	self-extinguishing after 30 s
Influence on copper (+158°C, 168 h)	UL 224	no corrosion

DIY Smallsters - type PRCH1-1, PRCH1-2, PRCH1-3

Application

Meant for electricians, car fitters, handymen and other users who need handy sets of heat shrink tubes to DIY works. Sets consist of different colors short length tubes.

Type of Smallster	Index	Type	Heat shrink tubes		Packing Quantity [set]
			Length [mm]	Quantity [pcs]	
PRCH1-1	WET0011	RCH1 2,4 / 1,2	50	6	10
		RCH1 3,2 / 1,6	50	6	
		RCH1 4,8 / 2,4	50	5	
		RCH1 6,4 / 3,2	50	5	
PRCH1-2	WET0021	RCH1 4,8 / 2,4	70	5	10
		RCH1 6,4 / 3,2	70	5	
		RCH1 9,5 / 4,8	70	3	
		RCH1 12,7 / 6,4	70	3	
PRCH1-3	WET0031	RCH1 2,4 / 1,2	90	6	10
		RCH1 3,2 / 1,6	90	6	
		RCH1 4,8 / 2,4	90	6	
		RCH1 6,4 / 3,2	90	6	
		RCH1 9,5 / 4,8	90	6	
		RCH1 12,7 / 6,4	90	6	



Mix of heat shrink tubes in phase colors - type RCH1

Application

One package contains most popular colors used by fitters and electricians (50 m of each dimension).

Type of tube	Index	Mix of phase colors Quantity [szt. 1 m]				
		black	brown	blue	red	yellow-green
RCH1 6,4/3,2x1-MF	WRJCC640032000000T1	20	10	10	5	5
RCH1 8/2x1-MF	WRJCC8000200010030T1	20	10	10	5	5
RCH1 9,5/4,8x1-MF	WRJCC9500480010030T1	20	10	10	5	5
RCH1 12,7/6,4x1-MF	WRJCC1271640010030T1	20	10	10	5	5
RCH1 19/9,5x1-MF	WRJCC1901950010030T1	20	10	10	5	5
RCH1 25,4/12,7x1-MF	WRJCC2541127110030T1	20	10	10	5	5
RCH1 38/19x1-MF	WRJCC3801190110030T1	20	10	10	5	5



Thin wall tube on spools - type BOX

Application

Thin wall heat shrink tubes supplied on spools in convenient boxes. You may cut a piece of tube to whatever length is needed.

Type of tube	Index	Dimensions [mm]			Spool [m]
		D	d	s	
BOX RCH1 1,6/0,8x20-C	WRJCC1600080020040C1	1,6	0,8	0,45	20
BOX RCH1 2,4/1,2x20-C	WRJCC2400120020040C1	2,4	1,2	0,5	20
BOX RCH1 3,2/1,6x20-C	WRJCC3200160020040C1	3,2	1,6	0,5	20
BOX RCH1 4/1x10-C	WRJCC4000100010040C1	4,0	1,0	1,0	10
BOX RCH1 4,8/2,4x10-C	WRJCC4800240010040C3	4,8	2,4	0,5	10
BOX RCH1 6,4/3,2x10-C	WRJCC6400320010040C2	6,4	3,2	0,6	10
BOX RCH1 8/2x10-C	WRJCC8000200010040C2	8,0	2,0	1,0	10
BOX RCH1 9,5/4,8x10-C	WRJCC9500480010040C2	9,5	4,8	0,6	10
BOX RCH1 12,7/6,4x10-C	WRJCC1271640010040C2	12,7	6,4	0,6	10
BOX RCH1 19/9,5x5-C	WRJCC1901950050030C2	19	9,5	0,9	5
BOX RCH1 25,4/12,7x5-C	WRJCC2541127150030C2	25,4	12,7	0,9	5



Cases - type ZDM

Elements sets are packed in a handy cassette with dimensions 210 x 105 x 50 mm.

Standard colour - black.

Other colors - available on request.

Properties - see table technical and operational properties of heat shrink tubes.



Content	Type of element	Set ZDM 1 Index WET010		Set ZDM 2 Index WET012		Set ZDM 3 Index WET014	
		Length [mm]	Quantity [pcs]	Length [mm]	Quantity [pcs]	Length [mm]	Quantity [pcs]
Heat shrink tube	RCH1 1,6 / 0,8	-	-	55	60	55	30
	RCH1 2,4 / 1,2	95	60	55	30	55	20
	RCH1 3,2 / 1,6	95	40	55	25	55	14
	RCH1 4,8 / 2,4	95	24	55	15	55	10
	RCH1 6,4 / 3,2	95	14	100	15	100	14
	RCH1 12,7 / 6,4	95	2	100	8	100	5
	RCH1 19 / 9,5	95	2	100	3	100	5
	RCH1 25,4 / 12,7	95	2	-	-	-	-
	RCH1 2,4 / 1,2	195	3	-	-	-	-
	RCH1 3,2 / 1,6	195	2	-	-	-	-
	RCH1 4,8 / 2,4	195	3	-	-	-	-
	RCH1 6,4 / 3,2	195	2	-	-	-	-
	RCH1 9,5 / 4,8	195	1	100	8	100	8
	RCH1 12,7 / 6,4	195	1	-	-	-	-
	RPH1 12 / 4	-	-	100	6	100	4
Copper cable lug	K 2,5/4	-	-	-	10	-	-
	K 6/5	-	-	-	-	-	10
Copper ring cable lug	LS 6/5	-	-	-	-	-	10
Copper connection lugs	flat male copper lug	-	-	-	10	-	10
	flat female copper lug	-	-	-	10	-	10
Copper compression connector	ZS 2,5	-	-	-	-	-	20
	ZS 4	-	-	-	-	-	20
Tin and resin		-	-	1000	1	1000	1

Stand with thin wall heat-resistants tubes - type KRCH1-2



Comfortable and nice-looking stand for warehouses, mega stores and shops contains a set of standard thin wall heat shrink tubes and adhesive-layered ones of various diameters and colours.

New more durable package made of moisture-proof polypropylene material exposes perfectly the variety of heat shrink tube offer.

Additional dimension of heat shrink tube in the set RCKH1 (with adhesive) in short distances (0.5 m).

Index: WET0241.

Dimension:

- width 59 cm

- height 133 cm

- depth 34 cm

Type of tube	Length [mm]	Quantity [pcs]
RCH1 1,6 / 0,8	1 000	30
RCH1 2,4 / 1,2	1 000	40
RCH1 3,2 / 1,6	1 000	70
RCH1 4 / 1	1 000	40
RCH1 4,8 / 2,4	1 000	70
RCH1 6,4 / 3,2	1 000	60
RCH1 8 / 2	1 000	45
RCH1 9,5 / 4,8	1 000	40
RCH1 12,7 / 6,4	1 000	30
RCH1 19 / 9,5	1 000	15
RCH1 25,4 / 12,7	1 000	15
RCH1 38 / 19	1 000	5
RCKH1 4 / 1	500	10
RCKH1 6 / 2	500	10
RCKH1 8 / 2	500	10
RCKH1 12 / 3	500	10

Stand with medium wall, heat-resistants adhesive-layered tubes - type RPKH1-1

Comfortable exposition cardboard contains a set of medium wall heat shrink tubes adhesive-layered in black colour.

The stand is made of moisture-proof polypropylene material.

Shrink temperature heat-shrinkable tubing from +90 up to + 200°C.

Easier product identification.

Printed size on all tubes.

Quick and easy installation.

A big shrink strength.

Possibility of insulation and cable coating reconstruction.

Protection against moisture.

High resistance to changing weather conditions, UV radiation.

Index: WET0211.

Type of tube	Length [mm]	Quantity [pcs]
RPKH1 9/3	1000	5
RPKH1 12/4	1000	13
RPKH1 17/3	1000	4
RPKH1 18/6	1000	5
RPKH1 22/6	1000	5
RPKH1 25/10	1000	10
RPKH1 30/8	1000	4
RPKH1 35/12	1000	5
RPKH1 40/16	1000	5
RPKH1 52/20	1000	4
RPKH1 63/19	1000	4



Easier product identification.
Overprint with size on every tube.



Dimension:
- width 59 cm
- height 133 cm
- depth 34 cm

Display stand with heat shrinkable accessories - type EOT1

Display stand EOT1 contains the most popular cable joints ZRM 0.6 / 1kV for 4-core cables type Y (A) KY, Y (A) KXS, as well as breakout-boots AK4 for 4-core cables, heat shrink end-caps REC and insulation tapes black and colored; that is, all the necessary elements in the work of an installer!

Index: WET022.

Item set	Quantity [pcs]
ZRM 1,5-10	15 kpl
AR 19/20-C	10 kpl
AR 19/20-RM	10 kpl
AK4 6-35	10 szt.
AK4 25-95	10 szt.
AK4 35-150	10 szt.
AK4 95-300	5 szt.
REC 50	10 szt.
REC 75	10 szt.
REC 110	5 szt.
ZRM-1/JLP-CX4 16-25/700	10 kpl
ZRM-2/JLP-CX4 35-70/700	15 kpl
ZRM-3/JLP-CX4 95/700	5 kpl
ZRM-4/JLP-CX4 120-150/900	5 kpl
ZRM-5/JLP-CX4 185-300/900	5 kpl



Dimension:
- width 100 cm
- height 195 cm
- depth 45 cm

Medium wall heat shrink heat-resistant tubes +125°C - type RPH1, RPKH1, RPH1S, RPKH1S

Application

Used to restore the insulation and the outer cable coating, high shrink ratio and a wall thickness guarantee excellent insulating properties, and provide a close fit to a wide variety of irregular shapes.

The applied hot-melt adhesive provides an additional moisture barrier needed in the construction cable joints and terminations.

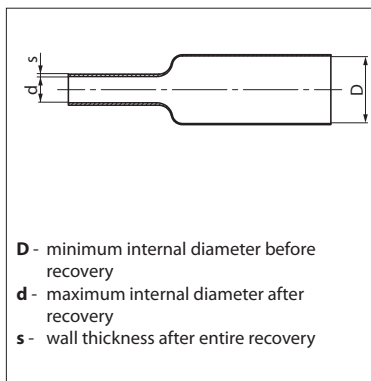

Operating temperature: RPH1 -55 up to +125°C*, RPKH1 -25 up to +125°C*, RPH1S -40 up to +125°C*, RPKH1S -40 up to +125°C* *outer layer

Tubes halogen-free: RPH1, RPKH1

Tubes self-extinguishing: RPH1S, RPKH1S

Shrink ratio: 3:1, 4:1

The minimum shrink temperature: +120°C

Colours: black

UV resistant

In accordance with REACH, RoHS

Tube type	Index (black color)	Tube type	Index (black color)	Dimensions [mm]			Packing [pcs. 1 m]
				D	d	s	
RPH1 9 / 3	WRJPC9000300010030C1	RPKH1 9 / 3	WRDPC900030001003KC1	9	3	2,0	50
RPH1 12 / 4	WRJPC1200400010030C1	RPKH1 12 / 4	WRDPC120040001003KC1	12	4	2,0	50
RPH1 18 / 6	WRJPC1800600010030C1	RPKH1 17 / 3	WRDPC170030001003KC1	17	3	2,5	50
RPH1 22 / 6	WRJPC2200600010030C1	RPKH1 18 / 6	WRDPC180160001003KC1	18	6	2,0	50
RPH1 25 / 10	WRJPC2500100010030C1	RPKH1 22 / 6	WRDPC220060001003KC1	22	6	2,0	50
RPH1 35 / 12	WRJPC3500120010030C1	RPKH1 25 / 10	WRDPC250110001003KC1	25	10	2,0	50
RPH1 40 / 16	WRJPC4000160010030C1	RPKH1 30 / 8	WRDPC300080001003KC1	30	8	2,0	30
RPH1 52 / 20	WRJPC5200200010030C1	RPKH1 35 / 12	WRDPC350012001003KC1	35	12	2,0	30
RPH1 63 / 19	WRJPC6300190010030C1	RPKH1 40 / 16	WRDPC400016001003KC1	40	16	2,0	50
RPH1 80 / 35	WRJPC8000350010030C1	RPKH1 52 / 20	WRDPC520020001003KC1	52	20	2,5	40
RPH1 103 / 45	WRJPC1030450010030C1	RPKH1 63 / 19	WRDPC630019001003KC1	63	19	2,5	30
RPH1 132 / 58	WRJPC1320580010030C1	RPKH1 80 / 35	WRDPC800035001003KC1	80	35	4,0	20
		RPKH1 103 / 45	WRDPC103045001003KC1	103	45	4,5	15
		RPKH1 132 / 58	WRDPC132058001003KC1	132	58	4,5	10

Standard length = 1 m, longer RPH1, RPKH1 tubes available on special request.

Tube type	Index (black color)	Tube type	Index (black color)	Dimensions [mm]			Packing [pcs. 1 m]
				D	d	s	
RPH1S 9 / 3	WRJPE9000300010030C1	RPKH1S 9 / 3	WRDPE900030001003KC1	9	3	2,0	50
RPH1S 12 / 4	WRJPE1200400010030C1	RPKH1S 12 / 4	WRDPE120040001003KC1	12	4	2,0	50
RPH1S 22 / 6	WRJPE2200600010030C1	RPKH1S 22 / 6	WRDPE220060001003KC1	22	6	2,0	50
RPH1S 25 / 10	WRJPE2500100010030C1	RPKH1S 25 / 10	WRDPE250010001003KC1	25	10	2,0	50
RPH1S 30 / 8	WRJPE3000800010030C1	RPKH1S 30 / 8	WRDPE300080001003KC1	30	8	2,5	30
RPH1S 35 / 12	WRJPE3500120010030C1	RPKH1S 35 / 12	WRDPE350010001003KC1	35	12	2,0	30
RPH1S 40 / 16	WRJPE4000160010030C1	RPKH1S 40 / 16	WRDPE400016001003KC1	40	16	2,0	50
RPH1S 52 / 20	WRJPE5200200010030C1	RPKH1S 52 / 20	WRDPE520020001003KC1	52	20	2,5	40
RPH1S 63 / 19	WRJPE6300190010030C1	RPKH1S 63 / 19	WRDPE630019001003KC1	63	19	2,5	30
RPH1S 80 / 35	WRJPE8000350010030C1	RPKH1S 80 / 35	WRDPE800035001003KC1	80	35	4,0	20
RPH1S 103 / 45	WRJPE1030450010030C1	RPKH1S 103 / 45	WRDPE103045001003KC1	103	45	4,5	15
RPH1S 132 / 58	WRJPE1320580010030C1	RPKH1S 132 / 58	WRDPE132058001003KC1	132	58	4,5	10

Standard length = 1 m, longer RPH1S, RPKH1S tubes available on special request.

Properties	Test method	Tubes RPH1 RPKH1	Tubes RPH1S RPKH1S
Operating temperature		-55 up to +125°C* -25 up to +125°C*	-40 up to +125°C -40 up to +125°C* *outer layer
Length change after shrinking	EN 60684-2	+5 ÷ -10%	+5 ÷ -10%
Tensile strength, min.	EN 60684-2	14 MPa	9 MPa
Elongation at rupture, min.	EN 60684-2	350%	200%
Heat ageing 168 hours	EN 60684-2	158°C	158°C
Tensile strength after heat ageing, min.	EN 60684-2	12 MPa	7 MPa
Elongation at rupture after heat ageing, min.	EN 60684-2	250%	150%
Heat shock (4 hours, temperature)	EN 60684-2	200°C no dripping, breaking and wall spreading	
Contact with Cu after heat ageing (168 hours, temperature): elongation at rupture, min.	EN 60684-2	158°C 100%	158°C 100%
Cu corrosion	EN 60684-2	nie koroduje	
Cold bend; 4 hours	EN 60684-2	doesn't break in temp. -55°C	doesn't break in temp. -40°C
Flammability	EN 60684-2	firearms	self-extinguishing
Water absorptivity, max	ISO 62	0,1%	0,5%
Dielectric resistance, min.	EN 60684-2; IEC 60243-1	16kV/mm	15kV/mm
Volume resistivity, min.	EN 60684-2; IEC 60093	10 ¹² Ωm	10 ¹¹ Ωm

Examples of applications of heat shrink tubes.

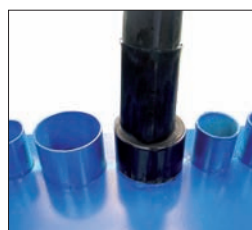

Medium wall heat shrink tubes with mastic - type RPM

Application RPM tubes are on all length covered with mastic sealing. They are designed for the protection of metal pipes' joints and other connections which require reliable sealing. Radiation crosslinked covering guarantee effective mechanical protection. Mastic layer guard against moist and water penetration.

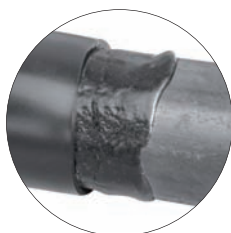
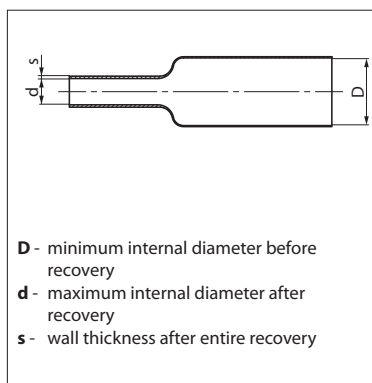

Operating temperature:
Shrink ratio:
The minimum shrink temperature:
Standard color:
UV resistant
Covered on all length with mastic sealing
Good insulation properties

from -35 up to +110°C (IEC 216)
3:1
+120°C
black

Tube type	Indekx	Dimensions [mm]			Packing [pcs. 1 m]
		D	d	s	
RPM 30/6	TRJHA300160001003MC1	30	6	2,5	10
RPM 33/8	TRJHA330180001003MC1	33	8	2,5	10
RPM 40/12	TRJHA400112011003MC1	40	12	2,5	10
RPM 55/20	TRJHA550120011003MC1	55	20	2,0	10
RPM 75/25	TRJHA750125011003MC1	75	25	2,0	10
RPM 95/30	TRJHA950130011003MC1	95	30	2,0	10
RPM 120/40	TRJHA120240011003MC1	120	40	2,0	1
RPM 140/50	TRJHA140250011003MC1	140	50	2,3	1
RPM 160/50	TRJHA160250011003MC1	160	50	2,3	1
RPM 180/66	TRJHA180266011003MC1	180	66	2,5	1
RPM 205/66	TRJHA205266011003MC1	205	66	2,5	1
RPM 235/70	TRJHA235270001003MC1	235	70	2,5	1
RPM 265/75	TRJHA265275011003MC1	265	75	3,0	1
RPM 300/85	TRJHA300285011003MC1	300	85	3,0	1
RPM 350/100	TRJHA350210021003MC1	350	100	3,0	1

Properties	Test method	Tubes RPM
Tensile strength	ASTM D 2671	≥ 14 MPa
Elongation at rupture	ASTM D 2671	≥ 400%
Longitudinal change after recovery	UL 224	0-10%
Elongation at rupture after heat ageing, min.	+150°C, 168h	≥ 300%
Dielectric strength	IEC 243	≥ 20kV/mm
Volume resistivity	IEC 93	≥ 10 ¹⁴ Ωcm
Influence on copper	ASTM D 2671	doesn't corrode
Stress cracking resistance (+50°C)	ASTM D 1693	doesn't break
Cold bend (-55°C, 4h)	ASTM D 2671	doesn't break
Properties of mastic		
Water absorption	ISO 62	< 0,1%
Softening point	ASTM D E8	80°C
Peel strength	ASTM D 1000	50N/25 mm
Influence on copper	ASTM D 2671	doesn't corrode
Fungus resistance	ISO 846	resistant

Heat shrink tubes of large diameters - type RDK, RDM, RD

Application

They are designed for insulation of metal elements, lampposts, masts, pipelines and elements of bridges.

Due to high shrink ratio, they are a great insulation for cable culverts ends e.g. under the streets.

RDK tubes are wholly adhesive-layered and RDM are supplied with mastic stripes at the ends.

Both adhesive layer and mastic stripes are tight insulation and protect against any moist penetration under the heat shrink layer.

The dimensions of RDK and RDM tubes are specially matched to the sizes of lampposts. They protect them effectively against salt, animals' urine and gases in the air.

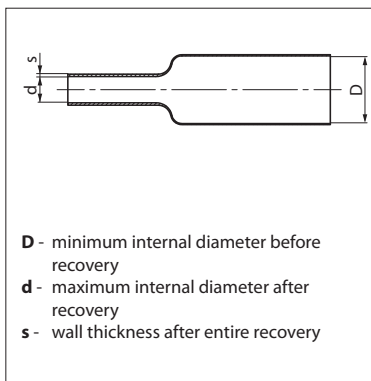

Operating temperature:	RDK -15 up to +125°C*, RDM -40 up to +125°C*, RD -55 up to +125°C *outer layer
Tubes with adhesive:	RDK
Tubes with with mastic:	RDM
Tubes without adhesive and mastic:	RD
Shrink ratio:	2:1, 4:1
The minimum shrink temperature:	+120°C
Colours:	black
Tubes halogen-free	
UV resistant	
In accordance with REACH, RoHS	

Tube type	Tube with adhesive Index	Tube type	Tube with mastic Index	Dimensions [mm]			Packing [pcs. 1 m]
				D	d	s	
RDK 55 / 15	WRDDA550115011003KC1			55	15	4,5	40
RDK 76 / 18	WRDDA760118011003KC1	RDM 76 / 18	WRJDA760118011003MC1	76	18	4,0	15
RDK 95 / 25	WRDDA950125011003KC1	RDM 95 / 25	WRJDA950125011003MC1	95	25	4,5	12
RDK 105 / 32	WRDDA105232011003KC1	RDM 105 / 32	WRJDA105232011003MC1	105	32	4,0	12
RDK 140 / 34	WRDDA140234011003KC1	RDM 140 / 34	WRJDA140234011003MC1	140	34	4,5	8
RDK 155 / 90	WRDDA155290011003KC1	RDM 155 / 90	WRJDA155290011003MC1	155	90	2,9	1
RDK 175 / 90	WRJDA175290011003KC1	RDM 175 / 90	WRJDA175290011003MC1	175	90	2,9	1
RDK 195 / 90	WRJDA195290011003KC1	RDM 195 / 90	WRJDA195290011003MC1	195	90	2,5	1
RDK 225 / 90	WRJDA225290011003KC1	RDM 225 / 90	WRJDA225290011003MC1	225	90	2,5	1
RDK 245 / 125	WRJDA245212521003KC1	RDM 245 / 125	WRJDA245212521003MC1	245	125	2,8	1
RDK 255 / 125	WRJDA255212521003KC1	RDM 255 / 125	WRJDA255212521003MC1	255	125	2,8	1
RDK 275 / 125	WRJDA275212521003KC1	RDM 275 / 125	WRJDA275212521003MC1	275	125	2,8	1
RDK 300 / 125	WRJDA300212521003KC1	RDM 300 / 125	WRJDA300212521003MC1	300	125	2,8	1
RDK 350 / 125	WRJDA350212521003KC1	RDM 350 / 125	WRJDA350212521003MC1	350	125	2,8	1
RDK 390 / 200	WRJDA390220021003KC1	RDM 390 / 200	WRJDA390220021003MC1	390	200	3,0	1
RDK 400 / 200	WRJDA400220021003KC1	RDM 400 / 200	WRJDA400220021003MC1	400	200	3,0	1
RDK 440 / 200	WRJDA440220021003KC1	RDM 440 / 200	WRJDA440220021003MC1	440	200	3,0	1
RDK 460 / 200	WRJDA460220021003KC1	RDM 460 / 200	WRJDA460220021003MC1	460	200	3,0	1
RDK 500 / 200	WRJDA500220021003KC1	RDM 500 / 200	WRJDA500220021003MC1	500	200	3,0	1
RDK 530 / 200	WRJDA530220021003KC1	RDM 530 / 200	WRJDA530220021003MC1	530	200	3,0	1
RDK 560 / 250	WRJDA560225021003KC1	RDM 560 / 250	WRJDA560225021003MC1	560	250	3,2	1
RDK 620 / 250	WRJDA620225021003KC1	RDM 620 / 250	WRJDA620225021003MC1	620	250	3,2	1
RDK 710 / 250	WRJDA710225021003KC1	RDM 710 / 250	WRJDA710225021003MC1	710	250	3,2	1

Tube without adhesive and mastic		Dimensions [mm]			Packing
Tube type	Index	D	d	s	[pcs. 1 m]
RD 55 / 15	WRJDA5501150110030C1	55	15	4,5	40
RD 76 / 18	WRJDA7601180110030C1	76	18	4,0	15
RD 95 / 25	WRJDA9501250110030C1	95	25	4,5	15
RD 105 / 32	WRJDA1052320110030C1	105	32	4,0	12
RD 140 / 34	WRJDA1402340110030C1	140	34	4,5	8
RD 155 / 90	WRJDA1552900110030C1	155	90	2,9	1
RD 175 / 90	WRJDA1750900010030C1	175	90	2,9	1
RD 195 / 90	WRJDA1952900110030C1	195	90	2,5	1
RD 225 / 90	WRJDA2252900110030C1	225	90	2,5	1
RD 245 / 125	WRJDA2452125210030C1	245	125	2,8	1
RD 255 / 125	WRJDA2552125210030C1	255	125	2,8	1
RD 275 / 125	WRJDA2752125210030C1	275	125	2,8	1
RD 300 / 125	WRJDA3002125210030C1	300	125	2,8	1
RD 350 / 125	WRJDA3502125210030C1	350	125	2,8	1
RD 390 / 200	WRJDA3902200210030C1	390	200	3,0	1
RD 400 / 200	WRJDA4002200210030C1	400	200	3,0	1
RD 440 / 200	WRJDA4402200210030C1	440	200	3,0	1
RD 460 / 200	WRJDA4602200210030C1	460	200	3,0	1
RD 500 / 200	WRJDA5002200210030C1	500	200	3,0	1
RD 530 / 200	WRJDA5302200210030C1	530	200	3,0	1
RD 560 / 250	WRJDA5602250210030C1	560	250	3,2	1
RD 620 / 250	WRJDA6202250210030C1	620	250	3,2	1
RD 710 / 250	WRJDA7102250210030C1	710	250	3,2	1

Standard length 1 m. Up to the dimension 140/34 lengths > 1 m are possible.
On special demand we can produce tubes of non standard sizes.

Properties	Test method	Tubes RDK / RDM / RD
Operating temperature		-15 up to +125°C / -40 up to +125°C / -55 up to +125°C *outer layer
Length change after shrinking	EN 60684-2	+5 ÷ -15%
Tensile strength, min	EN 60684-2	12 MPa
Elongation at rupture, min.	EN 60684-2	300%
Heat ageing (168 h, temperature)	EN 60684-2	158°C
Tensile strength after heat ageing, min.	EN 60684-2	10 MPa
Elongation at rupture after heat ageing, min.	EN 60684-2	200%
Heat shock (4 hours, temperature)	EN 60684-2	200°C no dripping, breaking and wall spreadi
Contact with Cu after heat ageing (168 hours, temperature): elongation at rupture, min.	EN 60684-2	158°C 100%
Cu corrosion	EN 60684-2	doesn't corrodee
Cold bend; 4 hours	EN 60684-2	doesn't break in temp. -55°C
Flammability	EN 60684-2	firearms
Water absorptivity, max	ISO 62	0,1%
Dielectric resistance, min.	EN 60684-2; IEC 60243-1	16kV/mm
Volume resistivity, min.	EN 60684-2; IEC 60093	10 ¹² Ωm

Examples of applications of heat shrink tubes



Thick wall heat shrink tubes, adhesive-layered, high shrink ratio 6:1 - type RBG

Application

Ideal insulation on objects with different diameters - cables, connectors and other elements.

High shrink strength guarantees good adherence to the objects of various shapes.

They make a good mechanical protection of cable joints and terminations.

Full protection against environmental influence.

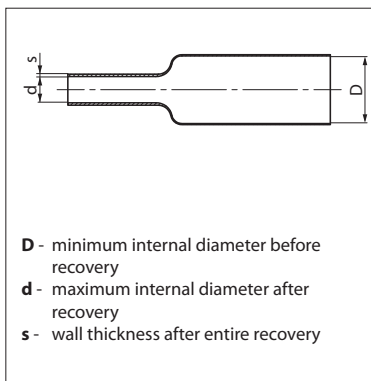

D - minimum internal diameter before recovery
d - maximum internal diameter after recovery
s - wall thickness after entire recovery



Operating temperature: -55 up to +110°C (IEC 216)

Shrink ratio: 6:1

The minimum shrink temperature: +120°C

Colours: black

UV resistant

Very high mechanical protection

Tube type	Index	Dimensions [mm]			Packing [pcs. 1 m]	Cut into [m]
		D	d	s		
RBG 19,0 / 3,2	TRDHA190132001223KC1	19,0	3,2	3,2	20	1,22
RBG 33,0 / 5,5	TRDHA330155001223KC1	33,0	5,5	3,4	20	1,22
RBG 44,4 / 7,4	TRDHA444174001223KC1	44,4	7,4	3,6	20	1,22
RBG 50,8 / 8,3	TRDHA508183001223KC1	50,8	8,3	4,3	20	1,22
RBG 69,8 / 11,7	TRDHA698111711223KC1	69,8	11,7	4,8	20	1,22
RBG 88,9 / 17,1	TRDHA889117111223KC1	88,9	17,1	4,8	20	1,22
RBG 119,4 / 22,9	TRDHA119222911223KC1	119,4	22,9	4,8	10	1,22
RBG 235 / 40	TRDHA235240011003KC1	235,0	40,0	4,8	1	1,22

Properties	Test method	Tubs RBG
Tensile strength	ASTM D 2671	> 14 MPa
Elongation at rupture	ASTM D 2671	> 400%
Density	ASTM D 792	1,05 g/cm ³
Longitudinal change after recovery	UL 224	0 - 10%
Elongation at rupture after heat ageing, min.	+150°C, 168 ч	> 300%
Dielectric strength	IEC 243	> 20kV/mm
Volume resistivity	IEC 93	> 10 ¹⁴ Ωm
Influence on copper	ASTM D 2671	doesn't corrode
Stress cracking resistance (+50°C)	ASTM D 1 693	doesn't break
Properties of adhesive		
Water absorption	ISO 62	< 0,2%
Softening point	ASTM D E8	85°C
Peel strength	DIN 30672	4 N/cm
Influence on copper	ASTM D 2671	doesn't corrode
Fungus resistance	ISO 846	resistant

Medium wall heat shrink tubes, insulation, for Medium Voltage up to 36kV, anti-tracking - type RPAT

Application

Designed for insulation in cable terminations and joints for Medium Voltage up to 36kV.

Their anti-tracking properties guarantee maximum reliability when installed.

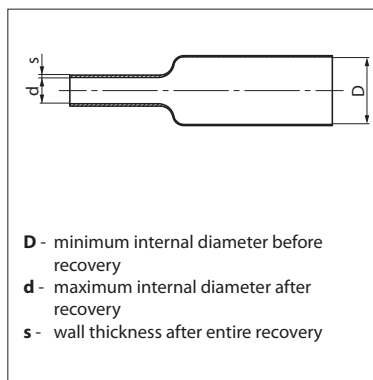

D - minimum internal diameter before recovery
d - maximum internal diameter after recovery
s - wall thickness after entire recovery



Operating temperature: -55 up to +125°C
 The minimum shrink temperature: +110°C
 Standard color: red
 Halogen-free
 UV resistant
 Produced from special formula of radiation crosslinked polyethylene

Tube type	Index	Dimensions [mm]			Standard length of spool [m]
		D	d	s	
RPAT 19 / 6	TRJHQ1901600030040D1	19	6	2,5	30
RPAT 30 / 10	TRJHQ3001100115040D1	30	10	3,0	15
RPAT 35 / 12	TRJHQ3501120115040D1	35	12	3,0	15
RPAT 40 / 16	TRJHQ4001160115040D1	40	16	3,0	15
RPAT 45 / 18	TRJHQ4501180115040D1	45	18	3,0	15
RPAT 54 / 24	TRJHQ5401240115040D1	54	24	3,0	15
RPAT 60 / 29	TRJHQ6001290115040D1	60	29	3,0	15
RPAT 76 / 38	TRJHQ7601380115040D1	76	38	3,0	15
RPAT 100 / 49	TRJHQ1002490115040D1	100	49	3,0	15
RPAT 130 / 50	TRJHQ1302500100000D1	130	50	4,0	cut into 1 [m] lengths

Properties	Test method	Tubs RPAT
Tensile strength	ASTM D 2671	minimum 11 MPa
Elongation at rupture	ASTM D 2671	minimum %
Longitudinal change after recovery	ASTM D 2671	0 - 10%
Tensile strength after ageing (+120°C, 168 h)	ASTM D 2671	minimum 13 MPa
Elongation at rupture after ageing (+120°C, 168 h)	ASTM D 2671	minimum 350%
Dielectric strength	IEC 243	minimum 19kV/mm
Anti-tracking test	ASTM D 2303	3,75kV, 1 h, brak
Dielectric constant	IEC 250	maximum 3,0
Volume resistivity	ASTM D 2303	minimum 10 ¹³ Ωcm
Flammability (oxygen index)	IEC 93	minimum 25
Influence on copper (+120°C, 168 h)	ASTM D 2671	doesn't corrode
Cold bend (-40°C, 4 h)	ASTM D 2671	doesn't break

Medium and thick wall heat shrink tubes for Medium Voltage bus bar insulation - type RBM i RBH

Application

Designed for better insulation of bus bars in switchgears and substations. They guarantee high anti-tracking protection and arcing resistance. The form of tube makes the installation of it more comfortable and cheaper.

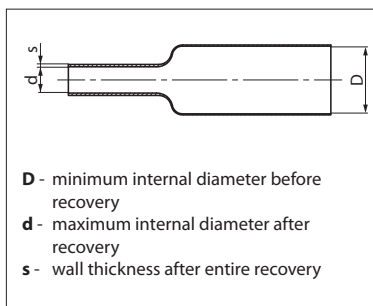

Operating temperature: -40 up to +125°C
The minimum shrink temperature: +110°C
Standard color: red
Halogen-free
Produced from modified radiation crosslinked polyethylene

Tube type	Index	Dimensions [mm]			Recommended bus bar size [mm]	Standard length of spool [m]
		D	d	s		
RBM 25 / 10	TRJHP2501100130040D1	25	10	2,0	25 x 3	30
RBM 30 / 12	TRJHP3001120130040D1	30	12	2,0	35 x 4	30
RBM 35 / 14	TRJHP3501140130040D1	35	14	2,0	35 x 4	30
RBM 40 / 16	TRJHP4001160130040D1	40	16	2,0	40 x 5	30
RBM 50 / 20	TRJHP5001200115040D1	50	20	2,0	50 x 5	15
RBM 65 / 25	TRJHP6501250115040D1	65	25	2,0	65 x 8	15
RBM 75 / 30	TRJHP7501300115040D1	75	30	2,0	75 x 8	15
RBM 100 / 40	TRJHP1002400115040D1	100	40	2,0	100 x 10	15

Tube type	Index	Dimensions [mm]			Recommended bus bar size [mm]	Standard length of spool [m]
		D	d	s		
RBH 19 / 6	TRJHO1901600115040D1	19	6	3,0	15 x 3	15
RBH 25 / 10	TRJHO2501100115040D1	25	10	3,0	25 x 3	15
RBH 30 / 12	TRJHO3001120115040D1	30	12	3,0	35 x 4	15
RBH 40 / 16	TRJHO4001160115040D1	40	16	3,0	40 x 5	15
RBH 50 / 20	TRJHO5001200115040D1	50	20	3,0	50 x 5	15
RBH 65 / 25	TRJHO6501250115040D1	65	25	3,0	65 x 8	15
RBH 75 / 30	TRJHO7501300115040D1	75	30	3,0	75 x 8	15
RBH 85 / 35	TRJHO8501350115040D1	85	35	3,0	85 x 10	15
RBH 100 / 40	TRJHO1002400115040D1	100	40	3,0	100 x 10	15
RBH 120 / 50	TRJHO1202500115040D1	120	50	3,0	120 x 12	15
RBH 150 / 60	TRJHO1502600100000D1	150	60	3,0	150 x 15	cut into 1 [m] lengths

Rated voltage	Minimal distances without insulation [mm]	Phase to Phase [mm]		Phase to Ground [mm]	
		RBM	RBH	RBM	RBH
12kV	120	65	35	75	45
17,5kV	160	85	55	105	65
24kV	220	115	70	150	100
36kV	320	200	140	285	190

Properties	Test method	Tubes RBM / RBH
Tensile strength	ASTM D 2671	minimum 11,8 MPa
Tensile strength after ageing (+120°C, 168 h)	ASTM D 2671	minimum 10 MPa
Longitudinal change after recovery	ASTM D 2671	0 - 10%
Elongation at rupture	ASTM D 2671	700%
Elongation at rupture after ageing (+120°C, 168 h)	ASTM D 267 1	minimum 500%
Dielectric strength	IEC 243	minimum 20kV/mm
Dielectric constant	IEC 250	maksimum 3,0
Volume resistivity	IEC 93	minimum 10 ¹³ Ωcm
Flammability (oxygen index)	ASTM 4589	minimum 25
Influence on coppe (+120°C, 168 h)	ASTM D 2671	doesn't corrode
Cold bend (-40°C, 4 h)	ASTM D 2671	doesn't break
Water absorption (+23°C, 14 day)	ISO 62	minimum 0,5%

Insulating tapes for bus bars - typu RTBB

Application They are very flexible and easy to install. They are designed for bus bar insulation in all the places the tube could not be installed.
Guarantee a good electrical and percussive insulation of bus bars up to 24kV.
Easy to remove for review or maintenance.



Operating temperature: -55 up to +105°C
The minimum shrink temperature: +110°C
Standard color: red
UV resistant
Produced from radiation crosslinked polyethylene

Tube type	Index	Wymiary [mm]		Packing [pcs]	Standard length [m]
		Width	Thickness after recovery		
RTBB-1	TTHS0025051	25	1,00 + 0,10	1	5
RTBB-2	TTHS0050051	50	1,00 + 0,15	1	5

Properties	Test method	Tubs RTBB
Tensile strength	ASTM D 638	minimum 13 MPa
Tensile strength after ageing (+120°C, 168 h)	ASTM D 2671	minimum 10 MPa
Longitudinal change after recovery	ASTM D 638	550%
Elongation at rupture after ageing (+120°C, 168 h)	ASTM D 2671	minimum 450%
Dielectric strength	IEC 243	minimum 20kV/mm
Dielectric constant	IEC 250	maximum 3,0
Volume resistivity	IEC 93	minimum 10 ¹³ Ωcm
Flammability	ASTM D 2671	self-extinguishing after 60 s
Influence on copper (+120°C, 168 h)	ASTM D 2671	doesn't corrode
Water absorption (+23°C, 14 dni)	ISO 62	minimum 0,5%
Shrink ratio		30%

Heat shrink tubes of modified fluoroelastomer, very flexible - type RFE

Application

They are recommended for installation where a high resistance to corrosive liquids - oils, lubricants, solvents - in higher temperatures occurs.

The tubes guarantee high abrasion-resistance, unchangeable flexibility in low and high temperatures. No cracks.

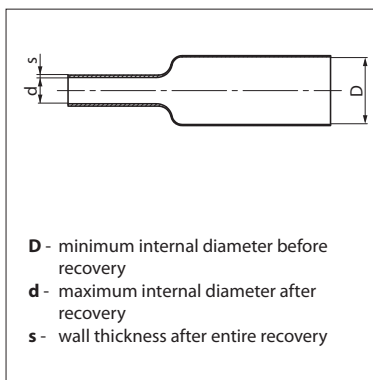

Operating temperature: -55 up to +200°C (IEC 216)

The minimum shrink temperature: +150°C

Standard color: black

Self-extinguishing

Produced from modified fluoroelastomer radiation crosslinked

Tube type	Index	Dimensions [mm]			Standard length of spool [m]
		D	d	s	
RFE 3,2 / 1,6	TRJHR3200160010050C1	3,2	1,6	0,76	50
RFE 4,8 / 2,4	TRJHR4800240050040C1	4,8	2,4	0,90	50
RFE 6,4 / 3,2	TRJHR6400320010050C1	6,4	3,2	0,90	50
RFE 9,5 / 4,8	TRJHR9500480050040C1	9,5	4,8	0,90	50
RFE 12,7 / 6,4	TRJHR1271640030040C1	12,7	6,4	1,10	30
RFE 19,1 / 9,5	TRJHR1911950030040C1	19,1	9,5	1,30	30
RFE 25,4 / 12,7	TRJHR2541127115040C1	25,4	12,7	1,65	30
RFE 38,1 / 19,1	TRJHR3811191115040C1	38,1	19,1	1,90	15

Properties	Test method	Tubs RFE
Tensile strength	ASTM D 2671	minimum 8,5 MPa
Tensile strength after ageing	+250°C, 168 h	minimum 200%
Heat shock	+300°C, 4 h	no cracks
Secant modulus	ASTM D 412	maximum 13,8 MPa
Dielectric strength	ASTM D 2671	minimum 7,9kV/mm
Volume resistivity	ASTM D 876	10 ¹⁴ Ωcm
Influence on copper (+175°C, 16 h)	SAE-AMS-DTL-23053/13	doesn't corrode
Flammability	ASTM D 2671	self-extinguishing after 15 s

Teflon heat shrink tubes - type RTE

Application

Designed for application in places where a good resistant to high temperatures and chemicals is required.

They are meant for military, motorization, aviation and others due to their good electrical insulation and high heat-resistance.

They provide total protection against environmental influences.

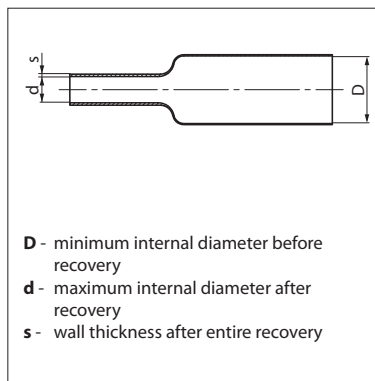

Operating temperature: -65 up to +260°C
 The minimum shrink temperature: +350°C
 Standard color: transparent

Tube type	Index	Dimensions [mm]			Packing [pcs]	Cut into [m]
		D	d	s		
RTE 1,52 / 0,97	TRJHV152009701223001	1,52	0,97	0,3	10	1,22
RTE 1,93 / 1,17	TRJHV193011701223001	1,93	1,17	0,3	10	1,22
RTE 2,36 / 1,45	TRJHV236014501223001	2,36	1,45	0,30	10	1,22
RTE 3,05 / 1,82	TRJHV305018201223001	3,05	1,82	0,30	10	1,22
RTE 3,81 / 2,26	TRJHV381022601223001	3,81	2,26	0,30	10	1,22
RTE 4,85 / 2,80	TRJHV485028001223001	4,85	2,80	0,30	10	1,22
RTE 6,10 / 3,55	TRJHV610035501223001	6,10	3,55	0,38	10	1,22
RTE 7,67 / 4,40	TRJHV767044001223001	7,67	4,40	0,38	10	1,22
RTE 9,40 / 5,45	TRJHV940054501223001	9,40	5,45	0,38	10	1,22
RTE 10,92 / 6,90	TRJHV109169001223001	10,92	6,90	0,38	10	1,22
RTE 11,94 / 8,56	TRJHV119185601223001	11,94	8,56	0,38	10	1,22

Properties	Test method	Tubs RTE
Tensile strength	ASTM D 2671	17 MPa
Tensile strength after ageing	ASTM D 2671	200%
Specific gravity	ASTM D 792	2,3
Heat shock (+400°C, 4 h)	ASTM D 2671	no cracks
Cold bend (-65°C, 4 h)	ASTM D 2671	no cracks
Volume resistivity	ASTM D 2671	10 ¹⁸ Ωcm
Dielectric strength	ASTM D 2671	34kV/mm
Influence on copper	UL 224	doesn't corrode
Flammability	ASTM D 2671	self-extinguishing
Chemical resistance	SAE-AMS-DTL-23053/12	perfect
Water absorption	ASTM D 570	maximum 0,1%

Heat shrink breakout boots

Heat shrink breakout boots: 2-core, 3-core, 4-core and 5-core - type AK

Properties

Heat shrink breakout boots AK are designed for insulation of cable ends at separated cores.

They are elements for both indoor and outdoor terminations and cable joints of polymer or paper insulated cables. Voltage: 0,6/1kV and 3,5/6kV

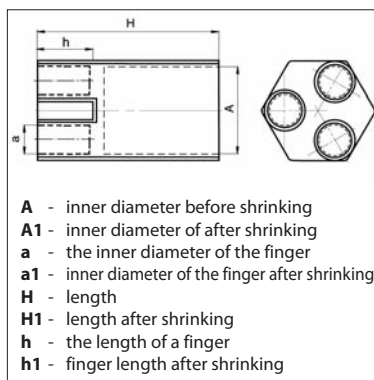

Product name	Index	Number of cores	Dimensions [mm]								Wall thickness	Core thickness	Cumulative packing [sets]
			A	A1	a	a1	H	H1	h	h1			
AK2 1,5-25	TKP2K030101204C1	2	30,0	10,0	12,0	4,0	70,0	95,0	18,0	28,0	2,0	2,0	10
AK2 25-120	TKP2K050242107C1	2	50,0	24,0	21,0	7,0	85,0	120,0	29,0	40,0	3,0	3,0	10
AK2 120-240	TKP2K098422808C1	2	98,0	42,6	28,4	8,2	147,4	165,3	65,8	68,8	3,3	3,3	5
AK3 1,5-16	TKP3K025090903C1	3	25,0	9,0	9,0	3,0	45,0	76,0	14,0	20,0	2,5	1,2	10
AK3 4-35	TKP3K035151304C1	3	35,0	11,6	13,0	3,5	85,0	117,0	18,0	31,0	2,2	1,4	10
AK3 25-120	TKP3K050212209C1	3	50,0	21,1	22,0	9,0	165,4	164,3	31,0	50,0	3,5	2,2	10
AK3 95-300	TKP3K075313214C1	3	75,0	31,0	32,0	14,0	190,0	220,0	55,0	60,0	3,5	2,7	5
AK4 1,5-10	TKP4K028090802C1	4	28,0	9,0	8,0	2,0	50,0	78,0	16,0	21,0	2,7	2,7	10
AK4 6-35	TKP4K035161205C1	4	35,0	16,0	12,0	5,0	85,0	105,0	14,0	20,0	2,3	1,4	10
AK4 25-95	TKP4K055202006C1	4	55,0	20,0	20,0	6,0	140,0	150,0	30,0	38,0	3,0	2,5	10
AK4 35-150	TKP4K060262210C1	4	60,0	26,0	22,0	10,0	154,5	187,4	38,4	51,5	5,6	2,5	10
AK4 95-300	TKP4K090353414C1	4	90,0	35,0	34,0	14,0	170,0	218,0	51,0	58,0	4,0	2,8	5
AK4 240-400	TKP4K135515114C1	4	135,0	50,6	51,5	13,9	213,2	241,8	68,0	78,7	4,2	4,2	1
AKF1	TKP4K162706418C1	4	162,0	70,0	64,0	18,0	240,0	260,0	75,0	80,0	4,2	4,2	1
AK5 1,5-16	TKP5K032071103C1	5	31,5	6,1	11,2	2,7	50,0	60,0	20,0	28,0	1,5	1,8	10
AK5 10-70	TKP5K058151604C1	5	57,0	14,7	15,8	2,9	83,0	112,0	20,5	30,5	2,0	1,9	10
AK5 70-120	TKP5K058151604C1	5	81,3	31,7	24,6	5,7	153,0	180,0	57,8	63,1	3,9	3,0	10
AK5 150-240	TKP5K102423308C1	5	102,0	41,8	33,6	7,7	162,9	196,7	64,5	71,3	4,1	3,2	5

3-core heat shrink breakout boots for MV up to 36kV - type AKR

Application

Heat shrink breakout boots AKR are designed for insulation of MV cable ends at separated cores.

They are the integral part of MV indoor and outdoor cable terminations.

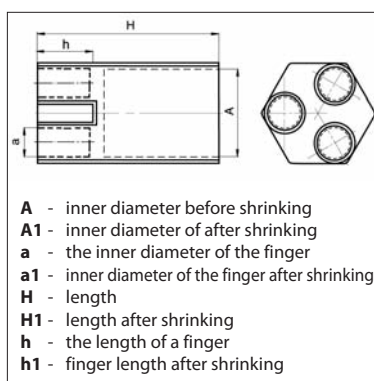

Product name	Index	Number of cores	Dimensions [mm]								Wall thickness	Core thickness	Cumulative packing [sets]
			A	A1	a	a1	H	H1	h	h1			
AKR 1	TKP3K050212209D1	3	50	21	22	9	180	187	45	50	3,0	2,5	1
AKR 2	TKP3K075313214D1	3	75	31	32	14	160	210	56	60	4,0	2,2	1
AKR 3	TKP3K110455521D1	3	110	45	55	21	160	230	53	55	3,5	2,2	1
AKR 4	TKP3K135566428D1	3	135	55	64	27	230	250	52	56	3,8	2,8	1
AKR 5	TKP3K170568528D1	3	170	56	68	28	230	250	40	65	3,8	2,8	1

Heat shrink breakout boots - type AKR, AKB, AKF

Application Heat shrink breakout boots AKR (red) AK, AKB and AKF (black ones) are designed for cable insulation at the end of mechanical casing (plastic or metal) on the overhead transmission line of MV. The heat shrink boots protect the cable against water penetration, dust, insects and other dirt. These breakout boots are meant for Low and Medium Voltage cables.

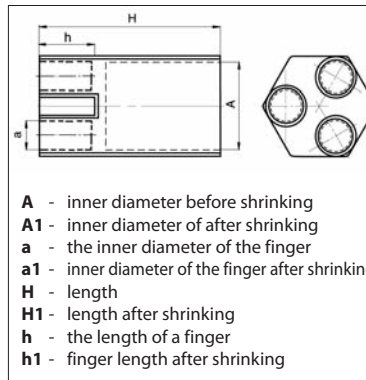

Product name	Index	Number of cores	Dimensions [mm]								Wall thickness	Core thickness	Cumulative packing [sets]
			A	A1	a	a1	H	H1	h	h1			
AKR 3	TKP3K110455521D1	3	110	45	55	21	160	230	53	55	3,5	2,2	1
AKR 4	TKP3K135566428D1	3	135	55	64	27	230	250	52	56	3,8	2,8	1
AKR 5	TKP3K170568528D1	3	170	56	68	28	230	250	40	65	3,8	2,8	1
AKB 3	TKP3K125465222C1	3	125	46	52	22	160	230	40	60	3,8	2,5	1
AKB 4	TKP3K135606426C1	3	135	60	64	26	230	250	40	65	3,8	2,8	1
AKB 5	TKP3K170568528C1	3	170	56	68	28	230	250	40	65	3,8	2,8	1
AK 4 240-400	TKP4K135515114C1	4	135	50,6	51,5	13,9	213,2	241,8	68	78,7	4,2	4,2	1
AKF1	TKP4K162706418C1	4	162	70,0	64	18	240	260	75	80	4,2	4,2	1

Properties

Operating temperature	AK, AKB, AKF: from -30 up to +135°C AKR: from -40 up to +120°C
Shrink temperature	> +125°C
Elongation at rupture	minimum 300%
Tensile strength	no less than 13 MPa
Longitudinal shrink	not more than 10%
Volume resistivity	AK, AKB, AKF: minimum 10 ¹³ Ωcm AKR: minimum 10 ¹² Ωcm
Self-extinguishing	relates to AKR
No corrosion in contact with CU	
Resistant to UV radiation	
Resistant to creeping current	(breakouts red - AKR)
Dielectric strength	minimum 10kV/mm
Resistance to heat shock	no cracks, no flow (measurement for 4 hours at 250°C)
Heat ageing	no cracks, no flow (measurement for 500 hours at 120°C)
They have excellent insulating properties and sealing	
Colours	AK, AKB, AKF: black color, AKR: red colour

Example of applications of breakout boots



Heat shrink sheds - type CES

Application

They play an integral role in installation of indoor and outdoor cable up to 72kV. Their job is to prevent occurring fault paths. CES heat shrink sheds have very good physical properties and resistance to ageing and also chemical factors.

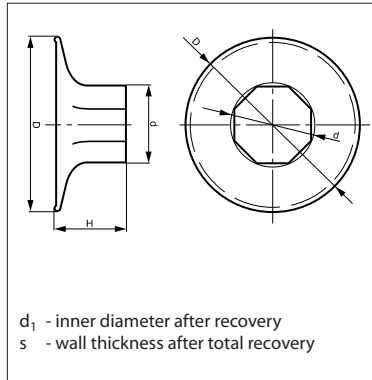

Operating temperature:

-40 up to +120°C

Shrink temperature:

>120°C

Volume resistivity:

minimum $10^{12}\Omega\text{cm}$

Dielectric strength:

minimum 10kV/mm

Heat ageing:

tested for 500 hours at a temperature 120°C - no cracks, no flowing

Product name	Index	Dimensions [mm]					Inclination angle	Cumulative packing [sets]
		D	d	d_1	s	H		
CES-1	TKC001	92	35	13	2,7	37	10°	3
CES-2	TKC002	124	47	21	2,8	40	10°	3
CES-3	TKC003	142	57	31	2,9	45	10°	3

Example of applications of sheds

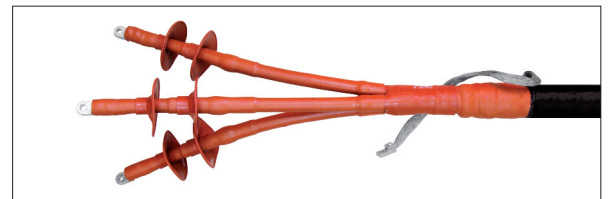

Heat shrink cable end caps - type KTK

Application

They are applied as insulation of power and telecommunication cables' ends. They also make an ideal insulation on bolts against the weather conditions at e.g. bridges or lampposts. They are resistant to acids and basics. The inner double layer of end caps - thermofusible adhesive - increases the tightness of the insulation.

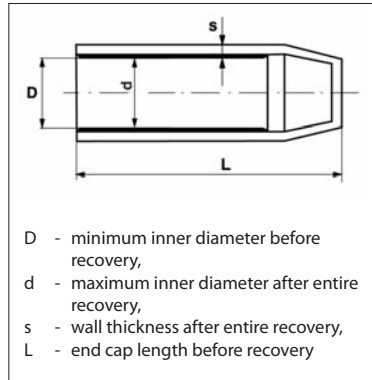

Product name	Index	Dimensions [mm]				Packing [pcs]	Cumulative packing [sets]
		D	d	s	L		
KTK 3 / 1	TKKK34001000025C0	3,4	1,0	1,0	25	100	10
KTK 4,8 / 1,5	TKKK50001500030C0	5,0	1,5	1,0	30	100	10
KTK 6 / 2	TKKK64002000030C0	6,4	2,0	1,0	30	100	10
KTK 9 / 3	TKKK10013000035C0	10,0	3,0	1,4	35	100	10
KTK 10 / 4	WKKK11014000048C0	11,0	4,0	2,4	48,5	100	100
KTK 14 / 4	WKKK14514000048C0	14,5	4,0	2,4	48,5	100	100
KTK 16 / 8	WKKK16018000085C0	16,0	7,9	2,9	85,0	100	100
KTK 18 / 6	WKKK18016000020C0	18,0	6,0	2,1	20,0	100	100
KTK 21 / 6	WKKK21016000020C0	21,0	6,0	2,1	20,0	100	100
KTK 23 / 8	WKKK23017900085C0	23,0	7,9	2,9	85,0	100	100
KTK 33 / 15	WKKK33011461106C0	33,0	14,6	3,5	106,0	100	50
KTK 40 / 15	WKKK40011461106C0	40,0	14,6	3,5	106,0	100	50
KTK 52 / 25	WKKK53012421160C0	53,0	24,2	3,5	160,0	50	10
KTK 70 / 25	WKKK70012421115C0	70,0	24,2	3,5	115,0	50	10
KTK 90 / 45	WKKK91014381160C0	91,0	43,8	4,7	160,0	10	10
KTK 120 / 60	TKKK12026001150C0	121,0	43,8	4,7	160,0	10	10
KTK 145 / 60	TKKK14526001150C0	145,0	60	4,0	150,0	10	10
KTK 160 / 82	TKKK16028201150C0	160,0	82	4,0	150,0	10	100
KTK 200 / 90	TKKM20029001160C0	200,0	90	4,2	160,0	10	100

Other dimensions of end caps: available on special request.

Heat shrink cable end caps - type KTM

Application

They are applied for the protection of spun cast concrete poles against water penetration. Inner surface of KTM end caps is covered with butyl rubber mastic which guarantee tightness of the insulation.

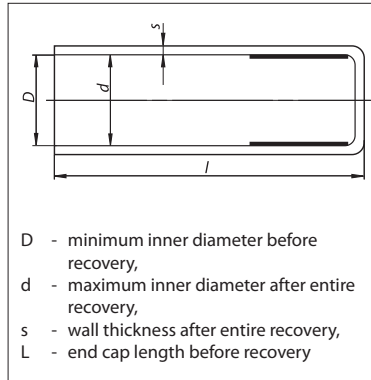

Product name	Index	Dimensions [mm]				Packing [pcs]
		D	d	s	L	
KTM 190 / 120	TKKM19021202160C0	190	120	4,2	160	1
KTM 230 / 120	TKKM23021202160C0	230	120	5,5	160	1
KTM 310 / 200	TKKM31022002160C0	310	200	5,5	160	1

Other dimensions of end caps: available on special request.

Properties	Cable end caps KTK / KTM
Operating temperature	-55 up to +105°C
Shrink temperature	from 120 up to 200°C
Tensile strength	minimum 8 MPa
Elongation at rupture	minimum 200%
Resistance to heat shock	Measured for 4 hours at + 200°C no cracks, flowing and deformation
Water absorption:	0,1% of weight (24 hours, temperature +25°C ±2)
Dielectric strength	minimum 16kV/mm
Longitudinal shrink	not more than 25%.
Resistant to UV radiation	
Colour	black

Examples of applications of end caps



Heat shrink protection kits for 0,6/1kV - type ZO 4, ZO 5

Application

Protection kits are meant for cable ends protection. They allow the operation of cable under tension of 1kV.
The cleaning tissue attached to the kit should be used for degreasing of cable surface before the installation.

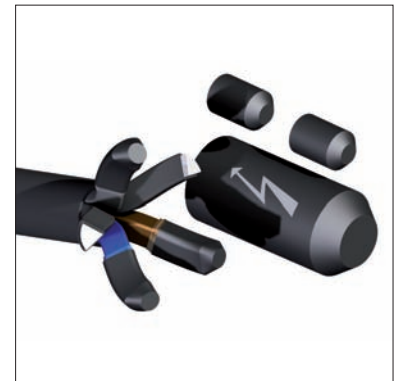

For 4-core cables

Product name	Index	Cable cross-section [mm ²]		Components of set				Cleaning tissue Quantity [pcs]
		from	to	Insulation cap		Covering cap		
				Type	Quantity [pcs]	Type	Quantity [pcs]	
ZO 4 16-25	WGE0AI4FGKK01	16	25	10 / 4 x 48,5	4	33 / 15 x 106	1	1
ZO 4 35	WGE0AI4HOKK01		35	16 / 8 x 50	4	40 / 15 x 106	1	1
ZO 4 50-70	WGE0AI4IJKK01	50	70	16 / 8 x 50	4	52 / 25 x 160	1	1
ZO 4 95-120	WGE0AI4KLKK01	95	120	23 / 8 x 50	4	52 / 25 x 160	1	1
ZO 4 150	WGE0AI4MOKK01		150	23 / 8 x 50	4	70 / 25 x 160	1	1
ZO 4 185	WGE0AI4NOKK01		185	33 / 15 x 50	4	70 / 25 x 160	1	1
ZO 4 240	WGE0AI4OOKK01		240	33 / 15 x 50	4	90 / 45 x 160	1	1

For 5-core cables

Product name	Index	Cable cross-section [mm ²]		Components of set				Cleaning tissue Quantity [pcs]
		from	to	Insulation cap		Covering cap		
				Type	Quantity [pcs]	Type	Quantity [pcs]	
ZO 5 16-25	WGE0AI5FGKK01	16	25	10 / 4 x 48,5	5	40 / 15 x 106	1	1
ZO 5 35	WGE0AI5HOKK01		35	16 / 8 x 50	5	52 / 25 x 160	1	1
ZO 5 50-70	WGE0AI5IJKK01	50	70	16 / 8 x 50	5	70 / 25 x 160	1	1
ZO 5 95-120	WGE0AI5KLKK01	95	120	23 / 8 x 50	5	70 / 25 x 160	1	1
ZO 5 150	WGE0AI5MOKK01		150	23 / 8 x 50	5	90 / 45 x 160	1	1
ZO 5 185-240	WGE0AI5NOKK01	185	240	33 / 15 x 50	5	90 / 45 x 160	1	1

Heat shrink phase markers - type ZOK, ZOKzt

Application Designed for phase marking of conductors finished with copper or aluminum lugs for installation outdoor, indoor and underground. They are good electrical insulators, they protect against mechanical and corrosion damages. The double layer hot-melt protection guarantees tightness of insulated connection.

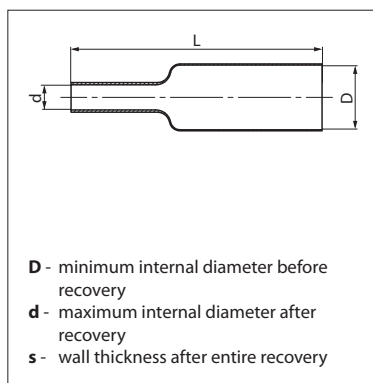

Colours: set ZOK - 4 black phase markers with white marking: L1, L2, L3 i N.
 set ZOKzt - 4 black phase markers with white marking: L1, L2, L3 i N
 and one yellow-green phase marker.

Material: made of medium wall heat shrink adhesive layered tubes (RPK).

Type of ph. marker	Index	Type of ph. marker	Index	Type of terminals		Dim. of phase marker [mm]			Cumulative packing [sets]
				Al	Cu	D	d	L	
ZOK-1	WGE0AI4FGOF01	ZOKzt-1	WGE0AI4FGOF0Z	-	16, 25	12	4	40	50
ZOK-2	WGE0AI4FJOF01	ZOKzt-2	WGE0AI4FJOF0Z	16, 25, 35	35, 50, 70	18	6	50	50
ZOK-3	WGE0AI4INOF01	ZOKzt-3	WGE0AI4INOF0Z	50, 70, 95	95, 120, 150, 185	25	10	80	50
ZOK-4	WGE0AI4LOOF01	ZOKzt-4	WGE0AI4LOOF0Z	120, 150, 185	240	32	12	100	50
ZOK-5	WGE0AI4O0OF01	ZOKzt-5	WGE0AI4O0OF0Z	240	-	40	16	120	50

Heat shrink wall ducts - type TPM

Application Meant for tight ducts through walls, ceilings, partitions. They guarantee water-proof and gas-proof insulation. They are resistant to changing weather conditions. Make good protection of cables and wires against mechanical abrasion, damages by rodents and insect penetrations.

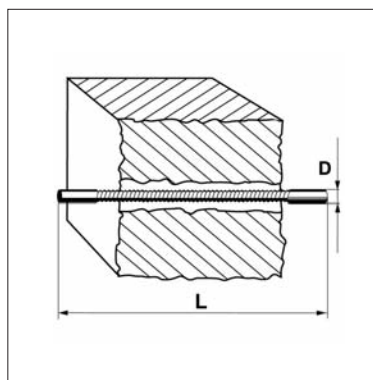

Design: They are made of heat shrink tube and galvanized steel spiral. They are supplied double layered - with adhesive.

Tye of wall ducts	Index	Dim. of heat shrink duct [mm]			Dimensions of wall [mm]	
		D	d	L	Max. wall thickness	Required diameter of wall hole
TPM 14 / 10	WKZ001	14	10	800	500	50
TPM 23 / 12	WKZ002	23	12	800	500	55
TPM 28 / 16	WKZ003	28	16	800	500	60
TPM 38 / 20	WKZ004	38	20	800	500	70
TPM 48 / 19	WKZ005	48	19	800	500	85
TPM 86 / 45	WKZ007	86	45	800	500	125

d - inner diameter after entire recovery.

Heat shrink repair wrap-arounds - type RM

Application

They are designed for installation on single cores of multicore cables. They are also used for making and repairing straight and branch power cable joints and for telecommunication cables. The wrap-arounds are supplied covered with thermosensitive paint (visible spots) which plays role of shrink temperature indicator protecting against local overheating. The spots disappear when the shrink temperature is appropriate.

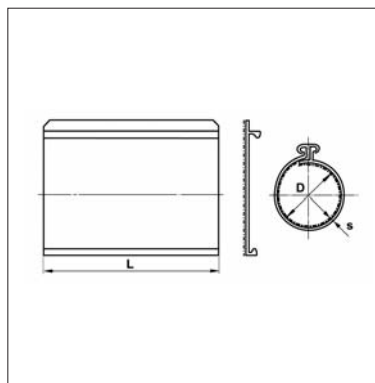

Tensile strength: minimum 13 MPa
 Longitudinal shrink: not more than 10%
 The unit dielectric strength: no less than 12kV/mm
 Resistance to UV

Product name	Index for length					Dimensions [mm]		
	250 [mm]	500 [mm]	750 [mm]	1000 [mm]	1500 [mm]	D	d	s
RM 52 / 14	TKR152011401	TKR252011401	TKR352011401	TKR452011401	TKR552011401	52	14	3,0
RM 62 / 22	TKR162012201	TKR262012201	TKR362012201	TKR462012201	TKR562012201	62	22	3,0
RM 92 / 30	TKR192013001	TKR292013001	TKR392013001	TKR492013001	TKR592013001	92	30	3,0
RM 122 / 38	TKR112223801	TKR212223801	TKR312223801	TKR412223801	TKR512223801	122	38	3,0
RM 160 / 55	TKR116025501	TKR216025501	TKR316025501	TKR416025501	TKR516025501	160	55	3,0
RM 210 / 55	TKR121025501	TKR221025501	TKR321025501	TKR421025501	TKR521025501	210	55	3,0

Heat shrink tapes - type T, TKT

Application

They are mainly applied for cable bundling, repair and insulation of damaged cables and wires and for protecting the cables against mechanical defects and corrosion.

Advised for application for any constructional joints as a tight and durable protection.

Good adherence of applied adhesive layer to metals, wood, ceramics and plastics guarantees good insulation of ventilation ducts, jacket pipes, wires, power and telecommunication cables.

The conjunctions with TKT tape aren't prone to abrasion and corrosion.



Tensile strength: minimum 13 MPa
 Longitudinal shrink: not more than 10%
 The unit dielectric strength: no less than 12kV/mm
 Resistance to UV

Type of tape	Index	Length [m]	Width [mm]	Thickness [mm]
T-25 (15m)	TTHN0025151	15	25	0,9
T-50 (15m)	TTHN0050151	15	50	0,9
T-100 (15m)	TTHN0100151	15	100	0,9

Type of tape	Index	Length [m]	Width [mm]	Thickness [mm]	Thickness of adhesive layer [mm]
TKT-25(15m)	TTHNK025151	15	25	1,0	0,1
TKT-50(15m)	TTHNK050151	15	50	1,0	0,1
TKT-75(15m)	TTHNK075151	15	75	1,0	0,1
TKT-100(15m)	TTHNK100151	15	100	1,0	0,1
TKT-150(15m)	TTHNK150151	15	150	1,0	0,1

Example of use of tapes



Heat shrink pipe end caps - type „End-Cap“

Application

Designed for insulation of cable outlets from cable ducts and for insulation of pre-insulated pipes' ends.

They seal and protect against moisture penetration.

They are applied in district heating industry, power engineering, construction engineering and telecommunication.

They are resistant to: UV radiation, corrosive agents, fungus and mildew.

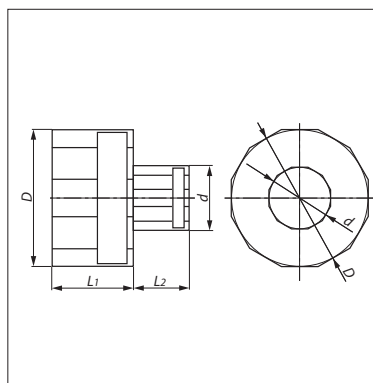

Tensile strength: minimum 13 MPa
 Longitudinal shrink: not more than 10%
 The unit dielectric strength: no less than 12kV/mm

Type of end caps	Index	End cap dimension [mm]						Cumulative packing [sets]
		D	D ₁	d	d ₁	L ₁	L ₂	
REC 50	TKE1K0600	60	30	45	10	70	50	10
REC 75	WKE1M0850	85	20	42	20	60	40	5
REC 90	WKE1M1050	105	27	45	27	60	40	5
REC 110	WKE1M1250	125	27	65	27	60	40	5
REC 125	WKE1M1400	140	35	76	35	60	40	5
REC 140	WKE1M1560	156	45	95	45	60	40	5
REC 160	WKE1M1780	178	58	105	58	80	50	5
REC 160(S)	TKE1K1700	170	92	60	20	80	40	5

Attention - dimensions D₁, d₁ diameter after entire recover.

Example of use of end caps



LOW VOLTAGE CABLE JOINTS

Straight cable joints for 0,6/1kV polymer insulated 4-core cables of type N(A)YY, N(A)2XY, Y(A)KY, Y(A)KXS



Voltage range	Cable cross-section [mm ²]	Number of cores	Type of cable joint	Index
0,6/1kV	1,5-10	4	ZRM 1,5-10*	WMEJA0I050AE0001
	16-25	4	ZRM-1/JLP-CX4 16-25	WMEJA0I040FG0001
	35-70	4	ZRM-2/JLP-CX4 35-70	WMEJA0I040HJ0001
	95	4	ZRM-3/JLP-CX4 95	WMEJA0I040K00001
	120-150	4	ZRM-4/JLP-CX4 120-150	WMEJA0I040LM0001
	185-300	4	ZRM-5/JLP-CX4 185-300	WMEJA0I040NP0001

Sets without connectors. For use with crimping connectors.

* The set can be also used for 3 and 5 core cables of cross-section 1,5 -10 mm².

Straight cable joints for 0,6/1kV polymer insulated 4-core cables of type N(A)YY, N(A)2XY, Y(A)KY, Y(A)KXS

Voltage range	Cable cross-section [mm ²] for crimping connectors	Max. dimensions [mm] of screw connector		Number of cores	Type of cable joint	Index
		Długość	Średnica			
0,6/1kV	16-50	85	22	4	ZRM 16-50/JLP-CX4 16-50	WMEJA0I040FI0001
	70-120	105	28	4	ZRM 70-120/JLP-CX4 70-120	WMEJA0I040JL0001
	150-300	145	35	4	ZRM 150-300/JLP-CX4 150-300	WMEJA0I040MP0001

Sets without connectors. For use with crimping or screw connectors.

Voltage range	Cable cross-section [mm ²] for crimping connectors	Max. dimensions [mm] of screw connector		Number of cores	Type of cable joint	Index
		Długość	Średnica			
0,6/1kV	16-70	105	22	4	ZRM 16-70/JLP-CX4 16-70	WMEJA0I040FJ0001
	95-300	145	35	4	ZRM 95-300/JLP-CX4 95-300	WMEJA0I040KP0001

Sets without connectors. For use with crimping or screw connectors.

Straight cable joints for 0,6/1kV polymer insulated 4-core cables of type NAYY, NA2XY, YAKY, YAKXS



Voltage range	Cable cross-section [mm ²]	Number of cores	Type of cable joint	Index
0,6/1kV	16	4	ZRMZ-16/JLP-CX4 16 (KA,D)	WMEJA01040F000B1
	25	4	ZRMZ-25/JLP-CX4 25 (KA,D)	WMEJA01040G000B1
	35	4	ZRMZ-35/JLP-CX4 35 (KA,D)	WMEJA01040H000B1
	50	4	ZRMZ-50/JLP-CX4 50 (KA,D)	WMEJA01040I000B1
	70	4	ZRMZ-70/JLP-CX4 70 (KA,D)	WMEJA01040J000B1
	95	4	ZRMZ-95/JLP-CX4 95 (KA,D)	WMEJA01040K000B1
	120	4	ZRMZ-120/JLP-CX4 120 (KA,D)	WMEJA01040L000B1
	150	4	ZRMZ-150/JLP-CX4 150 (KA,D)	WMEJA01040M000B1
	185	4	ZRMZ-185/JLP-CX4 185 (KA,D)	WMEJA01040N000B1
	240	4	ZRMZ-240/JLP-CX4 240 (KA,D)	WMEJA01040O000B1

Sets are supplied with Al connectors acc. to DIN standards.

Straight cable joints for 0,6/1kV polymer insulated 4-core cables of type NYY, N2XY, YKY, YKXS

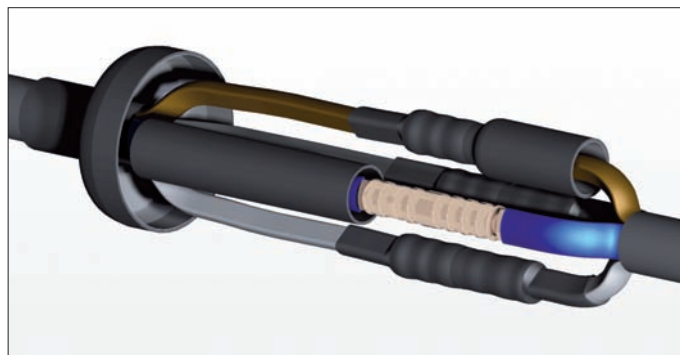

Voltage range	Cable cross-section [mm ²]	Number of cores	Type of cable joint	Index
0,6/1kV	0,5-1,5	4	JSP-CX4 0,5-1,5 (K,ZZ)	WMEJA01040QA00D1
	1,5-2,5	4	JSP-CX4 1,5-2,5 (K,ZZ)	WMEJA01040AB00D1
	4-6	4	JSP-CX4 4-6 (K,ZZ)	WMEJA01040CD00D1
	10	4	JSP-CX4 10 (K,Z)*	WMEJA01040E000C1
	16	4	JLP-CX4 16 (K,D)	WMEJA01040F000D1
	25	4	JLP-CX4 25 (K,D)	WMEJA01040G000D1
	35	4	JLP-CX4 35 (K,D)	WMEJA01040H000D1
	50	4	JLP-CX4 50 (K,D)	WMEJA01040I000D1
	70	4	JLP-CX4 70 (K,D)	WMEJA01040J000D1
	95	4	JLP-CX4 95 (K,D)	WMEJA01040K000D1
	120	4	JLP-CX4 120 (K,D)	WMEJA01040L000D1
	150	4	JLP-CX4 150 (K,D)	WMEJA01040M000D1
	185	4	JLP-CX4 185 (K,D)	WMEJA01040N000D1
	240	4	JLP-CX4 240 (K,D)	WMEJA01040O000D1

Sets are supplied with Cu connectors acc. to DIN standards. * Standard Cu connector.

Straight cable joints for 0,6/1kV polymer insulated 4-core cables of type N(A)YY, N(A)2XY, Y(A)KY, Y(A)KXS



Voltage range	Cable cross-section [mm ²]	Number of cores	Type of cable joint	Index
0,6/1kV	16-35	4	JLP-CX4 16-35 (S)	WMEJA0I040FH00S1
	25-70	4	JLP-CX4 25-70 (S)	WMEJA0I040GJ00S1
	70-120	4	JLP-CX4 70-120 (S)	WMEJA0I040JL00S1
	150-240	4	JLP-CX4 150-240 (S)	WMEJA0I040MO00S1

Sets are supplied with screw connectors.

Straight cable joints for 0,6/1kV polymer insulated 1-core cables of type N(A)YY, N(A)2XY, Y(A)KY, Y(A)KXS



Voltage range	Cable cross-section [mm ²]	Number of cores	Type of cable joint	Index
0,6/1kV	16-25	1	ZRMj-1/JLP-CX1 16-25	WMEJA0I010FG0001
	35-70	1	ZRMj-2/JLP-CX1 35-70	WMEJA0I010HJ0001
	95	1	ZRMj-3/JLP-CX1 95	WMEJA0I010K00001
	120-150	1	ZRMj-4/JLP-CX1 120-150	WMEJA0I010LM0001
	185-300	1	ZRMj-5/JLP-CX1 185-300	WMEJA0I010NP0001

Sets without connectors, one set for four single cores. For use with crimping connectors.

Straight cable joints for 0,6/1kV polymer insulated 1-core cables of type N(A)YY, N(A)2XY, Y(A)KY, Y(A)KXS

Voltage range	Cable cross-section [mm ²] for crimping connectors	Max. dimensions [mm] of screw connector		Number of cores	Type of cable joint	Index
		Length	Diameter			
0,6/1kV	16-70	105	22	1	ZRMj 16-70/JLP-CX1 16-70	WMEJA0I010FJ0001
	95-300	145	35	1	ZRMj 95-300/JLP-CX1 95-300	WMEJA0I010KP0001

Sets without connectors, one set for four single cores. For use with crimping or screw connectors.

Straight cable joints for 0,6/1kV polymer insulated 5-core cables of type N(A)YY, N(A)2XY, Y(A)KY, Y(A)KXS

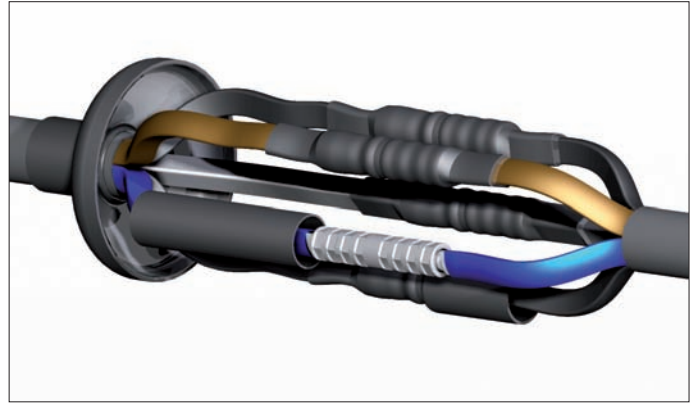

Voltage range	Cable cross-section [mm ²] for crimping connectors	Max. dimensions [mm] of screw connector		Number of cores	Type of cable joint	Index
		Długość	Średnica			
0,6/1kV	1,5-10	-	-	5	ZRM 1,5-10*	WMEJA0I050AE0001
	16-70	105	22	5	ZRMp 16-70/JLP-CX5 16-70	WMEJA0I050FJ0001
	95-300	145	35	5	ZRMp 95-300/JLP-CX5 95-300	WMEJA0I050KP0001

Sets without connectors. For use with crimping or screw connectors.

* The set can be also used for 4 and 5 core cables of cross-section 1,5 -10 mm².

Straight cable joints for 0,6/1kV paper insulated cables of type N(A)KRA, N(A)KFY, KFtA, AKFtA



Voltage range	Cable cross -section [mm ²]	Number of cores	Type of cable joint	Index
0,6/1kV	16-25	3	JLP-CF3 16-25	WMEJA0F030FG0001
	35-50	3	JLP-CF3 35-50	WMEJA0F030HI0001
	70-95	3	JLP-CF3 70-95	WMEJA0F030JK0001
	120-150	3	JLP-CF3 120-150	WMEJA0F030LM0001
	185-240	3	JLP-CF3 185-240	WMEJA0F030NO0001
	16-25	4	JLP-CF4 16-25	WMEJA0F040FG0001
	35-50	4	JLP-CF4 35-50	WMEJA0F040MK0001
	70-95	4	JLP-CF4 70-95	WMEJA0F040JK0001
	120-150	4	JLP-CF4 120-150	WMEJA0F040LM0001
	185-240	4	JLP-CF4 185-240	WMEJA0F040NO0001

Sets without connectors. For use with crimping connectors.

Straight cable joints for 0,6/1kV polymer insulated and armoured cables of type N(A)YCY, N(A)YCWY, N(A)YBY, Y(A)KYF(o, p, t, l)Y



Voltage range	Cable cross-section [mm ²]	Number of cores	Type of cable joint	Index
0,6/1kV	16-35	4	JLP-CA4 16-35	WMEJA0A040FH0001
	50-95	4	JLP-CA4 50-95	WMEJA0A040IK0001
	120-240	4	JLP-CA4 120-240	WMEJA0A040LO0001

Sets without connectors. For use with crimping connectors.

Straight cable joints for 0,6/1kV traction cables

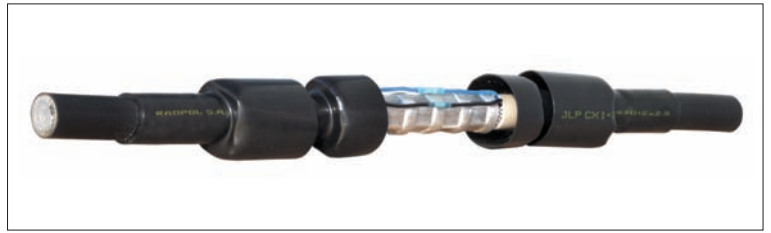
**Application**

Joints designed for joining traction cables: NYY, NAYY, NA2XY, YKY, YAKY, YKXS, YAKXS, XAKXS, XKXS.

For special orders the joints are supplied with aluminium connectors.

Traction cable: single-core polymer insulated cable, screened with drain wires or tapes (NAYY, YAKY 630/25).

Cable: NAYY, YAKY cable with test cores (NAYY, YAKY 630 + 2x2,5).

Voltage range	Cable cross-section [mm ²]	Number of cores	Type of cable joint	Index
0,6/1kV	500-630	1	JLP-CX1 500-630	WMEJA0I010ST0001
	630	1	JLP-CT1 630	WMEJA0T010T00001
	630	1+2	JLP-CX1+2 1x630+2x2,5	WMEJA0I030T0B001

Sets without connectors. For use with crimping connectors.

Straight cable joints 0,6/1kV for deep-well pumps

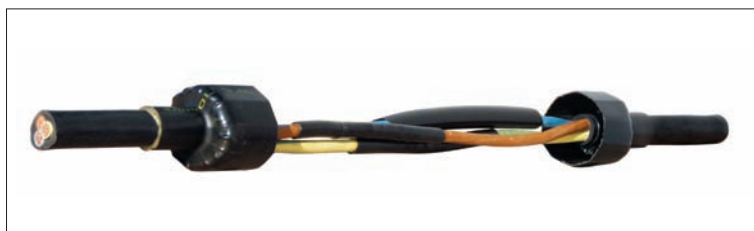

Application

Joints designed for connection of round and flat cables: H07RN-F, OGŁ, OGŁp, OW, OPd, OWY.

Joints for rubber insulated cables are designed to be installed in environment of high humidity.

Their design excludes any moisture penetration thanks to special sealant.

The joint sets are supplied with connectors of doubled length which guarantee proper mechanical strength to elongation.

Due to this the cable joints are stable and dependable.

JOP joints are designed for connection of round and flat cables.

Transition joints for the mentioned cables are supplied on special request.

Please contact our sales department.

Voltage range	Cable cross-section [mm ²]	Number of cores	Type of cable joint	Index
0,6/1kV	1,5-2,5	3	JOP-CG3 1,5-2,5 (K,Z)	WMEJA0G030AB00C1
	4	3	JOP-CG3 4 (K,Z)	WMEJA0G030C000C1
	6	3	JOP-CG3 6 (K,Z)	WMEJA0G030D000C1
	10	3	JOP-CG3 10 (K,Z)	WMEJA0G030E000C1
	16	3	JOP-CG3 16 (K,Z)	WMEJA0G030F000C1
	25	3	JOP-CG3 25 (K,Z)	WMEJA0G030G000C1
	35	3	JOP-CG3 35 (K,Z)	WMEJA0G030H000C1
	50	3	JOP-CG3 50 (K,Z)	WMEJA0G030I000C1
	1,5-2,5	4	JOP-CG4 1,5-2,5 (K,Z)	WMEJA0G040AB00C1
	4	4	JOP-CG4 4 (K,Z)	WMEJA0G040C000C1
	6	4	JOP-CG4 6 (K,Z)	WMEJA0G040D000C1
	10	4	JOP-CG4 10 (K,Z)	WMEJA0G040E000C1
	16	4	JOP-CG4 16 (K,Z)	WMEJA0G040F000C1
	1,5-2,5	5	JOP-CG5 1,5-2,5 (K,Z)	WMEJA0G050AB00C1
	4	5	JOP-CG5 4 (K,Z)	WMEJA0G050C000C1
	6	5	JOP-CG5 6 (K,Z)	WMEJA0G050D000C1
	10	5	JOP-CG5 10 (K,Z)	WMEJA0G050E000C1
	16	5	JOP-CG5 16 (K,Z)	WMEJA0G050F000C1

Supplied with copper connectors of double length for crimping.

Straight cable joints for 0,6/1kV signal cables



Application For cable types: NYY, N2XY, NYSLY, LIYY, YKY, YKSY, YKSYy, YKSXS, YnKSY.

Voltage range	Cable cross-section [mm ²]	Number of cores	Type of cable joint	Index
0,6/1kV	1,5-2,5	2	JSP-CX2 1,5-2,5 (K,ZZ)	WMEJA0I020AB00D1
	0,5-1,5	3	JSP-CX3 0,5-1,5 (K,ZZ)	WMEJA0I030QA00D1
	1,5-2,5	3	JSP-CX3 1,5-2,5 (K,ZZ)	WMEJA0I030AB00D1
	10	3	JSP-CX3 10 (K,Z)	WMEJA0I030E000C1
	0,5-1,5	4	JSP-CX4 0,5-1,5 (K,ZZ)	WMEJA0I040QA00D1
	1,5-2,5	4	JSP-CX4 1,5-2,5 (K,ZZ)	WMEJA0I040AB00D1
	4-6	4	JSP-CX4 4-6 (K,ZZ)	WMEJA0I040CD00D1
	10	4	JSP-CX4 10 (K,Z)	WMEJA0I040E000C1
	1,5-2,5	5	JSP-CX5 1,5-2,5 (K,ZZ)	WMEJA0I050AB00D1
	4-6	5	JSP-CX5 4-6 (K,ZZ)	WMEJA0I050CD00D1
	10	5	JSP-CX5 10 (K,Z)	WMEJA0I050E000C1
	0,5-1,5	6	JSP-CX6 0,5-1,5 (K,ZZ)	WMEJA0I0A0QA00D1
	0,5-1,5	7	JSP-CX7 0,5-1,5 (K,ZZ)	WMEJA0I0B0QA00D1
	1,5-2,5	7	JSP-CX7 1,5-2,5 (K,ZZ)	WMEJA0I0B0AB00D1
	4-6	7	JSP-CX7 4-6 (K,ZZ)	WMEJA0I0B0CD00D1
	0,5-1,5	10	JSP-CX10 0,5-1,5 (K,ZZ)	WMEJA0I0D0QA00D1
	1,5-2,5	10	JSP-CX10 1,5-2,5 (K,ZZ)	WMEJA0I0D0AB00D1
	4-6	10	JSP-CX10 4-6 (K,ZZ)	WMEJA0I0D0CD00D1
	0,5-1,5	14	JSP-CX14 0,5-1,5 (K,ZZ)	WMEJA0I0E0QA00D1
	1,5-2,5	14	JSP-CX14 1,5-2,5 (K,ZZ)	WMEJA0I0E0AB00D1
	1,5-2,5	19	JSP-CX19 1,5-2,5 (K,ZZ)	WMEJA0I0G0AB00D1
	1,5-2,5	24	JSP-CX24 1,5-2,5 (K,ZZ)	WMEJA0I0H0AB00D1
	1,5-2,5	30	JSP-CX30 1,5-2,5 (K,ZZ)	WMEJA0I0I0AB00D1
	0,5-1,5	37	JSP-CX37 0,5-1,5 (K,ZZ)	WMEJA0I0K0QA00D1
1,5-2,5	37	JSP-CX37 1,5-2,5 (K,ZZ)	WMEJA0I0K0AB00D1	
1,5-2,5	40	JSP-CX40 1,5-2,5 (K,ZZ)	WMEJA0I0L0AB00D1	
0,5-1,5	75	JSP-CX75 0,5-1,5 (K,ZZ)	WMEJA0I0R0QA00D1	

Joint sets are supplied with copper connectors insulated with heat shrink, for crimping.

Application For cable types: NYSLY, KSY, KSYy, KSYFt, Ksywo, KSYFtA, KSYFoA, KSYFty, KSYFoy, YKSYFpy, YKSYFty, YKSYFoy, YKSXSfpy, YKSXSfty, YKSXSfoy

Voltage range	Cable cross-section [mm ²]	Number of cores	Type of cable joint	Index
0,6/1kV	10	3	JSP-CA3 10 (K,Z)	WMEJA0A030E000C1
	1,5-2,5	4	JSP-CA4 1,5-2,5 (K,ZZ)	WMEJA0A040AB00D1
	4-6	4	JSP-CA4 4-6 (K,ZZ)	WMEJA0A040CD00D1
	10	4	JSP-CA4 10 (K,Z)	WMEJA0A040E000C1
	1,5-2,5	5	JSP-CA5 1,5-2,5 (K,ZZ)	WMEJA0A050AB00D1
	4-6	5	JSP-CA5 4-6 (K,ZZ)	WMEJA0A050CD00D1
	1,5-2,5	7	JSP-CA7 1,5-2,5 (K,ZZ)	WMEJA0A0B0AB00D1
	4-6	7	JSP-CA7 4-6 (K,ZZ)	WMEJA0A0B0CD00D1
	1,5-2,5	10	JSP-CA10 1,5-2,5 (K,ZZ)	WMEJA0A0D0AB00D1
	1,5-2,5	14	JSP-CA14 1,5-2,5 (K,ZZ)	WMEJA0A0E0AB00D1
	1,5-2,5	19	JSP-CA19 1,5-2,5 (K,ZZ)	WMEJA0A0G0AB00D1
	1,5-2,5	24	JSP-CA24 1,5-2,5 (K,ZZ)	WMEJA0A0H0AB00D1
	1,5-2,5	37	JSP-CA37 1,5-2,5 (K,ZZ)	WMEJA0A0K0AB00D1

Joint sets are supplied with copper connectors insulated with heat shrink, for crimping.

TRANSITION CABLE JOINTS 0,6/1kV**Transition cable joints 0,6/1kV with screw or compression connectors****Application**

On request we make 0,6/1kV transition cable joints with screw or compression connectors:

- Y(A)KY(-żo)
- Y(A)KXS(-żo)
- Y(A)KYFoy(-żo)
- Y(A)KYFpy(-żo)
- YAKYFtly(-żo)
- (A)KFtA
- OGŁ
- H07RN-F
- YKSY, YKSYy, YKSX, YNKSY
- KSY, KSYy, KSYFt, Ksywo, KSYFtA, KSYFoA, KSYFty, KSYFoy, YKSYFpy, YKSYFty, YKSYFoy, YKSXSFpy, YKSXSFty, YKSXSFoy,

Due to variety of cable connections requests for 0,6/1kV transition cable joints are determined individually. Please contact our sales department.

Telecommunications cable joints - type GVAM

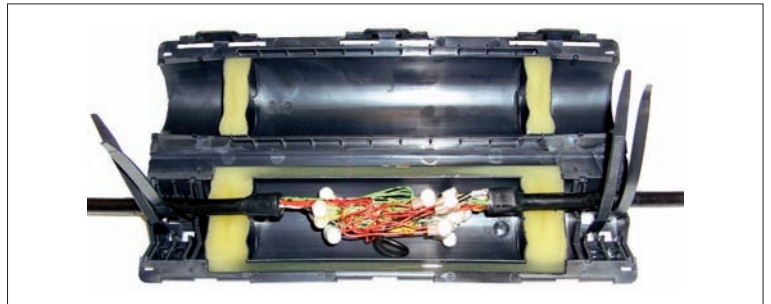

- Application:** Dedicated for connecting of polymer or rubber insulated telecommunication, signal and steering cables. Used as a straight or branch joints with the use of different types of connectors.
For cable types: XzTKMXpw, XzTKMXpwn, XzTKMXpwFtI(x)/(y), NTKMXFtIN, NTKMXpFtIN, XTKMXpwn, TKMXn, TKSy, YTKSY, YnTKSY.
- Joint content:** Joint casing, clamps, screen connectors, installation manual. Set doesn't contain connectors (available on request)
- Properties:** Joints find the application in ground, on masts, indoor, in cable ducts. They can work in environment temperature - 30 up to +80°C. Resistant to UV radiation. The set can be used multiple times and gives an opportunity to button up other cables. Joint casing is manufactured of plastics which is very resistant to hitting. water flooding (up to 4 m) and is equipped with integrated cable fastening with the use of clamps. The joint is performed in gel technology, assembly doesn't require of using propane butane torch.

Voltage range	Type of cable joint	Max. Cable diameter [mm]	Dimensions	Dimensions of middle part	Index
			Length / Diameter [mm]	Length / Diameter [mm]	
0,6/1kV	GVAM 30	23	334/80	130/50	TME1A000I0000001
	GVAM 200	37	461/160	288/100	TME1A000W0000001

Straight cast resin joints 0,6/1kV - type JLZ

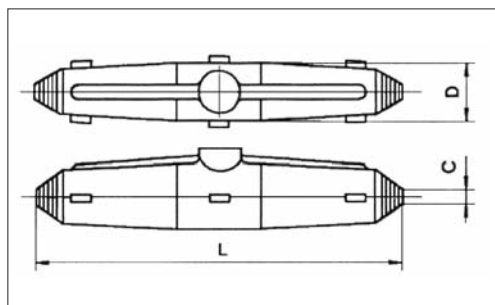
**Application:**

They are designed for joining cables of the same insulation, cross-section and number of cores.

For cable types: N(A)YY, N(A)2XY, H07RN-F, Y(A)KY, Y(A)KXS, YKSY, YKSYy, YKSX, YNKSY, OGŁ, OGŁp, OW, OPd, OWY.

Joint content:

Resin joint set consists of: two-piece mold, resin cast, polyurethane resin, insulation tape, protective gloves and connectors (on special request).

Properties:

Two-piece polyurethane resin (resin and hardener) is delivered in two containers for quick and easy mixing.

The mixed components of resin fill up the resin cast making the conjunction tight and excellent insulated.

Gloves protect hands against contact with resin.

No heat needed for installation.

Installation guide supplied along with the product.

Voltage range	Type of cable joint	Dimensions [mm]		Outer cable diameter - C [mm]	Index
		L	D		
0,6/1kV	JLZ1	202	36	8 - 26	WMEZA01000000001
	JLZ2	260	47	16 - 32	WMEZA01000000002
	JLZ3	400	70	26 - 41	WMEZA01000000003
	JLZ4	530	132	32 - 68	WMEZA01000000004
	JLZ5	700	180	45 - 70	WMEZA01000000005

Branch cast resin joints 0,6 / 1kV - type JLZR1; 2; 3

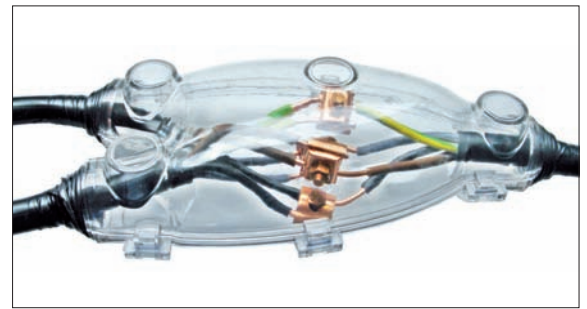
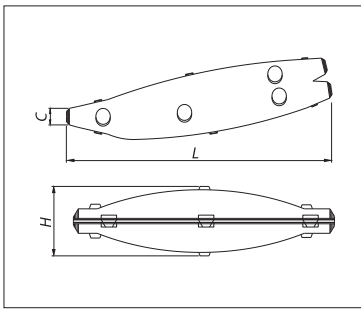

Application: They are designed for joining 3, 4 and 5-core 0,6/1kV cables of main cable cores' cross-section 1 - 35 mm² and branch cable cores' cross-section 1 - 25 mm².

Used for cables of type: N(A)YY, N(A)2XY, NYSLY, NYM, Y(A)KY, Y(A)KXS, YKSY, YDY, YLY.

Joint content: Two-piece transparent cast, polyurethane resin, insulation mass, protective gloves, instruction manual. The set doesn't contain branch grips (available on request).

Properties Joints guarantee full tightness thanks to it they can be applied in ground and water, cable ducts and indoors. No special tools and heat sources needed during the assembling. Wide range of application along with the small size of the set are the most important advantages of new joints which are appreciated by the installers daily assembling the most popular cables and wires. Installation guide supplied along with the product.

Voltage range	Type of cable joint	Main cable cores' cross-section [mm ²]	Branch cable cores' cross-section [mm ²]	Width H [mm]	Length L [mm]	Hole diameter C [mm]		Index
						min.	max	
0,6/1kV	JLZR1	3x2,5÷10 4x1,5÷6 5x1÷4	3x2,5÷4 4x1,5÷2,5 5x1÷2,5	45	150	10	19	WMEYA01000000001
	JLZR2	3x2,5÷16 4x2,5÷10 5x1,5÷6	3x2,5÷6 4x1,5÷4 5x1,5÷4	66	175	6	21	WMEYA01000000002
	JLZR3	3x6÷35 4x4÷25 5x2,5÷10	3x2,5÷25 4x2,5÷16 5x2,5÷10	70	225	9	24	WMEYA01000000003

Joints hold a positive technical approving issued by Institute of Power Engineering in conformity with requirements of norm PN-EN 50393:2006.

Branch cast resin joints 0,6 / 1kV - type JLZR4; 5; 6; 7

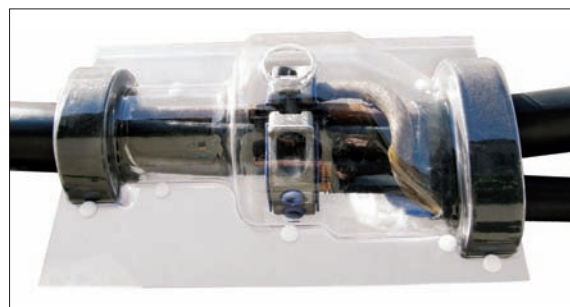
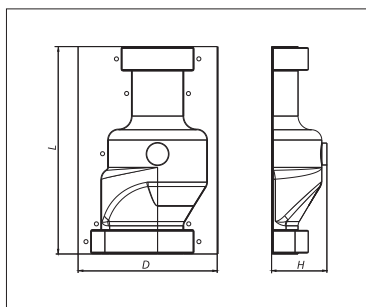

Application

They are designed for joining 4-core 0,6/1kV cables of main cable cores' cross-section 16 - 240 mm² and branch cable cores' cross-section 6 - 70 mm².

Used for cables of type: N(A)YY, N(A)2XY, Y(A)KY, Y(A)KXS

Joint content:

Two-piece transparent cast, polyurethane resin, sealing sponges, branch ferrule, protective gloves, instruction manual.

Properties:

No special tools and heat sources needed during the assembling. The cast is perfectly matched to the connection. It doesn't require any additional cutting. The place of cable connection is excellently visible.

Applied branch ferrule enable cables joining without necessity of cutting them. Assembling is carried out by using of hex wrench. Polyurethane resin is supplied in two-part bag enabling quick and easy mixing.

The resin mixture fully fills up the resin cast. It is also resistant to UV radiation and chemical factors.

The joint guarantee full tightness of the connection thanks to it they can be applied in ground and water, cable ducts and indoors.

Voltage range	Type of cable joint	Main cable cores' cross-section [mm ²]	Branch cable cores' cross-section [mm ²]	Number of cores	Dimensions [mm]			Index
		RM, SM/RE, SE			L	D	H	
0,6/1kV	JLZR4	16-25 / 25-35	6-50	4	253	165	61,5	WMEYA0I000000004
	JLZR5	35-50 / 35-70	6-50	4	303	177	63,5	WMEYA0I000000005
	JLZR6	70-120 / 95-150	6-70	4	303	200	76,5	WMEYA0I000000006
	JLZR7	185-240 / 185-240	6-70	4	303	205	81,5	WMEYA0I000000007

Joints hold a positive technical approving issued by Institute of Power Engineering in conformity with requirements of norm PN-EN 50393:2006.

Polyurethane resin, type RPU



Application: It is used for the reconstruction of the insulation of polymer, paper or rubber insulated power, signal and telecommunication cables for the rated voltage of 0,6/1 (1,2) kV.

Properties: The package with resin has been designed and made in such way that it could be quickly, easy and effectively used by the installer. Properly matched proportions of two-component polyurethane resin are separated by the special plastic separator which when removed, enables mixing of the resin with the hardener. Mixture created in such way is characterized by perfect adhesion, resistance to hydrolysis and is ready to be used for the cables as the insulation and mechanical covering.

Max. storage time in temperature from 15°C to 35°C - 48 months.

Type of resin	Volume [ml]	Index
RPU 464	464	TDZ005
RPU 730	730	TDZ001
RPU 1000	1000	TDZ002

Properties	Value	Requirements for the norm DIN VDE 0291
Max. using time after mixing		
5°C	35 min	Accordance with product data (±30%)
23°C	20 min	
35°C	15 min	
Base component Ignition temperature	>200°C	>55°C
Resistance to elongation	≥8,0 Mpa	≥5,0
Heat ageing	-5 Shore A	-7
Adherence	>1500 CP.S	<1500
Elongation at rupture	≥100%	≥50
Gelation time 300 ml	23°C	Accordance with product data (±10%)
Packing >1000 ml	26 min	
Packing <1000 ml	17 min	Accordance with product data (±10%)
Max. reaction temperature	60°C	Accordance with product data (±10%)
Density change after harden	6%	Max. 6,5%
Assimilate component Ignition temperature	>200°C	>100°C
Density	1,07 g/cm ³	-

Properties	Value	Requirements for the norm DIN VDE 0291
Resistance to blowing	>10kJ/m ²	>10kJ/m ²
Hardness	75 Shore A	Min. 20 Shore D
Thermal extension factor 20-50°C	5,9x10 ⁻⁴ K ⁻¹	Accordance with product data (±15%)
Thermal conductivity	0,2w x m ⁻¹ x K ⁻¹	Accordance with product data (±20%)
Flammability	Class II c	Accordance with DIN VDE 0304 cz.3
Water absorption 42 days in temp. 50°C	360 mg	Max. 400 mg
Electrolytic corrosion	1	-
Tension test		No breakdown
23°C	>20kV	20kV
80°C	>10kV	20kV
Dispersion of insulation material factor		
23°C i 50Hz	0,08	Max. 0,1
23°C i 1kHz	0,05	-
Resistance to creeping current 23°C i 50Hz	5	<6
23°C i 1kHz	5,1	-
Resistance to creeping current	KA 3c	Min. KA 3c
Resistance to hydrolysis after submersion in water 90°C		
Resistance to elongation	8,2N/mm ²	≥65% of initial value
Elongation at rupture	60%	≥65% of initial value
Hardness	47 Shore	≥65% of initial value

MEDIUM VOLTAGE CABLE JOINTS

Straight cable joints for 3-core unscreened polymer insulated cables

3.6/6kV



Application: designed for joining cables of type: NYY, NAYY, YKY, YAKY.

Technical information: Heat shrink thick wall adhesive-layered tubes used for reconstruction of cores and connectors insulation. Additional insulation space is guaranteed by polyethylene spacer situated between the phase cores. Drain wire is reconstructed with the use of tinned copper sleeve installed by spring clips. Covering of the joint is formed by the heat shrink thick wall adhesive-layered tube.

Properties of the joints:

- cover full range of cable cross-sections,
- insulation layer of very high pressing strength,
- high electrical and mechanical resistance due to heat shrink thick wall adhesive-layered tubes,
- applied heat shrink tubes protect against moisture penetration.

Voltage range	Cable cross-section [mm ²]	Type of cable joint	Index
3,6/6kV i 6/6kV	25-120	JHP-6-CX3 25-120	WMEJB0I030GL0001
	95-240	JHP-6-CX3 95-240	WMEJB0I030KO0001

Sets don't contain connectors. Joint sets are meant for joining cables with the use of compression connectors. Joint set can be used for cables with copper wire screen or with drain tapes.

Straight cable joints for 3-core unscreened polymer insulated and armoured cables



3.6/6kV

Application:

for joining cables of type: N(A)YCY, N(A)YCWY, YAKYFty, YKYFty, YAKYFpy, YKYFpy, YAKYFoy, YKYFoy.

Technical information:

heat shrink thick wall adhesive-layered tubes used for reconstruction of cores and connectors insulation. Additional insulation space is guaranteed by polyethylene spacer situated between the phase cores. Drain wire and metal armour are reconstructed with the use of tinned copper sleeve installed by spring clips. Covering of the joint is formed by the heat shrink thick wall adhesive-layered tube.

Properties of the joints:

- cover full range of cable cross-sections,
- insulation layer of very high pressing strength,
- high electrical and mechanical resistance due to heat shrink thick wall adhesive-layered tubes,
- applied heat shrink tubes protect against moisture penetration.

Voltage range	Cable cross-section [mm ²]	Type of cable joint	Index
3,6/6kV i 6/6kV	25-120	JHP-6-CA3 25-120	WMEJB0A030GL0001
	95-240	JHP-6-CA3 95-240	WMEJB0A030KO0001

Sets don't contain connectors. Joint sets are meant for joining cables with the use of crimping connectors.

Cable straight joints for 1-core unscreened armoured polymer insulated traction cables

3.6/6kV
6/6kV

- Application:** Designed to connect cables: Y(A)KYFty, Y(A)KYFpy, Y(A)KYFoy.
- Technical information:** Isolation of the joint and wire formed by a heat shrink thick-wall adhesive-layered tube. The return wire and metal armour are reconstructed with the use of tinned copper sleeve installed using spring clips with constant contact pressure.
- Properties of the joint:** The joint is protected by a thick-wall adhesive-layered tube.
- insulating layer with a high clamping pressure.
 - high electrical and mechanical strength thanks to the thick-wall adhesive-layered tubes used.
 - thick-wall adhesive-layered tube protects against moisture penetration.

Voltage range	Cable cross-section [mm ²]	Type of cable joint	Index
3,6/6kV 6/6kV	150-500	JHP-6-CA1 150-500	WMEJB0A030MS0001

The set is made as a single phase. Connectors not included.
For connecting cables with the use of press connectors.

Straight cable joints for single-core screened polymer insulated cables with copper wire screen

6/10kV
8,7/15kV
12/20kV



Application:

for joining cables of type: N(A)2XS(2)Y, N(A)2XS(F)(L)(2)Y, YH(A)KXS, XUH(A)KXS, XH(A)KXS, X(RU)H(A)KXS.

Technical information:

the set contains stress control mastic which is wrapped around the screens' terminations and the connector's surface. It is used for preliminary controlling of the electrical field and filling up the space between insulation and connector's endings. The joint is supplied with stress control tubing which is shaping the electromagnetic field distribution on the whole connection length, insulation and double-layer tube with integrated layers: inner insulation, outer semiconducting. Outer semiconducting layer reconstructs the cable's screen and increases the insulation layer's pressure strength. This design guarantees the perfect adhesion of all tubes in the joint. Copper mesh applied on the whole joint length increases the mechanical resistance of the joint and improves the heat venting from the drain wire. Drain wire is being connected by screw or compression connectors additionally protected by the heat shrink tube. Reconstruction of the cable jacket is made by heat shrink thick wall adhesive-layered tube guaranteeing good adhesion of the tube to the cable's outer surface. Plastic mass applied at the joints endings protects against moisture penetration.

Properties of the joints:

- for cables with cross-sections up to 400 mm² (concerns joints with screw connectors),
 - in case of joints with screw connectors they limit the number of tools necessary for the assembling,
 - thermoplastic stress control mastic applied in the joint prevents from appearing of the incomplete discharges,
 - high electrical and mechanical resistance,
 - guarantee reliable and long-life work of the power line,
 - short assembling time thanks to simple construction and attached installation guide,
- Positive technical approving issued by Institute of Power Engineering in conformity with requirements of norms PN-90/E-06401 i PN-HD 629.1 S2:2006.

Voltage range	Cable cross-section [mm ²]	Type of cable joint	Index
6/10kV	50-150	JHP-10-CX1 50-150 (S)	WMEJC0I010IM00S1
	150-240	JHP-10-CX1 150-240 (S)	WMEJC0I010MO00S1
	240-400	JHP-10-CX1 240-400 (S)	WMEJC0I010OR00S1
8,7/15kV	50-150	JHP-15-CX1 50-150 (S)	WMEJD0I010IM00S1
	120-240	JHP-15-CX1 120-240 (S)	WMEJD0I010LO00S1
	185-400	JHP-15-CX1 185-400 (S)	WMEJD0I010NR00S1
12/20kV	50-150	JHP-20-CX1 50-150 (S)	WMEJE0I010HM00S1
	95-240	JHP-20-CX1 95-240 (S)	WMEJE0I010KO00S1
	185-400	JHP-20-CX1 185-400 (S)	WMEJE0I010NR00S1

Sets made as single-phase. Complete contain screw connectors.



Voltage range	Cable cross-section [mm ²]	Type of cable joint	Index
6/10kV	50-70	JHP-10-CX1 50-70	WMEJC0I010IJ0001
	95-150	JHP-10-CX1 95-150	WMEJC0I010KM0001
	185-240	JHP-10-CX1 185-240	WMEJC0I010NO0001
8,7/15kV	35-50	JHP-15-CX1 35-50	WMEJD0I010HI0001
	50-120	JHP-15-CX1 50-120	WMEJD0I010IL0001
	150-240	JHP-15-CX1 150-240	WMEJD0I010MO0001
12/20kV	35-95	JHP-20-CX1 35-95	WMEJE0I010HK0001
	120-240	JHP-20-CX1 120-240	WMEJE0I010LO0001

Sets made as single-phase. Sets don't contain connectors. For joining cables with the use of crimping connectors.

Straight cable joints for 3-core screened saturated paper insulated and armoured cables with common metal sheath

3.6/6kV
6/10kV



Application: for joining cables of type: N(A)KRA, N(A)KFY, N(A)KRY, AKnFtA, AKnFpA, AKnFt, AKnFp, AKnFty, AKnFpy, KnFtA, KnFpA, KnFt, KnFp.

Technical information: insulation of the particular cable's cores isolation is made with the use of transparent tubes which are resistant to cable saturant. Heat shrink breakout boot with the filling mastic seals the cores' outlets and metal sheath termination. Heat shrink thick wall adhesive-layered tubes are applied for reconstruction of cores and connectors insulation. Additional insulation space is guaranteed by polyethylene spacer situated between the phase cores. The interior of the joint is filled with the three-cornered insulation mastic. Metal sheath and armour are reconstructed with the use of tinned copper sleeve installed by spring clips. Covering of the joint is formed by the heat shrink thick wall adhesive-layered tube.

Properties of the joints:

- cover full range of cable cross-sections,
- high electrical and mechanical resistance due to heat shrink thick wall adhesive-layered tubes,
- made of materials resistant to cable saturant,
- guarantee reliable and long-life work of the power line.

Positive technical approving issued by Institute of Power Engineering in conformity with requirements of norm PN-90/E-06401.

Voltage range	Cable crosssection [mm ²]	Type of cable joint	Index
3,6/6kV	16-50	JHP-6-CF3 16-50	WMEJB0F030FI0001
	70-120	JHP-6-CF3 70-120	WMEJB0F030JL0001
	150-240	JHP-6-CF3 150-240	WMEJB0F030MO0001
6/10kV	16-50	JHP-10-CF3 16-50	WMEJC0F030FI0001
	70-120	JHP-10-CF3 70-120	WMEJC0F030JL0001
	150-185	JHP-10-CF3 150-185	WMEJC0F030MN0001
	240	JHP-10-CF3 240	WMEJC0F030O00001

Sets don't contain connectors. For joining cables with the use of crimping connectors.

Straight cable joints for 3-core screened saturated paper insulated and armoured cables with common metal sheath

8,7/15kV
12/20kV



Application:

for joining cables of type: NH(A)KBA, NH(A)KY, H(A)KnF(t, p)A, H(A)KnF(t, p)y, H(A)Kny.

Technical information:

the set contains stress control mastic and tubing which are applied for controlling of the electrical field on connectors, individual cores' screens terminations and metal sheath. Oil-proof insulation tubes increase the electrical resistance of the connected cables. Reconstruction of the particular cores' screens is made with the use of heat shrink double-layer tubes. Copper mesh along with two earthing straps guarantee conducting of high short-circuit current and regular heat venting from the connection. Heat shrink thick wall adhesive-layered tube used for covering reconstruction and insulation mastic guarantee full protection against moisture penetration..

Properties of the joints:

- universal application for cables of two voltage levels: 8,7/15kV and 12/20kV,
- resistant to difficult environmental conditions, full protection against moisture penetration,
- in case of joints with screw connectors they limit the number of tools necessary for the assembling,
- guarantee reliable and long-life work of the power line,
- high electrical and mechanical resistance.

Positive technical approving issued by Institute of Power Engineering in conformity with requirements of norm PN HD 629.2 S2:2006.

Voltage range	Cable cross-section [mm ²]	Type of cable joint	Index
8,7/15 kV	35-150	JHP-20-CF3 35-150	WMEJE0F030H0M001
i 12/20kV	95-240	JHP-20-CF3 95-240	WMEJE0F030K0O001

Sets don't contain connectors. Joint sets are meant for joining cables with the use of crimping connectors.

Voltage range	Cable cross-section [mm ²]	Type of cable joint	Index
8,7/15 kV	50-150	JHP-20-CF3 50-150 (S)	WMEJE0F030H0M0S1
i 12/20kV	95-240	JHP-20-CF3 95-240 (S)	WMEJE0F030K0O0S1

Joint sets are supplied with screw connectors.

Transition cable joints 3,6/6kV from 3-core polymer insulated cable to 3-core paper insulated cable



3,6/6kV

Application:
for joining 3-core unscreened polymer insulated cables of type NAYY, YAKY with 3-core armoured, saturated paper insulated cables with common metal sheath e.g.: NAKRY, NAKFY, NAKRY, AKnFtA, AKnFpA, AKnFt, AKnFp, AKnFty, AKnFpy.

Voltage range	Cable cross-section [mm ²]	Number of cores		Type of cable joint	Index
		Polymer insulated cable	Paper insulated cable		
3,6/6kV	35	3	3	JHP-6-CX/CF 3/3 35/35 (KA/KA,D)	WMETB0IF33H0H0B1
	50	3	3	JHP-6-CX/CF 3/3 50/50 (KA/KA,D)	WMETB0IF33I0I0B1
	70	3	3	JHP-6-CX/CF 3/3 70/70 (KA/KA,D)	WMETB0IF33J0J0B1
	95	3	3	JHP-6-CX/CF 3/3 95/95 (KA/KA,D)	WMETB0IF33K0K0B1
	120	3	3	JHP-6-CX/CF 3/3 120/120 (KA/KA,D)	WMETB0IF33L0L0B1
	150	3	3	JHP-6-CX/CF 3/3 150/150 (KA/KA,D)	WMETB0IF33M0M0B1
	185	3	3	JHP-6-CX/CF 3/3 185/185 (KA/KA,D)	WMETB0IF33N0N0B1
	240	3	3	JHP-6-CX/CF 3/3 240/240 (KA/KA,D)	WMETB0IF33O0O0B1

Joint sets are supplied with aluminium crimping connectors with partitions acc. to DIN standards.

Application:
for joining 3-core unscreened polymer insulated cables of types NACWY, YAKYFty, YAKYFpy, YAKYFoy, YAKXS-Fty with 3-core armoured, saturated paper insulated cables with common metal sheath e.g. NAKRY, NAKFY, NAKRY, AKnFtA, AKnFpA, AKnFt, AKnFp, AKnFty, AKnFpy.

Voltage range	Cable cross-section [mm ²]	Number of cores		Type of cable joint	Index
		Polymer insulated cable	Paper insulated cable		
3,6/6kV	35	3	3	JHP-6-CA/CF 3/3 35/35 (KA/KA,D)	WMETB0AF33H0H0B1
	50	3	3	JHP-6-CA/CF 3/3 50/50 (KA/KA,D)	WMETB0AF33I0I0B1
	70	3	3	JHP-6-CA/CF 3/3 70/70 (KA/KA,D)	WMETB0AF33J0J0B1
	95	3	3	JHP-6-CA/CF 3/3 95/95 (KA/KA,D)	WMETB0AF33K0K0B1
	120	3	3	JHP-6-CA/CF 3/3 120/120 (KA/KA,D)	WMETB0AF33L0L0B1
	150	3	3	JHP-6-CA/CF 3/3 150/150 (KA/KA,D)	WMETB0AF33M0M0B1
	185	3	3	JHP-6-CA/CF 3/3 185/185 (KA/KA,D)	WMETB0AF33N0N0B1
	240	3	3	JHP-6-CA/CF 3/3 240/240 (KA/KA,D)	WMETB0AF33O0O0B1

Joint sets are supplied with aluminium crimping connectors with partitions acc. to DIN standards.

Due to variety of cable connections requests for 3,6/6kV transition cable joints are determined individually.. Please contact our sales department.

Transition cable joints from 3-core screened saturated paper insulated and armoured cable with common metal sheath to three single core extruded and screened polymer insulated cables with copper wire screen

8,7/15kV
12/20kV



Application:

for joining cables of type: NH(A)KBA, NH(A)KY, H(A)KnF(t, p)A, H(A)KnF(t, p)y, H(A)Kny with cables N(A)2XS(2)Y, N(A)2XS(F)(L)(2)Y, YH(A)KXS, XH(A)KXS, XUH(A)KXS, XRUH(A)KXS.

Technical information:

in the initial stage of preparing for the assembling, paper insulated cable is transformed into polymer insulated cable with the use of transparent heat shrink thin wall tubes and 3-core breakout boot. Cores are being joined by leakproof connectors with partition. The joint set contains stress control mastic and tubing which are applied for controlling of the electrical field on connectors, individual cores' screens terminations and metal sheath. Insulation tubes increase the electrical resistance of the construction, double-layer tubes reconstruct the individual cores' screens.

Spring clips guarantee the proper connection of the polymer cables' copper wire screen with the metal sheath and armour of the paper cable. Full protection against moisture penetration is ensured by heat shrink thick wall adhesive-layered tubes for the jacket reconstruction, heat shrink 3-core breakout boot closing the connection from the side of polymer cables and insulation mastic.

Properties of the joints:

- universal application for cables of two voltage levels: 8,7/15kV i 12/20kV,
- resistant to difficult environmental conditions, full protection against moisture penetration, can work under water,
- in case of joints with screw connectors they limit the number of tools necessary for the assembling,
- guarantee reliable and long-life work of the power line,
- high electrical and mechanical resistance.

Positive technical approving issued by Institute of Power Engineering in conformity with requirements of norm PN-HD 629.2 S2:2006.

Voltage range	Cable cross-section [mm ²]	Type of cable joint	Index
8,7/15 kV	35-150	JHP-20-CF/CXd 3/1 35-150/35-150	WMETE0FD31HMHM01
i 12/20kV	95-240	JHP-20-CF/CXd 3/1 95-240/95-240	WMETE0FD31KOKO01

Sets don't contain connectors. Joint sets are meant for joining cables with the use of compression connectors. Should be used with MV leakproof cable connectors with partition.

Voltage range	Cable cross-section [mm ²]	Type of cable joint	Index
8,7/15 kV	50-150	JHP-20-CF/CXd 3/1 50-150/50-150 (S)	WMETE0FD31HMMS1
i 12/20kV	95-240	JHP-20-CF/CXd 3/1 95-240/95-240 (S)	WMETE0FD31KOKOS1

Joint sets are supplied with screw connectors. It is possible to buy repair transition joints with additional tinned copper sleeve which extends length of copper wire screen of 1-core polymer insulated cables

Straight cable joints for screened rubber insulated cables with three service cores and three protection cores

3.6/6kV



Application:

for joining wires of type: NTSCGEWOU, OGb, OGc, OnGcekğz-G, OnGbekğz-G.

Technical information:

Tinned mining connectors are used for joining service cores and protection cores. Screens made of rubber semiconducting on service cores and their insulation, are reconstructed on protection cores with the use of semiconducting self-bond tapes. Heat shrink thick wall adhesive-layered tubes are used for reconstruction of connectors insulation. The area of connection is filled with insulation mastic. Covering is reconstructed with the use of two heat shrink thick wall self-extinguishing tubes with doublesealing (thermofusible adhesive and mastic).

Properties of the joints:

- guarantee durable cables' connection thanks to threaded mining connectors,
- flexible connection resistant to difficult working conditions such as opencast mines,
- high electrical and mechanical resistance due to heat shrink thick wall adhesive-layered tubes,
- guarantee covering reconstruction with the use of flame-retardant heat shrink thick wall adhesive-layered tube,
- anti-moisture barrier in the form of insulation and filling mastic.

Positive technical approving issued by EMAG 03/04.

Voltage range	Cable cross-section [mm ²]	Number of cores	Type of cable joint	Index
3,6/6kV	3x16 + 3x16/3	3+1/3	JHP-6-CG4 3x16 + 3x16/3 (K,D)	WMGJB0G0A0FF00D1
	3x25 + 3x16/3	3+1/3	JHP-6-CG4 3x25 + 3x16/3 (K,D)	WMGJB0G0A0GF00D1
	3x35 + 3x16/3	3+1/3	JHP-6-CG4 3x35 + 3x16/3 (K,D)	WMGJB0G0A0HF00D1
	3x50 + 3x25/3	3+1/3	JHP-6-CG4 3x50 + 3x25/3 (K,D)	WMGJB0G0A0IG00D1
	3x70 + 3x35/3	3+1/3	JHP-6-CG4 3x70 + 3x35/3 (K,D)	WMGJB0G0A0JH00D1
	3x95 + 3x50/3	3+1/3	JHP-6-CG4 3x95 + 3x50/3 (K,D)	WMGJB0G0A0KI00D1
	3x120 + 3x70/3	3+1/3	JHP-6-CG4 3x120 + 3x70/3 (K,D)	WMGJB0G0A0LJ00D1

Joint sets are supplied with mining tinned copper connectors acc. to DIN standards.

Straight cable joints for screened rubber insulated cables with three service cores and three protection cores

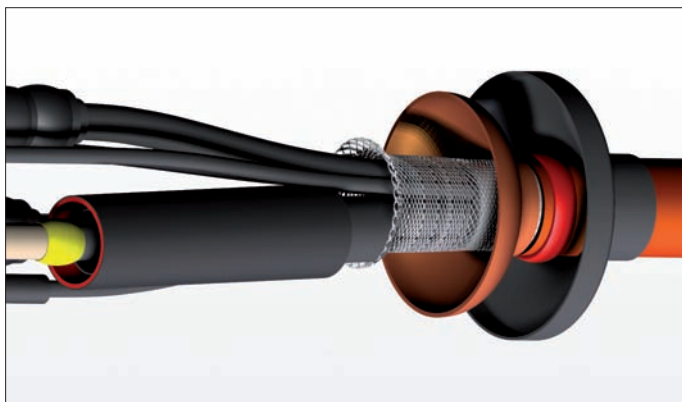

6/10kV

Application:
for joining mining wires of type: NTSCGEWOU, OnGcekgz-G (S), OnGcekgz-G (Z), OnGcrekgz-G (S), OnGcrekgz-G (Z) 6/10kV.

Technical information:

tinned mining connectors are used for joining service cores and protection cores. Stress control mastic is wrapped around the screens' terminations and the connector's surface. They are used for preliminary controlling of the electrical field and filling up the space between insulation and connector's endings.

The joint is supplied with stress control tubing which is shaping the electromagnetic field distribution on the whole connection length, insulation and double-layer tube with integrated layers: inner insulation and outer semiconducting. Heat shrink thick wall adhesive-layered flame-retardant tube is used for reconstruction of the outer covering. Protection against moisture penetration is guaranteed by applied both thermofusible adhesive and mastic.

Properties of the joints:

- guarantee durable wires' connection thanks to threaded mining connectors,
- cover cable cross-sections up to 185 mm² of service core and up to 95 mm² of protection core,
- thermoplastic stress control mass applied in the joint set prevents from incomplete discharges occurring,
- high electrical and mechanical durability, resistance to difficult working conditions such as opencast mines,
- guarantee reliable and long-life work of the power line,
- anti-moisture barrier in the form of insulation and filling masses.

Positive technical approving issued by Institute of Power Engineering in conformity with requirements of norm PN-HD 629.1 S2:2006.

Voltage range	Cable cross-section [mm ²]	Number of cores	Type of cable joint	Index
6/10kV	3x16 + 3x16/3	3+1/3	JHP-10-CG4 3x16 + 3x16/3 (K,D)	WMGJC0G0A0FF00D1
	3x25 + 3x16/3	3+1/3	JHP-10-CG4 3x25 + 3x16/3 (K,D)	WMGJC0G0A0GF00D1
	3x35 + 3x16/3	3+1/3	JHP-10-CG4 3x35 + 3x16/3 (K,D)	WMGJC0G0A0HF00D1
	3x50 + 3x25/3	3+1/3	JHP-10-CG4 3x50 + 3x25/3 (K,D)	WMGJC0G0A0IG00D1
	3x70 + 3x35/3	3+1/3	JHP-10-CG4 3x70 + 3x35/3 (K,D)	WMGJC0G0A0JH00D1
	3x95 + 3x50/3	3+1/3	JHP-10-CG4 3x95 + 3x50/3 (K,D)	WMGJC0G0A0KI00D1
	3x120 + 3x70/3	3+1/3	JHP-10-CG4 3x120 + 3x70/3 (K,D)	WMGJC0G0A0LJ00D1
	3x150 + 3x70/3	3+1/3	JHP-10-CG4 3x150 + 3x70/3 (K,D)	WMGJC0G0A0MJ00D1
	3x185 + 3x95/3	3+1/3	JHP-10-CG4 3x185 + 3x95/3 (K,D)	WMGJC0G0A0NK00D1

Joint sets are supplied with mining tinned copper connectors acc. to DIN standards.

LOW VOLTAGE CABLE TERMINATIONS

Cable terminations 0,6/1kV for polymer insulated cables of type: N(A)YY, N(A)2XY, Y(A)KY, Y(A)KXS

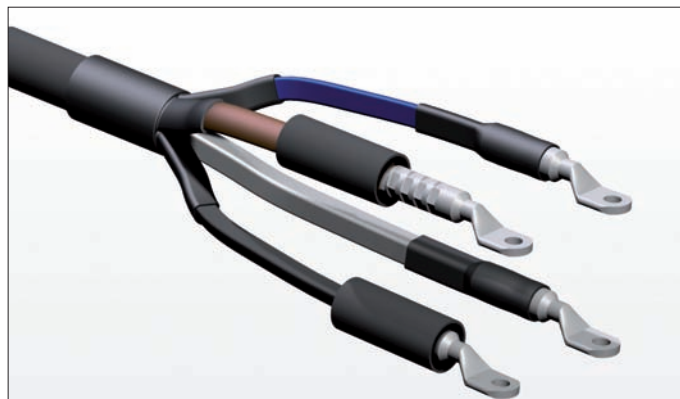

Voltage range	Cable cross-section [mm ²]	Number of cores	Type of cable termination	Index
0,6/1kV	16-35	3	TLP-CX3 16-35	WGE0AI3FH0001
	50-70	3	TLP-CX3 50-70	WGE0AI3IJ0001
	95-120	3	TLP-CX3 95-120	WGE0AI3KL0001
	150-240	3	TLP-CX3 150-240	WGE0AI3MO0001
	16-35	4	TLP-CX4 16-35	WGE0AI4FH0001
	50-70	4	TLP-CX4 50-70	WGE0AI4IJ0001
	95-120	4	TLP-CX4 95-120	WGE0AI4KL0001
	150-240	4	TLP-CX4 150-240	WGE0AI4MO0001
	10-16	5	TLP-CX5 10-16	WGE0AI5EF0001
	25-50	5	TLP-CX5 25-50	WGE0AI5GI0001
	70-120	5	TLP-CX5 70-120	WGE0AI5JL0001
	150-240	5	TLP-CX5 150-240	WGE0AI5MO0001

Sets don't contain cable lugs. For termination cables with the use of crimping lugs.

Cable terminations 0,6/1kV for rubber insulated cables of type: H07RN-F, OGI, H07RN-F, H07BN4-F

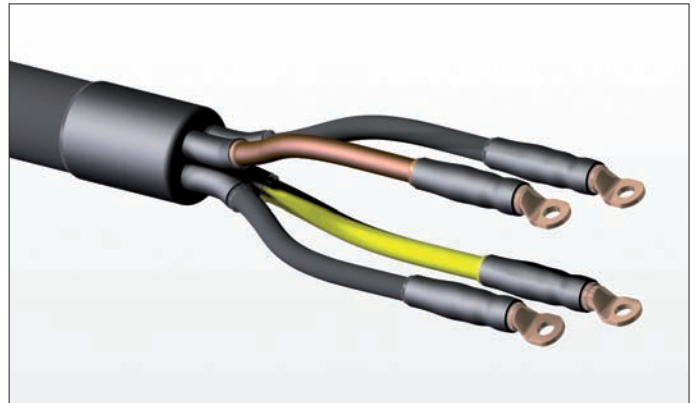

Voltage range	Cable crosssection [mm ²]	Number of core	Type of cable joint	Index
0,6/1kV	16-25	4	TLP-CG4 16-25	WGE0AG4FG0001
	35-70	4	TLP-CG4 35-70	WGE0AG4HJ0001
	95-150	4	TLP-CG4 95-120	WGE0AG4KM0001
	150-240	4	TLP-CG4 150-240	WGE0AA4MO0001

Sets don't contain cable lugs. For termination cables with the use of crimping lugs.

MEDIUM VOLTAGE CABLE TERMINATIONS

Indoor cable terminations for single-core unscreened polymer insulated cables with drain tapes

3,6/6kV



- Application:** designed for termination cables of type: NYY, NAYY, YKY, YAKY.
- Technical information:** connection of drain tapes is done with the use of earthing set. Insulation and filling mastic used as anti-moisture barrier. Heat shrink phase marker resistant to creeping current and environmental conditions is shrunk on insulation.
- Properties of the terminations:**
- resistant to hard environmental conditions,
 - insulation protection prevent from superficial discharges occurring,
 - resistant to UV radiation,
 - short assembling time thanks to simple construction.

Voltage range	Cable cross-section [mm ²]	Type of cable termination	Length [mm]	Index
3,6/6kV and 6/6kV	25-70	THP-I-6-CX1/300 25-70	300	WGEIBI1GJ3001
		THP-I-6-CX1/450 25-70	450	WGEIBI1GJ4501
	95-120	THP-I-6-CX1/300 95-120	300	WGEIBI1KL3001
		THP-I-6-CX1/450 95-120	450	WGEIBI1KL4501
	150-240	THP-I-6-CX1/300 150-240	300	WGEIBI1MO3001
		THP-I-6-CX1/450 150-240	450	WGEIBI1MO4501

Termination sets enable making of three single-phase terminations, are supplied with earthing kit, sets don't contain cable terminals.

Indoor cable terminations for single-core unscreened polymer insulated cables with copper wire screen

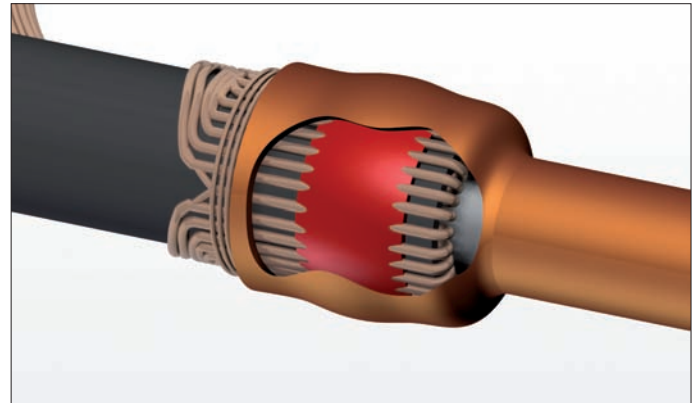
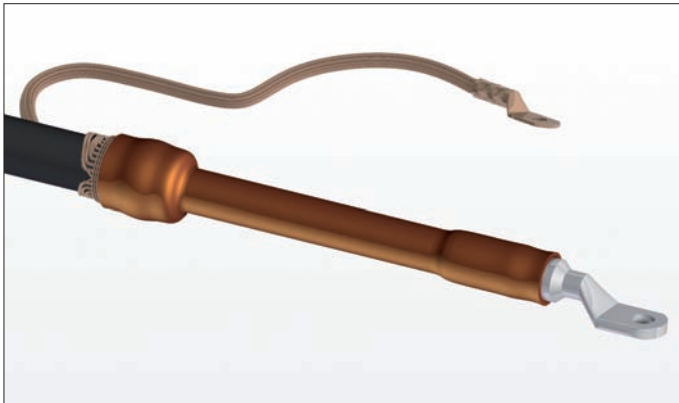

3,6/6kV

Application:
designed for termination cables of type: NYY, NAYY, YKY, YAKY.

Technical information: insulation and filling mastic used as anti-moisture barrier.
Heat shrink phase marker resistant to creeping current and environmental conditions shrunk on insulation.

- Properties of the terminations:**
- resistant to hard environmental conditions,
 - insulation protection prevent from superficial discharges occurring,
 - resistant to UV radiation,
 - short assembling time thanks to simple construction.
 - high electrical and mechanical resistance.

Voltage range	Cable cross-section [mm ²]	Type of cable termination	Length [mm]	Index
3,6/6kV and 6/6kV	25-70	THP-I-6-CXd1/450 25-70	450	WGEIBD1GJ4501
		THP-I-6-CXd1/650 25-70	650	WGEIBD1GJ6501
	95-120	THP-I-6-CXd1/450 95-120	450	WGEIBD1KL4501
		THP-I-6-CXd1/650 95-120	650	WGEIBD1KL6501
	150-240	THP-I-6-CXd1/450 150-240	450	WGEIBD1MO4501
		THP-I-6-CXd1/650 150-240	650	WGEIBD1MO6501

Termination sets enable making of three single-phase terminations, are supplied with earthing kit, sets don't contain cable terminals.

Indoor cable terminations for 3-core unscreened polymer insulated cables with drain tapes

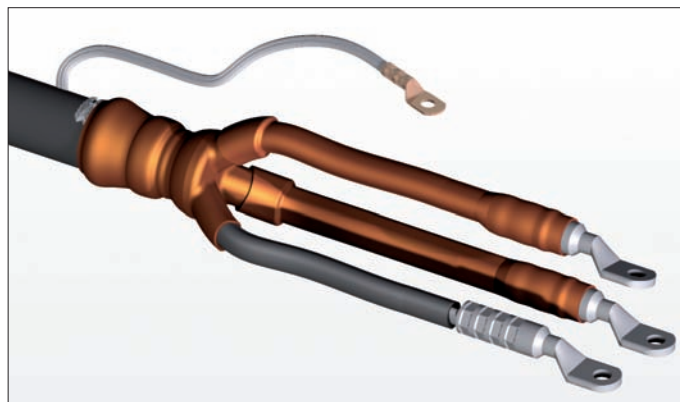
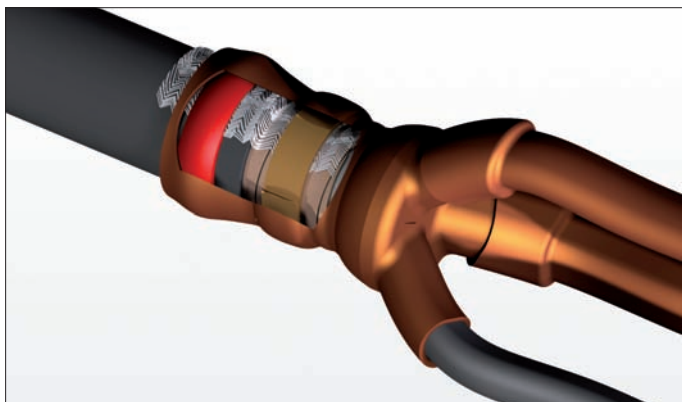

3,6/6kV

Application:
designed for termination cables of type: NYY, NAYY, YKY, YAKY.

Technical information: Connection of drain tapes is done with the use of earthing set. Heat shrink breakout boot with adhesive protects the place of cores' outlet. Additional anti-moisture barrier is guaranteed by insulation and filling mastic. Heat shrink phase marker resistant to creeping current and environmental conditions is shrunk on particular cores' insulation.

- Properties of the terminations:**
- resistant to hard environmental conditions,
 - insulation protection prevent from superficial discharges occurring,
 - resistant to UV radiation,
 - high electrical and mechanical resistance,
 - anti-moisture barrier in the form of heat shrink breakout boot and insulation mastics.

Voltage range	Cable cross-section [mm ²]	Type of cable termination	Length [mm]	Index
3,6/6kV and 6/6kV	25-50	THP-I-6-CX3/300 25-50	300	WGEIBI3GI3001
		THP-I-6-CX3/650 25-50	650	WGEIBI3GI6501
		THP-I-6-CX3/800 25-50	800	WGEIBI3GI8001
	70-120	THP-I-6-CX3/300 70-120	300	WGEIBI3JL3001
		THP-I-6-CX3/650 70-120	650	WGEIBI3JL6501
		THP-I-6-CX3/800 70-120	800	WGEIBI3JL8001
	150-240	THP-I-6-CX3/300 150-240	300	WGEIBI3MO3001
		THP-I-6-CX3/650 150-240	650	WGEIBI3MO6501
		THP-I-6-CX3/800 150-240	800	WGEIBI3MO8001

Termination sets made as three-phase are supplied with earthing kit, sets don't contain cable terminals.

Indoor cable terminations for 3-core unscreened polymer insulated cables with copper wire screen

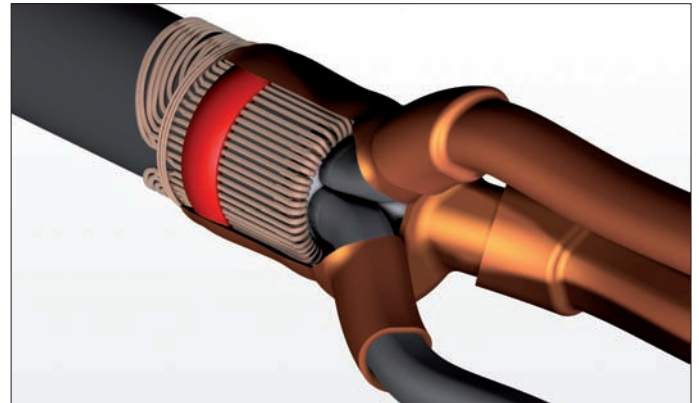
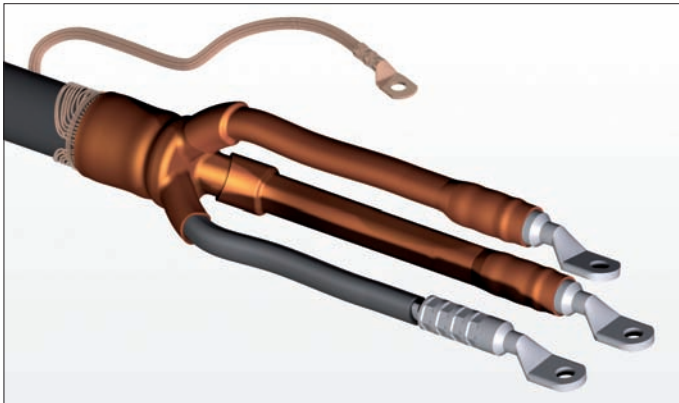

3,6/6kV

Application:
designed for termination cables of type: NYY, NAYY, YKY, YAKY.

Technical information:

Connection of drain tapes is done with the use of earthing set. Heat shrink breakout boot with adhesive protects the place of cores' outlet. Additional anti-moisture barrier is guaranteed by insulation and filling mastic. Heat shrink phase marker resistant to creeping current and environmental conditions is shrunk on particular cores' insulation.

Properties of the terminations:

- resistant to hard environmental conditions,
- insulation protection prevent from superficial discharges occurring,
- resistant to UV radiation,
- high electrical and mechanical resistance,
- anti-moisture barrier in the form of heat shrink breakout boot and insulation mastics.

Voltage range	Cable cross-section [mm ²]	Type of cable termination	Length [mm]	Index
3,6/6kV and 6/6kV	25-50	THP-I-6-CXd3/300 25-50	300	WGEIBD3GI3001
		THP-I-6-CXd3/650 25-50	650	WGEIBD3GI6501
		THP-I-6-CXd3/800 25-50	800	WGEIBD3GI8001
	70-120	THP-I-6-CXd3/300 70-120	300	WGEIBD3JL3001
		THP-I-6-CXd3/650 70-120	650	WGEIBD3JL6501
		THP-I-6-CXd3/800 70-120	800	WGEIBD3JL8001
	150-240	THP-I-6-CXd3/300 150-240	300	WGEIBD3MO3001
		THP-I-6-CXd3/650 150-240	650	WGEIBD3MO6501
		THP-I-6-CXd3/800 150-240	800	WGEIBD3MO8001

Termination sets made as three-phase, sets don't contain cable terminals.

Outdoor cable terminations for 3-core unscreened polymer insulated cables with drain tapes

3,6/6kV

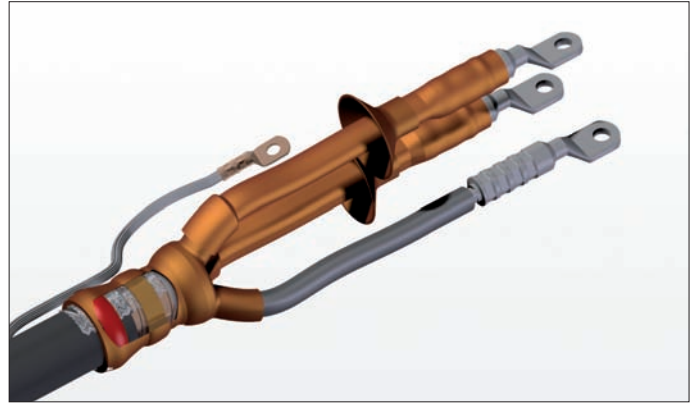

Application: designed for termination cables of type: NYY, NAYY, YKY, YAKY.

Technical information: connection of drain tapes is done with the use of earthing set. Heat shrink breakout boot with adhesive protects the place of cores' outlet. Additional anti-moisture barrier is guaranteed by insulation and filling mastic. Heat shrink phase marker resistant to creeping current and environmental conditions is shrunk on particular cores' insulation together shrink sheds.

- Properties of the terminations:**
- resistant to hard environmental conditions,
 - insulation protection prevent from superficial discharges occurring,
 - resistant to UV radiation,
 - high electrical and mechanical resistance,
 - anti-moisture barrier in the form of heat shrink breakout boot and insulation mastics.

Voltage range	Cable cross-section [mm ²]	Type of cable termination	Length [mm]	Index
3,6/6kV and 6/6kV	25-50	THP-N-6-CX3/450 25-50	450	WGENBI3GI4501
		THP-N-6-CX3/650 25-50	650	WGENBI3GI6501
	70-120	THP-N-6-CX3/450 70-120	450	WGENBI3JL4501
		THP-N-6-CX3/650 70-120	650	WGENBI3JL6501
	150-240	THP-N-6-CX3/450 150-240	450	WGENBI3MO4501
		THP-N-6-CX3/650 150-240	650	WGENBI3MO6501

Termination sets made as three-phase are supplied with earthing kit, sets don't contain cable terminals. Meant for leakproof cable lugs.

Outdoor cable terminations for 3-core unscreened polymer insulated cables with copper wire screen

3,6/6kV

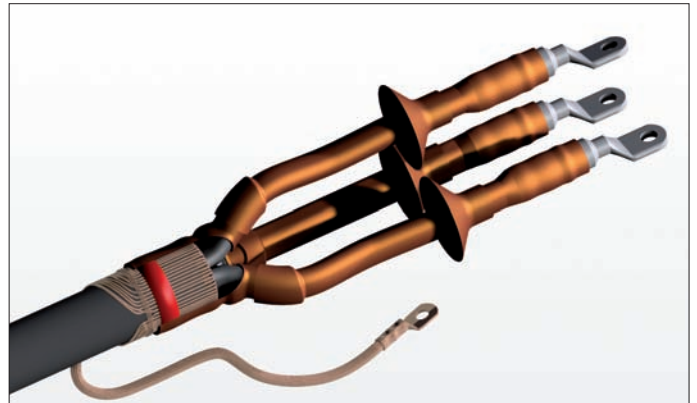

Application: designed for termination cables of type: NYY, NYY, YKY, YAKY.

Technical information: heat shrink breakout boot with adhesive protects the place of cores' outlet. Additional anti-moisture barrier is guaranteed by insulation and filling mastic. Heat shrink phase marker resistant to creeping current and environmental conditions is shrunk on particular cores' insulation together shrink sheds.

- Properties of the terminations:**
- resistant to hard environmental conditions,
 - insulation protection prevent from superficial discharges occurring,
 - resistant to UV radiation,
 - high electrical and mechanical resistance,
 - anti-moisture barrier in the form of heat shrink breakout boot and insulation mastics.

Voltage range	Cable cross-section [mm ²]	Type of cable termination	Length [mm]	Index
3,6/6kV and 6/6kV	25-50	THP-N-6-CXd3/450 25-50	450	WGENBD3GI4501
		THP-N-6-CXd3/650 25-50	650	WGENBD3GI6501
	70-120	THP-N-6-CXd3/450 70-120	450	WGENBD3JL4501
		THP-N-6-CXd3/650 70-120	650	WGENBD3JL6501
	150-240	THP-N-6-CXd3/450 150-240	450	WGENBD3MO4501
		THP-N-6-CXd3/650 150-240	650	WGENBD3MO6501

Termination sets made as three-phase, sets don't contain cable terminals.
Meant for leakproof cable lugs.

Indoor cable terminations for 3-core unscreened polymer insulated and armoured cables with drain tapes

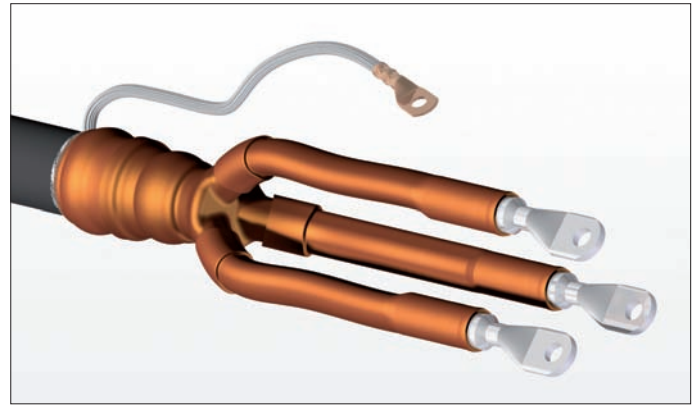
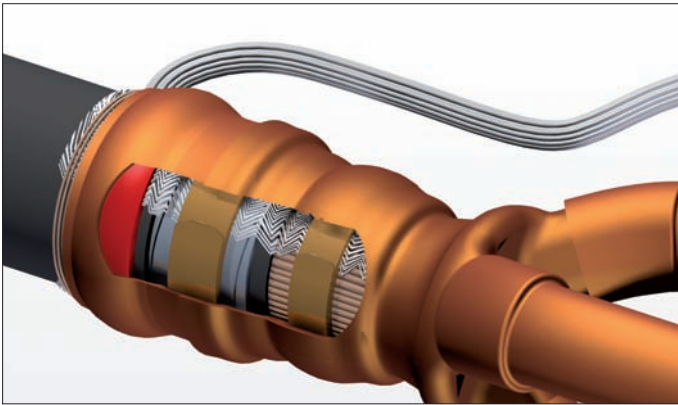

3,6/6kV

Application: designed for termination cables of type: N(A)YCY, N(A)YCWY, YAKYFty, YKYFty, YAKYFpy, YKYFpy, YAKYFoy, YKYFoy.

Technical information:

connection of drain tapes is done with the use of earthing set. Heat shrink breakout boot with adhesive protects the place of cores' outlet. Additional anti-moisture barrier is guaranteed by insulation and filling mastic. Heat shrink phase marker resistant to creeping current and environmental conditions is shrunk on particular cores' insulation.

Properties of the terminations:

- spring clips connect easily and safely the earthing tape with cable's armour,
- resistant to hard environmental conditions,
- insulation protection prevent from superficial discharges occurring,
- resistant to UV radiation,
- high electrical and mechanical resistance,
- anti-moisture barrier in the form of heat shrink breakout boot and insulation mastics.

Voltage range	Cable cross-section [mm ²]	Type of cable termination	Length [mm]	Index
3,6/6kV and 6/6kV	25-50	THP-I-6-CA3/300 25-50	300	WGEIBA3GI3001
		THP-I-6-CA3/650 25-50	650	WGEIBA3GI6501
		THP-I-6-CA3/800 25-50	800	WGEIBA3GI8001
	70-120	THP-I-6-CA3/300 70-120	300	WGEIBA3JL3001
		THP-I-6-CA3/650 70-120	650	WGEIBA3JL6501
		THP-I-6-CA3/800 70-120	800	WGEIBA3JL8001
	150-240	THP-I-6-CA3/300 150-240	300	WGEIBA3MO3001
		THP-I-6-CA3/650 150-240	650	WGEIBA3MO6501
		THP-I-6-CA3/800 150-240	800	WGEIBA3MO8001

Termination sets made as three-phase are supplied with earthing kit, sets don't contain cable terminals.

Outdoor cable terminations for 3-core unscreened polymer insulated and armoured cables with drain tapes or wire screen

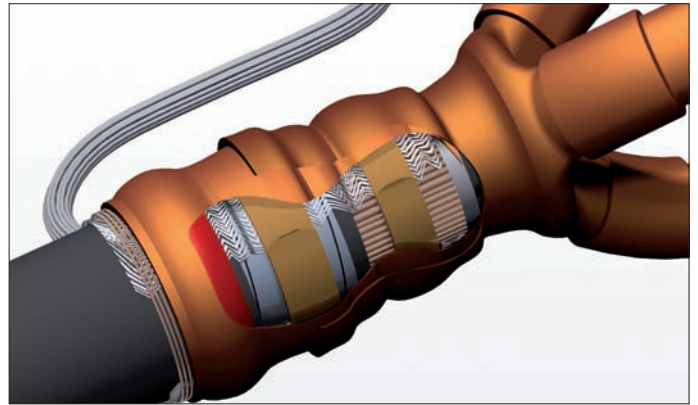
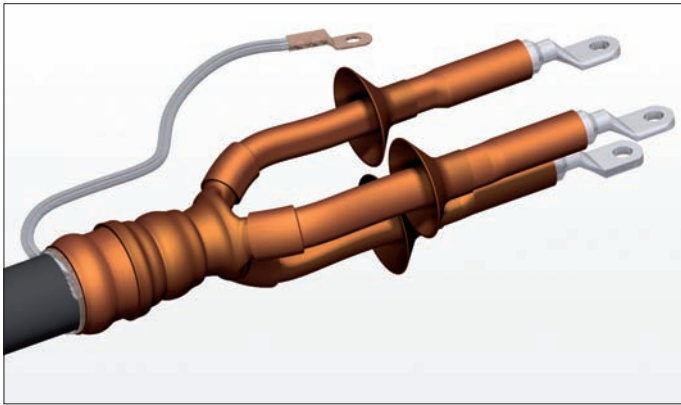

3,6/6kV

Application: designed for termination cables of type: N(A)YCY, N(A)YCWY, YAKYFty, YKYFty, YAKYFpy, YKYFpy, YAKYFoy, YKYFoy.

Technical information:

connection of drain tapes is done with the use of earthing set. Heat shrink breakout boot with adhesive protects the place of cores' outlet. Additional anti-moisture barrier is guaranteed by insulation and filling mastic. Heat shrink phase marker resistant to creeping current and environmental conditions is shrunk on particular cores' insulation.

Properties of the terminations:

- spring clips connect easily and safely the earthing tape with cable's armour,
- resistant to hard environmental conditions,
- insulation protection prevent from superficial discharges occurring,
- resistant to UV radiation,
- high electrical and mechanical resistance,
- anti-moisture barrier in the form of heat shrink breakout boot and insulation mastics.

Voltage range	Cable cross-section [mm ²]	Type of cable termination	Length [mm]	Index
3,6/6kV and 6/6kV	25-50	THP-N-6-CA3/300 25-50	300	WGENBA3GI3001
		THP-N-6-CA3/650 25-50	650	WGENBA3GI6501
		THP-N-6-CA3/800 25-50	800	WGENBA3GI8001
	70-120	THP-N-6-CA3/300 70-120	300	WGENBA3JL3001
		THP-N-6-CA3/650 70-120	650	WGENBA3JL6501
		THP-N-6-CA3/800 70-120	800	WGENBA3JL8001
	150-240	THP-N-6-CA3/300 150-240	300	WGENBA3MO3001
		THP-N-6-CA3/650 150-240	650	WGENBA3MO6501
		THP-N-6-CA3/800 150-240	800	WGENBA3MO8001

Termination sets made as three-phase are supplied with earthing kit, sets don't contain cable terminals. Meant for leakproof cable lugs.

Indoor cable termination for 1-core unscreened armoured polymer insulated traction cables

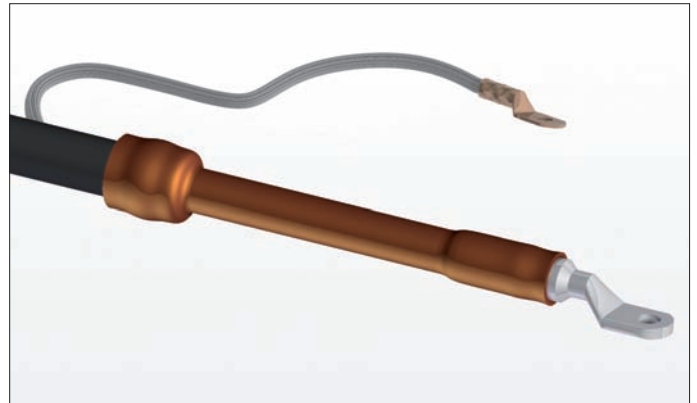

3,6/6kV
6/6kV

Application:
designed for termination cables of type: Y(A)KYFty, Y(A)KYFpy, Y(A)KYFoy.

Technical information: Connection of return wires is made using the included earthing unit. Sealing compounds used as anti-moisture barrier. A heat-shrink phase marker resistant to creeping current and environmental conditions is shrunk on the insulation.

Properties of the terminations:

- resistant to harsh environmental conditions,
- insulation protection prevents the occurrence of gliding discharges,
- UV resistant,
- short assembly time thanks to the simple construction,
- high electrical and mechanical strength.

Voltage range	Cable cross-section [mm ²]	Type of cable termination	Length [mm]	Index
3,6/6kV 6/6kV	500	THP-I-6-CT1 500	600	WGEIBT1S00001

Cable termination sets made as 3-phase cables include earthing unit, terminals not included.

Outdoor cable termination for 1-core unscreened armoured polymer insulated traction cables

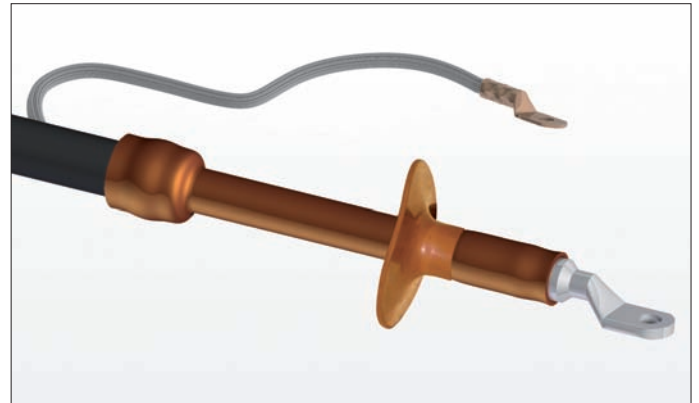

3,6/6kV
6/6kV

Application:
designed for termination cables of type: Y(A)KYFty, Y(A)KYFpy, Y(A)KYFoy.

Technical information: Connection of return wires is made using the included earthing unit. Sealing compounds used as anti-moisture barrier. A heat-shrink phase marker with cable entry seal are shrunk on the insulation. Resistant to creeping current and environmental conditions.

Properties of the terminations:

- resistant to harsh environmental conditions,
- insulation protection prevents the occurrence of gliding discharges,
- UV resistant,
- short assembly time thanks to the simple construction,
- high electrical and mechanical strength.

Voltage range	Cable cross-section [mm ²]	Type of cable termination	Length [mm]	Index
3,6/6kV 6/6kV	500	THP-N-6-CT1 500	600	WGENBT1S00001

One 1-phase cable termination can be made using the set, terminals are not included.

Indoor cable terminations for single-core screened polymer insulated cables with copper wire screen

Application: designed for termination cables of type: N(A)2XS(2)Y, N(A)2XS(F)(L)(2)Y, YH(A)KXS, XUH(A)KXS, XH(A)KXS, X(RU)H(A)KXS.

Technical information: the sets are based on heat shrink technology. They contain: phase marker resistant to creeping current, stress control mastic and tubing which are applied for controlling of the electrical field, insulation mastic preventing from moisture penetration. Terminations are additionally equipped with double-layer mastic used in drain wires' outlet and increasing termination tightness even in situations of multiple warming up and cooling processes in case of breaking work.

Properties of the terminations:

- resistant to hard environmental conditions,
- for cables with cross-sections up to 400 mm² (concerns terminations with screw lugs),
- in case of terminations with screw terminals they limit the number of tools necessary for the assembling,
- heat shrink tubes applied in the termination create insulation protection against superficial discharges,
- resistant to UV radiation,
- full protection against moisture penetration,
- high electrical and mechanical resistance,
- short assembling time thanks to simple construction and attached installation guide,

Positive technical approving issued by Institute of Power Engineering in conformity with requirements of norms PN-90/E-06401 i PN-HD 629.1 S2:2006.

6/10kV
8,7/15kV
12/20kV



Voltage range	Cable cross-section [mm ²]	Type of cable termination	Length [mm]	Index
6/10kV	50-95	THP-I-10-CXd1 50-95 (S)	450	WGEICD1IK00S1
	120-240	THP-I-10-CXd1 120-240 (S)	450	WGEICD1LO00S1
	240-400	THP-I-10-CXd1 240-400 (S)	450	WGEICD1OR00S1
8,7/15kV	35-95	THP-I-15-CXd1 35-95 (S)	450	WGEIDD1HK00S1
	95-240	THP-I-15-CXd1 95-240 (S)	450	WGEIDD1KO00S1
	185-400	THP-I-15-CXd1 185-400 (S)	450	WGEIDD1NR00S1
12/20kV	50-150	THP-I-20-CXd1 50-150 (S)	450	WGEIED1HM00S1
	95-240	THP-I-20-CXd1 95-240 (S)	450	WGEIED1JO00S1
	185-400	THP-I-20-CXd1 185-400 (S)	450	WGEIED1NR00S1

Termination sets enable making of three single-phase terminations, supplied with screw connectors.

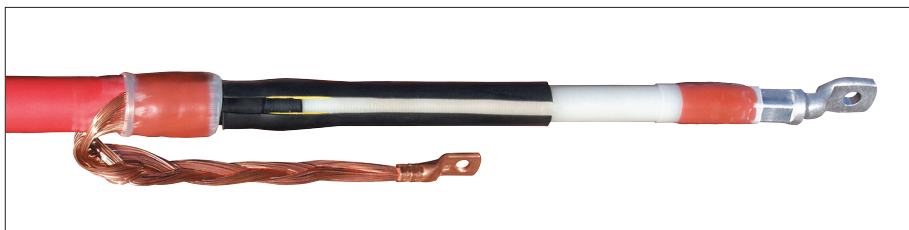

Voltage range	Cable cross-section [mm ²]	Type of cable termination	Length [mm]	Index
6/10kV	35-95	THP-I-10-CXd1 35-95	450	WGEICD1HK0001
	95-240	THP-I-10-CXd1 95-240	450	WGEICD1KO0001
8,7/15kV	35-95	THP-I-15-CXd1 35-95	450	WGEIDD1HK0001
	95-240	THP-I-15-CXd1 95-240	450	WGEIDD1KO0001
12/20kV	35-95	THP-I-20-CXd1 35-95	450	WGEIED1HK0001
	70-240	THP-I-20-CXd1 70-240	450	WGEIED1JO0001

Termination sets enable making of three single-phase terminations. They are meant for termination cables with the use of compression terminals, sets don't contain terminals.

Outdoor cable terminations for single-core screened polymer insulated cables with copper wire screen

Application: designed for termination cables of type: N(A)2XS(2)Y, N(A)2XS(F)(L)(2)Y, YH(A)KXS, XUH(A)KXS, XH(A)KXS, X(RU)H(A)KXS.

Technical information: the construction of the outdoor termination is similar to indoor termination. Additionally depending on the voltage level heat shrink sheds are shrunk on insulation tube. They prevent from creeping current.

Properties of the terminations:

- resistant to hard environmental conditions,
 - for cables with cross-sections up to 400 mm² (concerns terminations with screw lugs) ,
 - in case of terminations with screw terminals they limit the number of tools necessary for the assembling,
 - heat shrink tubes applied in the termination create insulation protection against superficial discharges,
 - resistant to UV radiation,
 - full protection against moisture penetration,
 - high electrical and mechanical resistance,
 - short assembling time thanks to simple construction and attached installation guide,
- Positive technical approving issued by Institute of Power Engineering in conformity with requirements of norms PN-90/E-06401 i PN-HD 629.1 S2:2006.

6/10kV
8,7/15kV
12/20kV

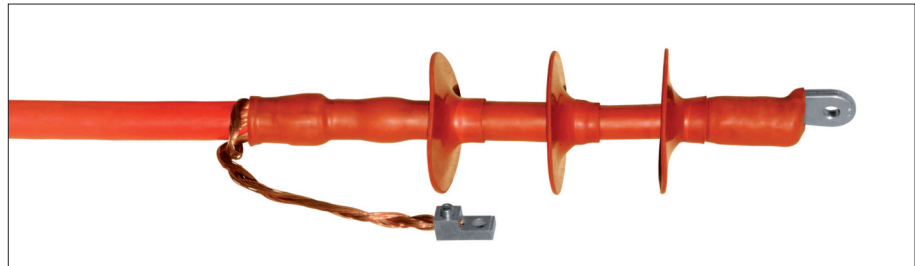

Voltage range	Cable cross-section [mm ²]	Type of cable termination	Length [mm]	Index
6/10kV	50-95	THP-N-10-CXd1 50-95 (S)	450	WGENCD1IK00S1
	120-240	THP-N-10-CXd1 120-240 (S)	450	WGENCD1LO00S1
	240-400	THP-N-10-CXd1 240-400 (S)	450	WGENCD1OR00S1
8,7/15kV	35-95	THP-N-15-CXd1 35-95 (S)	450	WGENDD1HK00S1
	95-240	THP-N-15-CXd1 95-240 (S)	450	WGENDD1KO00S1
	185-400	THP-N-15-CXd1 185-400 (S)	450	WGENDD1NR00S1
12/20kV	50-150	THP-N-20-CXd1 50-150 (S)	450	WGENED1HM00S1
	95-240	THP-N-20-CXd1 95-240 (S)	450	WGENED1JO00S1
	185-400	THP-N-20-CXd1 185-400 (S)	450	WGENED1NR00S1

Termination sets enable making of three single-phase terminations, supplied with screw lugs.

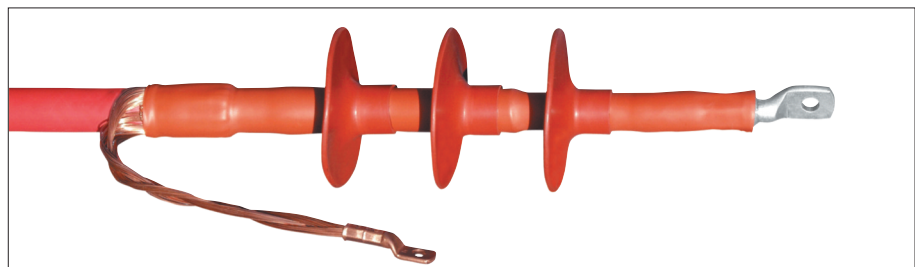

Voltage range	Cable cross-section [mm ²]	Type of cable termination	Length [mm]	Index
6/10kV	35-95	THP-N-10-CXd1 35-95	450	WGENCD1HK0001
	95-240	THP-N-10-CXd1 95-240	450	WGENCD1KO0001
8,7/15kV	35-95	THP-N-15-CXd1 35-95	450	WGENDD1HK0001
	95-240	THP-N-15-CXd1 95-240	450	WGENDD1KO0001
12/20kV	35-95	THP-N-20-CXd1 35-95	450	WGENED1HK0001
	70-240	THP-N-20-CXd1 70-240	450	WGENED1JO0001

Termination sets enable making of three single-phase terminations They are meant for termination cables with the use of compression terminals, sets don't contain terminals. Meant for leakproof cable lugs.

Indoor cable terminations for 3-core saturated paper insulated and armoured cables with common metal sheath

3,6/6kV
6/10kV



Application: designed for termination cables of type: N(A)KRA, N(A)KFY, N(A)KRY, AKnFtA, AKnFpA, AKnFt, AKnFp, AKnFty, AKnFpy, KnFtA, KnFpA, KnFt, KnFp.

Technical information: insulation of particular cable's cores is made with the use of transparent heat shrink tubes resistant to cable saturant. Heat shrink breakout boot with adhesive protects the place of cores' outlet and metal sheath termination. Connection of sheath and metal armour is made with the use of earthing kit. Cable's cores insulation is strengthened by heat shrink phase markers L1, L2 and L3 which are made of material resistant to creeping current. Additional anti-moisture barrier is guaranteed by insulation mastic. Minimal termination length - 300 mm.

- Properties of the terminations:**
- spring clips connect easily and safely the earthing tape with cable's armour,
 - resistant to hard environmental conditions,
 - high electrical and mechanical resistance,
 - resistant to UV radiation,
 - anti-moisture barrier in the form of heat shrink breakout boot and insulation and filling mastic,
 - designed and made of materials resistant to cable saturant.

Voltage range	Cable cross-section [mm ²]	Type of cable termination	Length [mm]	Index
3,6/6kV	25-50	THP-I-6-CF3/300 25-50	300	WGEIBF3GI3001
		THP-I-6-CF3/650 25-50	650	WGEIBF3GI6501
		THP-I-6-CF3/800 25-50	800	WGEIBF3GI8001
	70-120	THP-I-6-CF3/300 70-120	300	WGEIBF3JL3001
		THP-I-6-CF3/650 70-120	650	WGEIBF3JL6501
		THP-I-6-CF3/800 70-120	800	WGEIBF3JL8001
	150-240	THP-I-6-CF3/300 150-240	300	WGEIBF3MO3001
		THP-I-6-CF3/650 150-240	650	WGEIBF3MO6501
		THP-I-6-CF3/800 150-240	800	WGEIBF3MO8001
6/10kV	35-50	THP-I-10-CF3/450 35-50	450	WGEICF3HI4501
		THP-I-10-CF3/650 35-50	650	WGEICF3HI6501
		THP-I-10-CF3/800 35-50	800	WGEICF3HI8001
	70-120	THP-I-10-CF3/450 70-120	450	WGEICF3JL4501
		THP-I-10-CF3/650 70-120	650	WGEICF3JL6501
		THP-I-10-CF3/800 70-120	800	WGEICF3JL8001
	150-240	THP-I-10-CF3/450 150-240	450	WGEICF3MO4501
		THP-I-10-CF3/650 150-240	650	WGEICF3MO6501
		THP-I-10-CF3/800 150-240	800	WGEICF3MO8001

Termination sets made as three-phase are supplied with earthing kit, sets don't contain cable cable terminals. It recommends the use of leakproof cable lugs.

Outdoor cable terminations for 3-core saturated paper insulated and armoured cables with common metal sheath

3,6/6kV
6/10kV

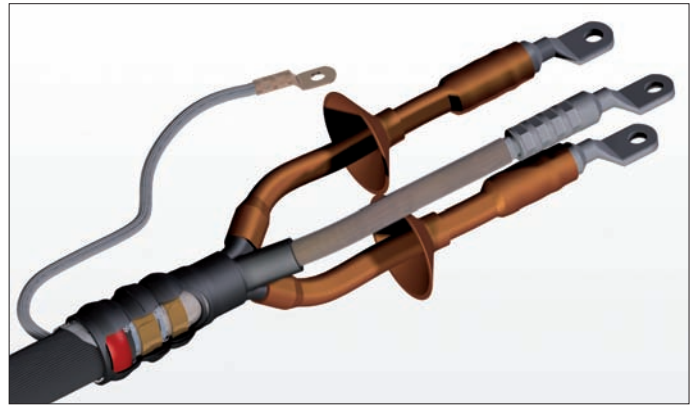

Application: designed for termination cables of type: N(A)KRA, N(A)KFY, N(A)KRY, AKnFtA, AKnFpA, AKnFt, AKnFp, AKnFty, AKnFpy, KnFtA, KnFpA, KnFt, KnFp.

Technical information: analogous construction like in case of indoor terminations. Additionally heat shrink sheds preventing from creeping current occurrence are shrunk on phase markers. Minimal termination length - 450 mm.

- Properties of the terminations:**
- spring clips connect easily and safely the earthing tape with cable's armour,
 - resistant to hard environmental conditions,
 - high electrical and mechanical resistance,
 - resistant to UV radiation,
 - anti-moisture barrier in the form of heat shrink breakout boot and insulation and filling mastic,
 - designed and made of materials resistant to cable saturant.

Voltage range	Cable cross-section [mm ²]	Type of cable termination	Length [mm]	Index
3,6/6kV	25-50	THP-N-6-CF3/450 25-50	450	WGENBF3GI4501
		THP-N-6-CF3/650 25-50	650	WGENBF3GI6501
		THP-N-6-CF3/800 25-50	800	WGENBF3GI8001
	70-120	THP-N-6-CF3/450 70-120	450	WGENBF3JL4501
		THP-N-6-CF3/650 70-120	650	WGENBF3JL6501
		THP-N-6-CF3/800 70-120	800	WGENBF3JL8001
	150-240	THP-N-6-CF3/450 150-240	450	WGENBF3MO4501
		THP-N-6-CF3/650 150-240	650	WGENBF3MO6501
		THP-N-6-CF3/800 150-240	800	WGENBF3MO8001
6/10kV	35-50	THP-N-10-CF3/450 35-50	450	WGENCF3HI4501
		THP-N-10-CF3/650 35-50	650	WGENCF3HI6501
		THP-N-10-CF3/800 35-50	800	WGENCF3HI8001
	70-120	THP-N-10-CF3/450 70-120	450	WGENCF3JL4501
		THP-N-10-CF3/650 70-120	650	WGENCF3JL6501
		THP-N-10-CF3/800 70-120	800	WGENCF3JL8001
	150-240	THP-N-10-CF3/450 150-240	450	WGENCF3MO4501
		THP-N-10-CF3/650 150-240	650	WGENCF3MO6501
		THP-N-10-CF3/800 150-240	800	WGENCF3MO8001

Termination sets made as three-phase are supplied with earthing kit, sets don't contain cable terminals. Meant for leakproof cable lugs.

Indoor cable terminations for 3-core screened saturated paper insulated and armoured cables with common metal sheath

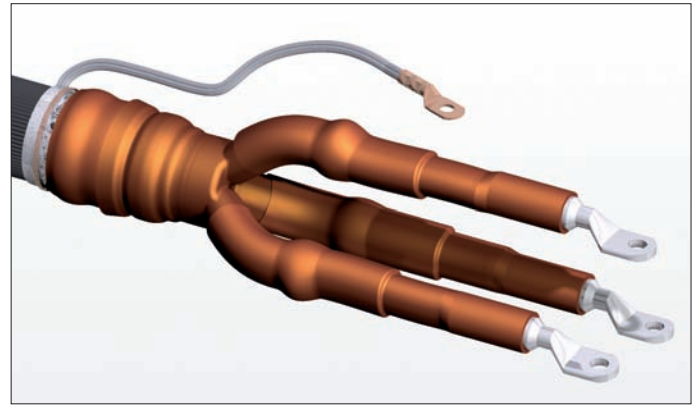
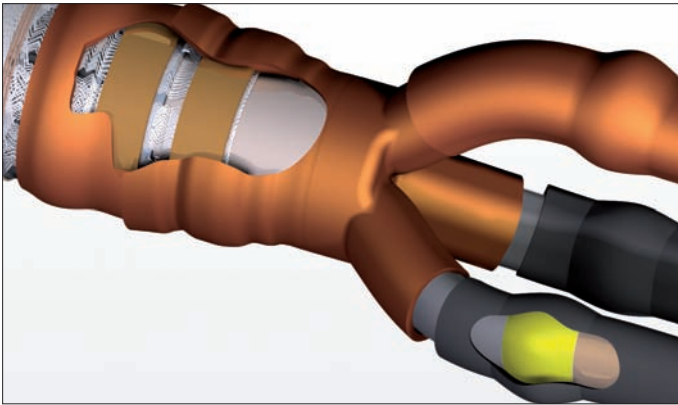

8,7/15kV
12/20kV

Application:
designed for termination cables of type: N(A)HKBA, H(A)KnFtA, H(A)KnF(t, p)y, H(A)Kny.

Technical information: insulation of the particular cable's cores isolation is made with the use of transparent tubes. Stress control mastic are applied for controlling of individual cores' screens and collective screen under the metal sheath. Heat shrink phase markers and breakout boot are resistant to creeping current. Connection of armour with metal sheath is done with the use of earthing kit.

Properties of the terminations:

- universal application for cables of two voltage levels: 8,7/15kV and 12/20kV,
 - resistant to hard environmental conditions,
 - in case of terminations with screw connectors they limit the number of tools necessary for the assembling,
 - resistant to UV radiation,
 - full protection against moisture penetration,
 - high electrical and mechanical resistance.
- Positive technical approving issued by Institute of Power Engineering in conformity with requirements of norm PN-HD 629.2 S2:2006.

Voltage range	Cable cross-section [mm ²]	Type of cable termination	Length [mm]*	Index
8,7/15kV i 12/20kV	35-150	THP-I-20-CF3/450 35-150	450	WGEIEF3HM4501
	95-240	THP-I-20-CF3/450 95-240	450	WGEIEF3KO4501
	35-150	THP-I-20-CF3/1200 35-150	1200	WGEIEF3HM1201
	95-240	THP-I-20-CF3/1200 95-240	1200	WGEIEF3KO1201

* capability of production terminations of lengths 650, 800.
Termination sets are meant for terminating cables with the use of compression terminals (sets don't contain terminals).
It recommends the use of leakproof terminals.
Set contains earthing kit.

Voltage range	Cable cross-section [mm ²]	Type of cable termination	Length [mm]*	Index
8,7/15kV i 12/20kV	50-150	THP-I-20-CF3/450 50-150 (S)	450	WGEIEF3HM45S1
	95-240	THP-I-20-CF3/450 95-240 (S)	450	WGEIEF3KO45S1
	50-150	THP-I-20-CF3/1200 50-150 (S)	1200	WGEIEF3HM12S1
	95-240	THP-I-20-CF3/1200 95-240 (S)	1200	WGEIEF3KO12S1

* capability of production terminations of lengths 650, 800.
Termination sets are supplied with screw terminals.
Set contains earthing kit.

Outdoor cable terminations for 3-core screened saturated paper insulated and armoured cables with common metal sheath

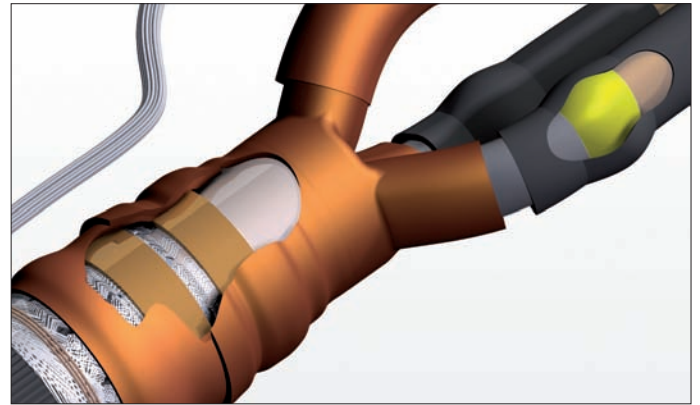
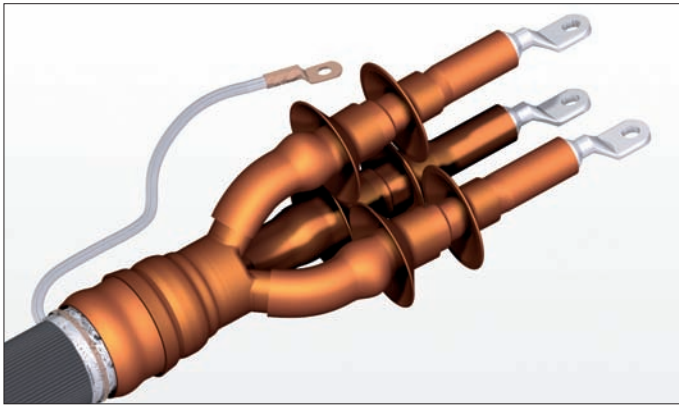

8,7/15kV
12/20kV

Application:
designed for termination cables of type: N(A)HKBA, H(A)KnFtA, H(A)KnF(t, p)y, H(A)Kny.

Technical information: analogous construction like in case of indoor terminations. Additionally heat shrink sheds preventing from creeping current occurrence are shrunk on phase markers.

Properties of the terminations:

- universal application for cables of two voltage levels: 8,7/15kV and 12/20kV,
- resistant to hard environmental conditions,
- in case of terminations with screw connectors they limit the number of tools necessary for the assembling,
- resistant to UV radiation,
- full protection against moisture penetration,
- high electrical and mechanical resistance.

Positive technical approving issued by Institute of Power Engineering in conformity with requirements of norm PPN-HD 629.2 S2:2006.

Voltage range	Cable cross-section [mm ²]	Type of cable termination	Length [mm]*	Index
8,7/15kV i 12/20kV	35-150	THP-N-20-CF3/450 35-150	450	WGENEF3HM4501
	95-240	THP-N-20-CF3/450 95-240	450	WGENEF3KO4501
	35-150	THP-N-20-CF3/1200 35-150	1200	WGENEF3HM1201
	95-240	THP-N-20-CF3/1200 95-240	1200	WGENEF3KO1201

* capability of production terminations of lengths 650, 800.

Termination sets are meant for terminating cables with the use of compression terminals (sets don't contain terminals).

It recommends the use of leakproof terminals.

Set contains earthing kit.

Voltage range	Cable cross-section [mm ²]	Type of cable termination	Length [mm]*	Index
8,7/15kV i 12/20kV	50-150	THP-N-20-CF3/450 50-150 (S)	450	WGENEF3HM45S1
	95-240	THP-N-20-CF3/450 95-240 (S)	450	WGENEF3KO45S1
	50-150	THP-N-20-CF3/1200 50-150 (S)	1200	WGENEF3HM12S1
	95-240	THP-N-20-CF3/1200 95-240 (S)	1200	WGENEF3KO12S1

* capability of production terminations of lengths 650, 800.

Termination sets are supplied with screw terminals.

Set contains earthing kit.

Indoor cable terminations for screened rubber insulated wires with three service cores and three protection cores

3,6/6kV

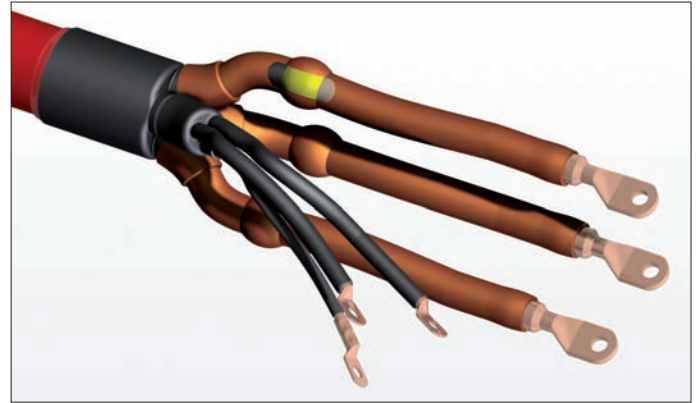

- Application:** designed for termination cables of type: NTSCGEWOE, OGb, OGc, OnGckgż-G, OnGbckgż-G.
- Technical information:** wire's cores outlet is protected with heat shrink breakout boots with adhesive (4-core and 3-core - for three protection cores). Additional anti-moisture barrier is guaranteed by insulation mastic. Terminations of semi-conducting screens are wrapped round by stress control mastic. Heat shrink phase marker resistant to creeping current and environmental conditions is shrunk on particular cores' insulation.
- Properties of the terminations:**
- supplied with stress control mastic for regulating of the electrical tension distribution on conducting screens' terminations,
 - resistant to hard environmental conditions,
 - full protection against moisture penetration,
 - insulation protection prevents from creeping current,
 - resistant to UV radiation.

Voltage range	Cable cross-section [mm ²]	Type of cable termination	Length [mm]	Index
3,6/6kV	3x16 + 3x16/3	THP-I-6-CG4/450 3x16 + 3x16/3	450	WGGIBGAFF4501
	3x25 + 3x16/3	THP-I-6-CG4/450 3x25 + 3x16/3	450	WGGIBGAGF4501
	3x35 + 3x16/3	THP-I-6-CG4/450 3x35 + 3x16/3	450	WGGIBGAHF4502
	3x50 + 3x25/3	THP-I-6-CG4/450 3x50 + 3x25/3	450	WGGIBGAI4501
	3x70 + 3x35/3	THP-I-6-CG4/450 3x70 + 3x35/3	450	WGGIBGAJH4501
	3x95 + 3x50/3	THP-I-6-CG4/450 3x95 + 3x50/3	450	WGGIBGAKI4502
	3x120 + 3x70/3	THP-I-6-CG4/450 3x120 + 3x70/3	450	WGGIBGALJ4501

Sets don't contain cable terminals. Terminations of non standard lengths are available on request.

Indoor cable terminations for screened rubber insulated wires with three service cores and three protection cores

6/10kV

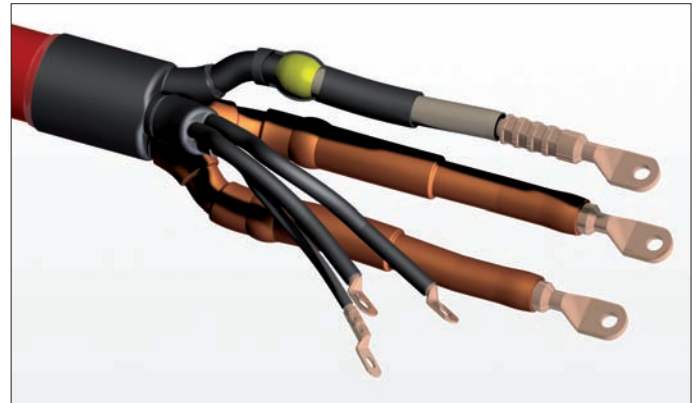

Application: designed for termination mining wires of type: NTSCGEWOE, OnGcekgz-G (S), OnGcekgz-G (Z), OnGcrekgz-G (S), OnGcrekgz-G (Z) 6/10kV.

Technical information: heat shrink breakout boots protect the cores' outlet. Mastic used for additional anti-moisture protection. Stress control tubing and mastic are applied for controlling of the electrical field on the screen's termination. Heat shrink phase marker resistant to creeping current and environmental conditions is shrunk on particular cores' insulation.

Properties of the terminations:

- supplied with stress control tubing and mastic for regulating of the electrical tension distribution on semiconducting screens' terminations,
- resistant to hard environmental conditions,
- full protection against moisture penetration,
- phase markers resistant to creeping current.

Positive technical approving issued by Institute of Power Engineering in conformity with requirements of norm PN-HD 629.1 S2:2006

Voltage range	Cable cross-section [mm ²]	Type of cable termination	Length [mm]	Index
6/10kV	3x16 + 3x16/3	THP-I-10-CG4/800 3x16 + 3x16/3	800	WGGICGAFF8001
	3x25 + 3x16/3	THP-I-10-CG4/800 3x25 + 3x16/3	800	WGGICGAGF8001
	3x35 + 3x16/3	THP-I-10-CG4/800 3x35 + 3x16/3	800	WGGICGAHF8001
	3x50 + 3x25/3	THP-I-10-CG4/800 3x50 + 3x25/3	800	WGGICGAI8001
	3x70 + 3x35/3	THP-I-10-CG4/800 3x70 + 3x35/3	800	WGGICGAIJ8001
	3x95 + 3x50/3	THP-I-10-CG4/800 3x95 + 3x50/3	800	WGGICGAKI8001
	3x120 + 3x70/3	THP-I-10-CG4/800 3x120 + 3x70/3	800	WGGICGALJ8001
	3x150 + 3x70/3	THP-I-10-CG4/800 3x150 + 3x70/3	800	WGGICGAMJ8001
	3x185 + 3x95/3	THP-I-10-CG4/800 3x185 + 3x95/3	800	WGGICGANK8001

Sets don't contain cable terminals.

Outdoor cable terminations for screened rubber insulated cables with three service cores and three protection cores

6/10kV

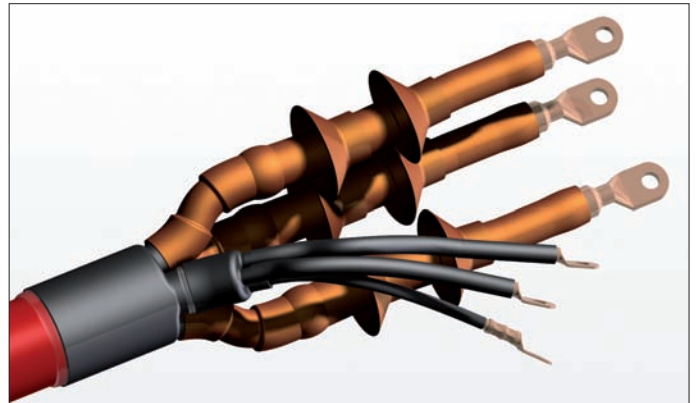

Application: designed for termination mining cables of type: NTSCGEWOE, OnGcekgz-G (S), OnGcekgz-G (Z), OnGcrekgz-G (S), OnGcrekgz-G (Z) 6/10kV.

Technical information: analogous construction like in case of indoor terminations. Additionally heat shrink sheds preventing from creeping current occurrence are shrunk on phase markers (two on one phase).

Properties of the terminations:

- supplied with stress control tubing and mastic for regulating of the electrical tension distribution on semiconducting screens' terminations,
- resistant to hard environmental conditions,
- full protection against moisture penetration,
- phase markers resistant to creeping current.

Positive technical approving issued by Institute of Power Engineering in conformity with requirements of norm PN-HD 629.1 S2:2006.

Voltage range	Cable cross-section [mm ²]	Type of cable termination	Length [mm]	Index
6/10kV	3x16 + 3x16/3	THP-N-10-CG4/800 3x16 + 3x16/3	800	WGGNCGAFF8001
	3x25 + 3x16/3	THP-N-10-CG4/800 3x25 + 3x16/3	800	WGGNCGAGF8001
	3x35 + 3x16/3	THP-N-10-CG4/800 3x35 + 3x16/3	800	WGGNCGAHF8001
	3x50 + 3x25/3	THP-N-10-CG4/800 3x50 + 3x25/3	800	WGGNCGAIG8001
	3x70 + 3x35/3	THP-N-10-CG4/800 3x70 + 3x35/3	800	WGGNCGAJG8001
	3x95 + 3x50/3	THP-N-10-CG4/800 3x95 + 3x50/3	800	WGGNCGAKI8001
	3x120 + 3x70/3	THP-N-10-CG4/800 3x120 + 3x70/3	800	WGGNCGALJ8001
	3x150 + 3x70/3	THP-N-10-CG4/800 3x150 + 3x70/3	800	WGGNCGAMJ8001
	3x185 + 3x95/3	THP-N-10-CG4/800 3x185 + 3x95/3	800	WGGNCGANK8001

Sets don't contain cable terminals.
Meant for leakproof cable lugs.

Indoor cable terminals for 3-core unscreened armoured polymer insulated power and mining cables with flame-retardant coating

3,6/6kV

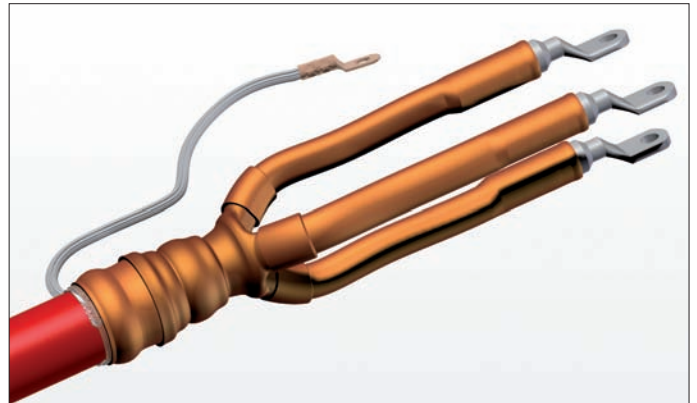

Application:

designed for termination cables of type: YKGYFtyn, YKGYFtlyn, YKGYFoy, YKGYFpyn.

Technical information:

connection of drain wires and armour is made with the use of earthing kit. Termination sets are supplied with phase markers, flame-retardant breakout boot and bigger quantity of insulation mastic.

Properties of the terminations:

- spring clips connect easily and safely the earthing tape with cable's armour,
- insulation protection prevent from superficial discharges occurring ,
- resistant to hard environmental conditions,
- self-extinguishing,
- high electrical and mechanical resistance,
- full protection against moisture penetration thanks to applied heat shrink breakout boot and insulation mastic.

Voltage range	Cable cross-section [mm ²]	Type of cable termination	Length [mm]	Index
3,6/6kV i 6/6kV	25-50	THPG-I-6-CA3/300 25-50	300	WGGIBA3GI3001
		THPG-I-6-CA3/450 25-50	450	WGGIBA3GI4501
		THPG-I-6-CA3/650 25-50	650	WGGIBA3GI6501
	70-120	THPG-I-6-CA3/300 70-120	300	WGGIBA3JL3001
		THPG-I-6-CA3/450 70-120	450	WGGIBA3JL4501
		THPG-I-6-CA3/650 70-120	650	WGGIBA3JL6501
	150-240	THPG-I-6-CA3/300 150-240	300	WGGIBA3MO3001
		THPG-I-6-CA3/450 150-240	450	WGGIBA3MO4501
		THPG-I-6-CA3/650 150-240	650	WGGIBA3MO6501

Termination sets made as three-phase are supplied with earthing kit, sets don't contain cable terminals.

EARTHING SETS

Earthing sets - paper insulated cables - type PEK



Application:

designed for earthing the metal sheath (lead or aluminum) and steel armoring of cables with saturated paper insulation and metal sheath, armoured, of types: N(A)KRA, N(A)KFY, N(A)KRY, AKnFtA, AKnFpA, AKnFt, AKnFp, AKnFty, AKnFpy.

Type of earthing sets	Index	Cable crosssection [mm ²]			
		3,6/6kV	6/10kV	8,7/15kV	12/20kV
PEK-20-CF3 16-35	WGE0EF3FHZU01	16 ÷ 95	16 ÷ 50	-	-
PEK-20-CF3 35-95	WGE0EF3IKZU01	70 ÷ 240	35 ÷ 120	35 ÷ 95	35 ÷ 70
PEK-20-CF3 120-240	WGE0EF3LOZU01	120 ÷ 240	70 ÷ 240	35 ÷ 240	35 ÷ 240

Earthing sets - polymer insulated cables - type PEK



Application:

designed for earthing of drain wires and armour of cables type: N(A)2XS(2)Y, N(A)2XS(F)(L)(2)Y, YH(A)KXS, XUH(A)KXS, XH(A)KXS, X(RU)H(A)KXS.

Type of earthing sets	Index	Cable crosssection [mm ²]	
		8,7/15kV	12/20kV
PEK-20-CX1 35-95	WGE0EF3HKZU01	50 ÷ 95	35 ÷ 95
PEK-20-CX1 70-240	WGE0EF3JOZU01	95 ÷ 240	70 ÷ 240

Kit allows to earth three single-core cables.

Aluminium thin-walled cable terminals - type 2 KAM

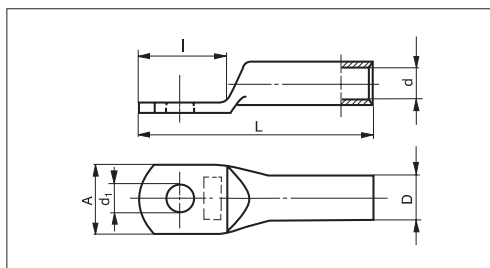
**Application**

For the termination of round aluminum cores and sector - shaped conductors, voltage up to 1KV. They increase the safety and life of connection.

Assembling

In order to make the durable assembling of terminal, it should be pressed by using the suitable press (in case of sector cores - the core should be first formed round).

Technical data

Material: aluminum pipe and bars drawing in the recrystallizing condition of EN AW-1050 A grade PN-EN 573-3

Core cross section [mm ²]	Type of terminals	Index	Packing [pcs.]	Cumulative packing [pcs.]	Dimensions [mm]					
					D	d	d ₁	L	I	A
16	2 KAM 16/6	WOKAA01600006A1	50	800	9,2	5,2	6,5	50	18	16
16	2 KAM 16/8	WOKAA01600008A1	50	800	9,2	5,2	8,5	50	18	16
16	2 KAM 16/10	WOKAA01600010A1	50	800	9,2	5,2	11	50	20	19
25	2 KAM 25/8	WOKAA02500008A1	50	500	10,4	6,4	8,5	58	22	20
25	2 KAM 25/10	WOKAA02500010A1	50	500	10,4	6,4	11	60	22	20
25	2 KAM 25/12	WOKAA02500012A1	50	500	10,4	6,4	13	60	26	24
35	2 KAM 35/8.	WOKAA03500008A1	50	400	12	7,6	8,5	62	22	20
35	2 KAM 35/10	WOKAA03500010A1	50	400	12	7,6	11	62	22	20
35	2 KAM 35/12	WOKAA03500012A1	50	400	12	7,6	13	62	22	20
50	2 KAM 50/8	WOKAA05000008A1	20	240	14	9,2	8,5	74	26	24
50	2 KAM 50/10	WOKAA05000010A1	20	240	14	9,2	11	73	26	24
50	2 KAM 50/12	WOKAA05000012A1	20	240	14	9,2	13	74	26	24
70	2 KAM 70/8	WOKAA07000008A1	20	200	15,6	10,6	8,5	77	26	26
70	2 KAM 70/10	WOKAA07000010A1	20	200	15,6	10,6	11	77	26	26
70	2 KAM 70/12	WOKAA07000012A1	20	200	15,6	10,6	13	77	26	26
95	2 KAM 95/8	WOKAA09500008A1	20	120	18	12,8	8,5	90	26	26
95	2 KAM 95/10	WOKAA09500010A1	20	120	18	12,8	11	90	26	26
95	2 KAM 95/12	WOKAA09500012A1	20	120	18	12,8	13	91	26	26
95	2 KAM 95/16	WOKAA09500016A1	20	120	18	12,8	17	98	34	26
120	2 KAM 120/8	WOKAA12000008A1	10	100	19,7	14,3	8,5	104	30	28
120	2 KAM 120/10	WOKAA12000010A1	10	100	19,7	14,3	11	104	30	28
120	2 KAM 120/12	WOKAA12000012A1	10	100	19,7	14,3	13	104	30	28
120	2 KAM 120/16	WOKAA12000016A1	10	100	19,7	14,3	17	108	34	28
150	2 KAM 150/10	WOKAA15000010A1	10	80	22	16,2	11	118	34	34
150	2 KAM 150/12	WOKAA15000012A1	10	80	22	16,2	13	118	34	34
150	2 KAM 150/16	WOKAA15000016A1	10	80	22	16,2	17	118	34	34
185	2 KAM 185/10	WOKAA18500010A1	10	60	24	17,8	11	130	40	38
185	2 KAM 185/12	WOKAA18500012A1	10	60	24	17,8	13	129	40	38
185	2 KAM 185/16	WOKAA18500016A1	10	60	24	17,8	17	130	40	38
240	2 KAM 240/10	WOKAA24000010A1	10	40	28,2	20,2	11	134	40	40
240	2 KAM 240/12	WOKAA24000012A1	10	40	28,2	20,2	13	133	40	40
240	2 KAM 240/16	WOKAA24000016A1	10	40	28,2	20,2	17	132	40	40

Aluminium cable terminals acc. to DIN standard, voltage up to 30kV - type DKA

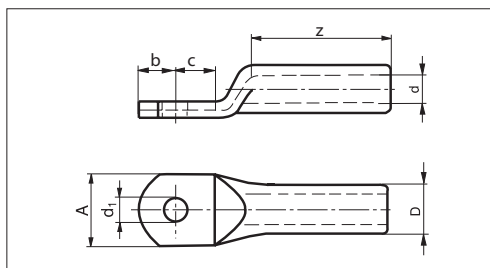

- Application** For the termination of round aluminum cores and sector - shaped conductors, voltage up to 30KV. They increase the safety and life of connection.
- Assembling** In order to make the durable assembling of terminal, it should be pressed by using the suitable press (in case of sector cores - the core should be first formed round).
- Technical data** Accordance with DIN 46 329 standard concerns the tubular part. DIN standard 46 329 does not cover cross-sections 16 mm² and 625 mm².
Material: aluminum pipe and bars drawing in the recrystallizing condition of EN AW-1050 A grade PN-EN 573-3. DKA terminals are protected inside by technical contact paste improved the connection quality.
For the assurance of suitable plasticity of contact paste, the DKA terminals are packed separately one piece in one folie sack and next all together.

Core cross section [mm ²]	Type of terminals	Index	Packing [pcs.]	Cumulative packing [pcs.]	Dimensions [mm]							
rm, sm	se				D	d	d ₁	A	b	c	z	
16	25	DKA 16/6.	WOKCA0160000601	50	300	12	5,6	6,5	18	8	15,5	30
16	25	DKA 16/8	WOKCA0160000801	50	300	12	5,6	8,5	18	10	15,5	30
16	25	DKA 16/10	WOKCA0160001001	50	300	12	5,6	10,5	18	12	15,5	30
25	35	DKA 25/8.	WOKCA0250000801	50	250	12	6,8	8,5	18	10	15,5	30
25	35	DKA 25/10	WOKCA0250001001	50	250	12	6,8	10,5	18	12	15,5	30
35	50	DKA 35/8	WOKCA0350000801	50	200	14	8	8,5	21	10	15,5	42
35	50	DKA 35/10.	WOKCA0350001001	50	200	14	8	10,5	21	12	15,5	42
35	50	DKA 35/12	WOKCA0350001201	50	200	14	8	13	21	13	15,5	42
50	70	DKA 50/8	WOKCA0500000801	20	140	16	9,8	8,5	25	10	15,5	42
50	70	DKA 50/10.	WOKCA0500001001	20	140	16	9,8	10,5	25	12	15,5	42
50	70	DKA 50/12	WOKCA0500001201	20	140	16	9,8	13	25	13	15,5	42
70	95	DKA 70/8	WOKCA0700000801	20	100	18,5	11,2	8,5	28	10	15,5	52
70	95	DKA 70/10	WOKCA0700001001	20	100	18,5	11,2	10,5	28	12	15,5	52
70	95	DKA 70/12.	WOKCA0700001201	20	100	18,5	11,2	13	28	13	15,5	52
95	120	DKA 95/10	WOKCA0950001001	20	60	22	13,2	10,5	32	12	15,5	56
95	120	DKA 95/12.	WOKCA0950001201	20	60	22	13,2	13	32	13	15,5	56
95	120	DKA 95/16	WOKCA0950001601	20	60	22	13,2	17	32	16	15,5	56
120	150	DKA 120/10	WOKCA1200001001	10	60	23	14,7	10,5	32	12	20	56
120	150	DKA 120/12.	WOKCA1200001201	10	60	23	14,7	13	32	13	20	56
120	150	DKA 120/16	WOKCA1200001601	10	60	23	14,7	17	32	16	20	56
150	185	DKA 150/10	WOKCA1500001001	10	40	25	16,3	10,5	35	12	20	60
150	185	DKA 150/12	WOKCA1500001201	10	40	25	16,3	13	35	13	20	60
150	185	DKA 150/16.	WOKCA1500001601	10	40	25	16,3	17	35	16	20	60
185	240	DKA 185/12	WOKCA1850001201	10	30	28,5	18,3	13	40	13	20	60
185	240	DKA 185/16.	WOKCA1850001601	10	30	28,5	18,3	17	40	16	20	60
240	300	DKA 240/12	WOKCA2400001201	10	30	32	21	13	45	13	24	70
240	300	DKA 240/16.	WOKCA2400001601	10	30	32	21	17	45	16	24	70
300	-	DKA 300/12	WOKCA3000001201	10	20	34	23,3	13	49	13	24	70
300	-	DKA 300/16.	WOKCA3000001601	10	20	34	23,3	17	49	16	24	70
300	-	DKA 300/20	WOKCA3000002001	10	20	34	23,3	21	49	20	24	70
500	-	DKA 500/12	WOKCA5000001201	4	12	44	29	13	71	20	24	79
500	-	DKA 500/16	WOKCA5000001601	4	12	44	29	17	71	20	24	79
500	-	DKA 500/20	WOKCA5000002001	4	12	44	29	21	71	20	24	79
625	-	DKA 625/12	WOKCA6250001201	4	12	52	35	13	71	20	24	95
625	-	DKA 625/16	WOKCA6250001601	4	12	52	35	17	71	20	24	95
625	-	DKA 625/20	WOKCA6250002001	4	12	52	35	21	71	20	24	95

rm - round bunched core, sm - segmental bunched core, se - segmental solid core.

Aluminium leakproof terminals acc. to DIN standard, voltage up to 30kV - type DKAP

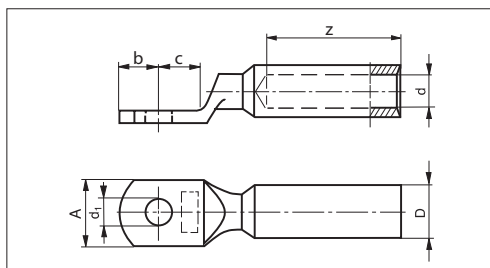
**Application**

For the termination of round aluminum cores and sector - shaped conductors, voltage up to 30KV. For indoor and outdoor use. They increase the safety and life of connection.

Assembling

In order to make the durable assembling of terminal, it should be pressed by using the suitable press (in case of sector cores - the core should be first formed round).

Technical data

Accordance with DIN 46329 standard concerns the tubular part. DIN standard 46329 does not cover cross-sections 16 mm². Material: aluminum bars drawing in the recrystallizing condition of EN AW-1050 A grade PN-EN 573-3.

Terminals with the partition. Inside terminals are protected inside by technical contact paste improved the connection quality.

For the assurance of suitable plasticity of contact paste, the terminals are packed separately one piece in one folie sack and next all together.

Core cross section [mm ²]		Type of terminals	Index	Packing [pcs.]	Cumulative packing [pcs.]	Dimensions [mm]						
rm, sm	se					D	d	d ₁	A	b	c	z
16	25	DKAP 16/6.	WOKDA0160000601	50	800	12	5,6	6,5	25	8	15,5	30
16	25	DKAP 16/8	WOKDA0160000801	50	800	12	5,6	8,5	25	10	15,5	30
25	35	DKAP 25/8.	WOKDA0250000801	50	500	12	6,8	8,5	25	10	15,5	30
25	35	DKAP 25/10	WOKDA0250001001	50	500	12	6,8	10,5	25	12	15,5	30
35	50	DKAP 35/10.	WOKDA0350001001	50	300	14	8	10,5	25	12	15,5	42
35	50	DKAP 35/12	WOKDA0350001201	50	300	14	8	13	25	13	15,5	42
50	70	DKAP 50/10.	WOKDA0500001001	20	240	16	9,8	10,5	25	12	15,5	42
50	70	DKAP 50/12	WOKDA0500001201	20	240	16	9,8	13	25	13	15,5	42
70	95	DKAP 70/10	WOKDA0700001001	20	200	18,5	11,2	10,5	25	12	15,5	52
70	95	DKAP 70/12.	WOKDA0700001201	20	200	18,5	11,2	13	25	13	15,5	52
95	120	DKAP 95/12.	WOKDA0950001201	20	140	22	13,2	13	25	13	15,5	56
95	120	DKAP 95/16	WOKDA0950001601	20	140	22	13,2	17	25	16	15,5	56
120	150	DKAP 120/12.	WOKDA1200001201	10	100	23	14,7	13	30	13	20	56
120	150	DKAP 120/16	WOKDA1200001601	10	100	23	14,7	17	30	16	20	56
150	185	DKAP 150/12.	WOKDA1500001201	10	80	25	16,3	13	30	13	20	60
150	185	DKAP 150/16.	WOKDA1500001601	10	80	25	16,3	17	30	16	20	60
185	240	DKAP 185/12	WOKDA1850001201	10	50	28,5	18,3	13	30	13	20	60
185	240	DKAP 185/16.	WOKDA1850001601	10	50	28,5	18,3	17	30	16	20	60
240	300	DKAP 240/12	WOKDA2400001201	10	50	32	21	13	38	13	24	70
240	300	DKAP 240/16.	WOKDA2400001601	10	50	32	21	17	38	16	24	70
300	-	DKAP 300/12	WOKDA3000001201	10	50	34	23,3	13	38	13	24	70
300	-	DKAP 300/16.	WOKDA3000001601	10	50	34	23,3	17	38	16	24	70
300	-	DKAP 300/20	WOKDA3000002001	10	50	34	23,3	21	38	20	24	70

rm - round bunched core, sm - segmental bunched core, se - segmental solid core.

Aluminium thin-walled ferrules - type 2 ZA

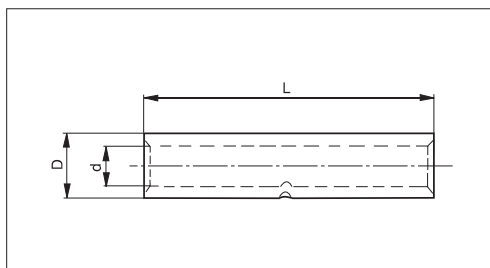
**Application**

For connection of round aluminum cores and sector - shaped conductors, can be use for 10 ÷ 30kV voltage. They increase the safety and life of connection.

Assembling

In order to make the durable assembling of ferrule, it should be pressed by using the suitable press (in case of sector cores - the core should be first formed round).

Technical data

Material: aluminum pipe and bars drawing in the recrystallizing condition of EN AW-1050
Agrade PN-EN 573-3

Core cross section [mm ²]	Type of ferrules	Index	Packing [pcs.]	Cumulative packing [pcs.]	Dimensions [mm]		
					D	d	L
16	2 ZA 16	WOZAA01600000A1	50	800	9,2	5,2	50
25	2 ZA 25	WOZAA02500000A1	50	500	10,4	6,4	58
35	2 ZA 35	WOZAA03500000A1	50	300	12,0	7,6	63
50	2 ZA 50	WOZAA05000000A1	20	240	14,0	9,2	73
70	2 ZA 70	WOZAA07000000A1	20	200	15,6	10,6	76
95	2 ZA 95	WOZAA09500000A1	20	140	18,0	12,8	92
120	2 ZA 120	WOZAA12000000A1	10	100	19,7	14,3	105
150	2 ZA 150	WOZAA15000000A1	10	80	22,0	16,2	120
185	2 ZA 185	WOZAA18500000A1	10	60	24,0	17,8	132
240	2 ZA 240	WOZAA24000000A1	10	40	28,2	20,2	136

Aluminium ferrules acc. to DIN standard - type DZA

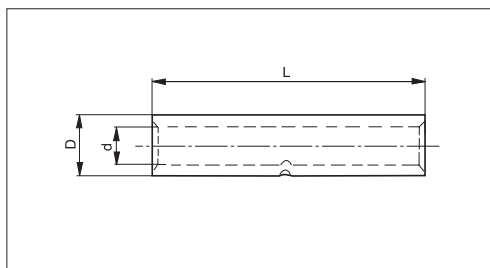

- Application** For connection of round aluminum cores and sector - shaped conductors, voltage up to $10 \div 30$ kV. They increase the safety and life of connection.
- Assembling** In order to make the durable assembling of ferrule, it should be pressed by using the suitable press (in case of sector cores - the core should be first formed round).
- Technical data** Full accordance with DIN 46267-2 standards. DIN standard 46 267-2 does not cover cross-sections 16 mm^2 and 625 mm^2 .
Material: aluminum pipe in the recrystallizing condition of EN AW-1050 Agrade PN-EN 573-3.
Special contact paste applied inside ferrules improve the quality of the connection.
For the assurance of suitable plasticity of contact paste, the ferrules are packed separately one piece in one folie sack.

Core cross section [mm ²]		Type of ferrules	Index	Packing [pcs.]	Cumulative packing [pcs.]	Dimensions [mm]		
rm, sm	se					D	d	L
16	25	DZA 16	WOZCA0160000001	50	350	12,0	5,6	60
25	35	DZA 25	WOZCA0250000001	50	300	12,0	6,8	70
35	50	DZA 35	WOZCA0350000001	50	200	14,0	8,0	85
50	70	DZA 50	WOZCA0500000001	20	160	16,0	9,8	85
70	95	DZA 70	WOZCA0700000001	20	100	18,5	11,2	105
95	120	DZA 95	WOZCA0950000001	20	80	22,0	13,2	105
120	150	DZA 120	WOZCA1200000001	10	80	23,0	14,7	105
150	185	DZA 150	WOZCA1500000001	10	50	25,0	16,3	125
185	240	DZA 185	WOZCA1850000001	10	40	28,5	18,3	125
240	300	DZA 240	WOZCA2400000001	10	30	32,0	21,0	145
300	-	DZA 300	WOZCA3000000001	10	20	34,0	23,3	145
500	-	DZA 500	WOZCA5000000001	4	12	44,0	29,0	210
625	-	DZA 625	WOZCA6250000001	4	12	52,0	35,0	210

rm - round bunched core, sm - segmental bunched core, se - segmental solid core.

Aluminium ferrules with the partition acc. to DIN standard - type DZAP

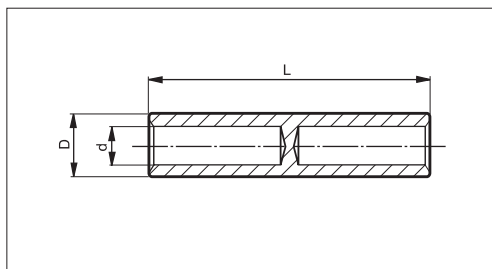
**Application**

For connection of round aluminum cores and sector - shaped conductors, voltage up to 10kV. They increase the safety and life of connection. They have an air-tight compartment which allows using them for cables with impregnant-rich insulation and prevents moisture against spreading.

Assembling

In order to make the durable assembling of ferrule, it should be pressed by using the suitable press (in case of sector cores - the core should be first formed round).

Technical data

Standard diameters DIN 46267 part.2. DIN standard DIN 46267 part.2 does not cover cross-sections 16 mm².

Material: aluminum bars drawing in the recrystallizing condition of EN AW-1050 Agrade PN-EN 573-3. With the leakproof partition. Special contact paste applied inside ferrules improve the quality of the connection.

For the assurance of suitable plasticity of contact paste, the ferrules are packed separately one piece in one folie sack

Core cross section [mm ²]		Type of ferrules	Index	Packing [pcs.]	Cumulative packing [pcs.]	Dimension [mm]		
rm, sm	se					D	d	L
16	25	DZAP 16	WOZDA0160000001	4	48	12,0	5,6	60
25	35	DZAP 25	WOZDA0250000001	4	48	12,0	6,8	70
35	50	DZAP 35	WOZDA0350000001	4	48	14,0	8,0	85
50	70	DZAP 50	WOZDA0500000001	4	20	16,0	9,8	85
70	95	DZAP 70	WOZDA0700000001	4	20	18,5	11,2	105
95	120	DZAP 95	WOZDA0950000001	4	20	22,0	13,2	105
120	150	DZAP 120	WOZDA1200000001	4	12	23,0	14,7	105
150	185	DZAP 150	WOZDA1500000001	4	12	25,0	16,3	125
185	240	DZAP 185	WOZDA1850000001	4	12	28,5	18,3	125
240	300	DZAP 240	WOZDA2400000001	4	12	32,0	21,0	145
300	-	DZAP 300	WOZDA3000000001	4	12	34	23,3	160

rm - round bunched core, sm - segmental bunched core, se - segmental solid core.

Aluminium reducing ferrules acc. to DIN standard - type DZRA

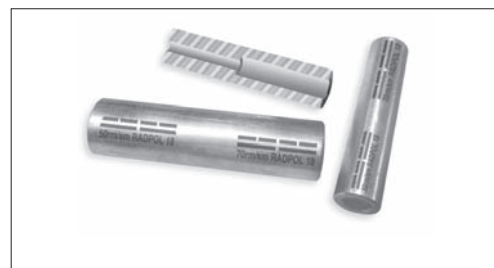
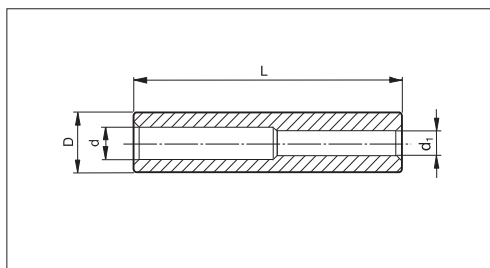
**Application**

For connection of round aluminum cores and sector - shaped conductors, voltage up to 6kV.
They increase the safety and life of connection.

Assembling

In order to make the durable assembling of ferrule, it should be pressed by using the suitable press (in case of sector cores - the core should be first formed round).

Technical data

Standard diameters DIN 46267 part.2. DIN standard DIN 46267 part.2 does not cover cross-sections 16 mm².

Material: aluminum bars drawing in the recrystallizing condition of EN AW-1050 Agrade PN-EN 573-3.
Special contact paste applied inside ferrules improve the quality of the connection.

For the assurance of suitable plasticity of contact paste, the ferrules are packed separately one piece in one folie sack.

Core cross section [mm ²]	Type of ferrules	Index	Packing [pcs.]	Cumulative packing [pcs.]	Dimensions [mm]				
					input	output	D	d	d ₁
16	10	DZRA 16 / 10	WOZCA0160100001	4	48	12,0	5,6	4,9	65
25	10	DZRA 25 / 10	WOZCA0250100001	4	48	12,0	6,8	4,9	65
25	16	DZRA 25 / 16	WOZCA0250160001	4	48	12,0	6,8	5,6	65
35	25	DZRA 35 / 25	WOZCA0350250001	4	48	14,0	8,0	6,8	90
50	25	DZRA 50 / 25	WOZCA0500250001	4	20	16,0	9,8	6,8	90
50	35	DZRA 50 / 35	WOZCA0500350001	4	20	16,0	9,8	8,0	90
70	16	DZRA 70 / 16	WOZCA0700160001	4	20	18,5	11,2	5,6	110
70	25	DZRA 70 / 25	WOZCA0700250001	4	20	18,5	11,2	6,8	110
70	35	DZRA 70 / 35	WOZCA0700350001	4	20	18,5	11,2	8,0	110
70	50	DZRA 70 / 50	WOZCA0700500001	4	20	18,5	11,2	9,8	110
95	25	DZRA 95 / 25	WOZCA0950250001	4	20	22,0	13,2	6,8	110
95	35	DZRA 95 / 35	WOZCA0950350001	4	20	22,0	13,2	8,0	110
95	50	DZRA 95 / 50	WOZCA0950500001	4	20	22,0	13,2	9,8	110
95	70	DZRA 95 / 70	WOZCA0950700001	4	20	22,0	13,2	11,2	110
120	25	DZRA 120 / 25	WOZCA1200250001	4	12	23,0	14,7	6,8	110
120	35	DZRA 120 / 35	WOZCA1200350001	4	12	23,0	14,7	8,0	110
120	50	DZRA 120 / 50	WOZCA1200500001	4	12	23,0	14,7	9,8	110
120	70	DZRA 120 / 70	WOZCA1200700001	4	12	23,0	14,7	11,2	110
120	95	DZRA 120 / 95	WOZCA1200950001	4	12	23,0	14,7	13,2	110
150	95	DZRA 150 / 95	WOZCA1500950001	4	12	25,0	16,3	13,2	130
150	120	DZRA 150 / 120	WOZCA1501200001	4	12	25,0	16,3	14,7	130
185	95	DZRA 185 / 95	WOZCA1850950001	4	12	28,5	18,3	13,2	130
185	120	DZRA 185 / 120	WOZCA1851200001	4	12	28,0	18,3	14,7	130
185	150	DZRA 185 / 150	WOZCA1851500001	4	12	28,0	18,3	16,3	130
240	35	DZRA 240 / 35	WOZCA2400350001	4	12	32,0	21,0	8,0	150
240	50	DZRA 240 / 50	WOZCA2400500001	4	12	32,0	21,0	9,8	150
240	70	DZRA 240 / 70	WOZCA2400700001	4	12	32,0	21,0	11,2	150
240	95	DZRA 240 / 95	WOZCA2400950001	4	12	32,0	21,0	13,2	150
240	120	DZRA 240 / 120	WOZCA2401200001	4	12	32,0	21,0	14,7	150
240	150	DZRA 240 / 150	WOZCA2401500001	4	12	32,0	21,0	16,3	150
240	185	DZRA 240 / 185	WOZCA2401850001	4	12	32,0	21,0	18,3	150

Aluminium reducing ferrules with the leakproof partition acc. to DIN standard - type DZRAP

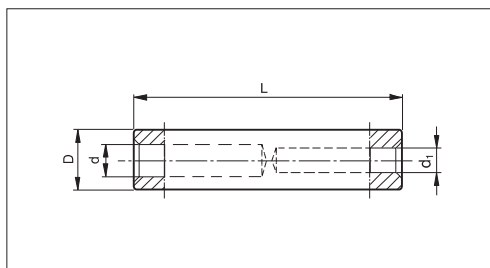
**Application**

For connection of round aluminum cores and sector - shaped conductors, voltage up to 6kV.
They increase the safety and life of connection.

Assembling

In order to make the durable assembling of ferrule, it should be pressed by using the suitable press (in case of sector cores - the core should be first formed round).

Technical data

Standard diameters DIN 46267 part.2. DIN standard DIN 46267 part.2 does not cover cross-sections 16 mm².

Material: aluminum bars drawing in the recrystallizing condition of EN AW-1050 Agrade PN-EN 573-3. With the leakproof partition. Special contact paste applied inside ferrules improve the quality of the connection.

For the assurance of suitable plasticity of contact paste, the ferrules are packed separately one piece in one folie sack.

Core cross section [mm ²] wejściowej	wyściowej	Type of ferrules	Index	Packing [pcs.]	Cumulative packing [pcs.]	Dimension [mm]			
						D	d	d ₁	L
25	10	DZRAP 25 / 10	WOZDA0250100001	4	48	12,0	6,8	4,9	65
50	25	DZRAP 50 / 25	WOZDA0500250001	4	20	16,0	9,8	6,8	90
70	16	DZRAP 70 / 16	WOZDA0700160001	4	20	18,5	11,2	5,6	112
70	25	DZRAP 70 / 25	WOZDA0700250001	4	20	18,5	11,2	6,8	112
70	35	DZRAP 70 / 35	WOZDA0700350001	4	20	18,5	11,2	8,0	112
95	35	DZRAP 95 / 35	WOZDA0950350001	4	20	22,0	13,2	8,0	113
95	70	DZRAP 95 / 70	WOZDA0950700001	4	20	22,0	13,2	11,2	113
120	25	DZRAP 120 / 25	WOZDA1200250001	4	12	23,0	14,7	6,8	115
120	35	DZRAP 120 / 35	WOZDA1200350001	4	12	23,0	14,7	8,0	115
120	50	DZRAP 120 / 50	WOZDA1200500001	4	12	23,0	14,7	9,8	115
120	70	DZRAP 120 / 70	WOZDA1200700001	4	12	23,0	14,7	11,2	115
120	95	DZRAP 120 / 95	WOZDA1200950001	4	12	23,0	14,7	13,2	115
185	150	DZRAP 185 / 150	WOZDA1851500001	4	12	28,5	18,3	16,3	135
240	35	DZRAP 240 / 35	WOZDA2400350001	4	12	32,0	21,0	8,0	155
240	50	DZRAP 240 / 50	WOZDA2400500001	4	12	32,0	21,0	9,8	155
240	95	DZRAP 240 / 95	WOZDA2400950001	4	12	32,0	21,0	13,2	155
240	120	DZRAP 240 / 120	WOZDA2401200001	4	12	32,0	21,0	14,7	155
240	150	DZRAP 240 / 150	WOZDA2401500001	4	12	32,0	21,0	16,3	155
240	185	DZRAP 240 / 185	WOZDA2401850001	4	12	32,0	21,0	18,3	155

DZRAP cable connectors are available on request, upon request.

Aluminium reducing ferrules with the partition acc. to DIN standard, voltage up to 10 ÷ 30kV - type DZROAP

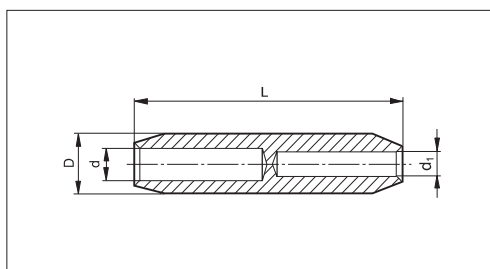

Application

For connection of round aluminum cores and sector - shaped conductors, voltage up to 10 ÷ 30kV. They increase the safety and life of connection.

Assembling

In order to make the durable assembling of ferrule, it should be pressed by using the suitable press (in case of sector cores - the core should be first formed round).

Technical data

Standard diameters DIN 46267 part.2. DIN standard DIN 46267 part.2 does not cover cross-sections 16 mm².

Material: aluminum bars drawing in the recrystallizing condition of EN AW-1050 Agrade PN-EN 573-3. With the leakproof partition. Special contact paste applied inside ferrules improve the quality of the connection.

For the assurance of suitable plasticity of contact paste, the ferrules are packed separately one piece in one folie sack.

Core cross section input	Core cross section output	Type of ferrules	Index	Packing [pcs.]	Cumulative packing [pcs.]	Dimension [mm]			
						D	d	d ₁	L
50	35	DZROAP 50 / 35	WOZJA0500350001	4	20	16,0	9,8	8,0	95
70	35	DZROAP 70 / 35	WOZJA0700350001	4	20	18,5	11,2	8,0	100
70	50	DZROAP 70 / 50	WOZJA0700500001	4	20	18,5	11,2	9,8	100
95	50	DZROAP 95 / 50	WOZJA0950500001	4	20	22,0	13,2	9,8	105
95	70	DZROAP 95 / 70	WOZJA0950700001	4	20	22,0	13,2	11,2	105
120	35	DZROAP 120 / 35	WOZJA1200350001	4	12	23,0	14,7	8,0	110
120	50	DZROAP 120 / 50	WOZJA1200500001	4	12	23,0	14,7	9,8	110
120	70	DZROAP 120 / 70	WOZJA1200700001	4	12	23,0	14,7	11,2	110
120	95	DZROAP 120 / 95	WOZJA1200950001	4	12	23,0	14,7	13,2	110
150	70	DZROAP 150 / 70	WOZJA1500700001	4	12	25,0	16,3	11,2	110
150	95	DZROAP 150 / 95	WOZJA1500950001	4	12	25,0	16,3	13,2	110
150	120	DZROAP 150 / 120	WOZJA1501200001	4	12	25,0	16,3	14,7	110
240	70	DZROAP 240 / 70	WOZJA2400700001	4	12	32,0	21,0	11,2	130
240	95	DZROAP 240 / 95	WOZJA2400950001	4	12	32,0	21,0	13,2	130
240	120	DZROAP 240 / 120	WOZJA2401200001	4	12	32,0	21,0	14,7	130
240	150	DZROAP 240 / 150	WOZJA2401500001	4	12	32,0	21,0	16,3	130
240	185	DZROAP 240 / 185	WOZJA2401850001	4	12	32,0	21,0	18,3	130

Aluminium ferrules, acc. to DIN standard, voltage up to 10 ÷ 30kV - type DZOA

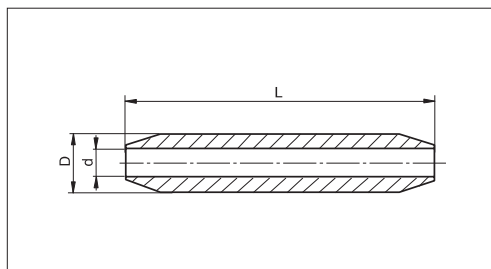
**Application**

For connection of round aluminum cores and sector - shaped conductors, voltage up to 10 ÷ 30kV. They increase the safety and life of connection.

Assembling

In order to make the durable assembling of ferrule, it should be pressed by using the suitable press (in case of sector cores - the core should be first formed round).

Technical data

Standard diameters DIN 46267 part.2. DIN standard DIN 46267 part.2 does not cover cross-section 16 mm².

Material: aluminum bars drawing in the recrystallizing condition of EN AW-1050 Agrade PN-EN 573-3. Special contact paste applied inside ferrules improve the quality of the connection.

For the assurance of suitable plasticity of contact paste, the ferrules are packed separately one piece in one folie sack.

Core cross section [mm ²] rm, sm	Type of ferrules	Index	Packing [pcs.]	Cumulative packing [pcs.]	Dimension [mm]		
					D	d	L
16	DZOA 16	WOZIA0160000001	4	48	12,0	5,6	60
25	DZOA 25	WOZIA0250000001	4	48	12,0	6,8	75
35	DZOA 35	WOZIA0350000001	4	48	14,0	8,0	90
50	DZOA 50	WOZIA0500000001	4	20	16,0	9,8	90
70	DZOA 70	WOZIA0700000001	4	20	18,5	11,2	95
95	DZOA 95	WOZIA0950000001	4	20	22,0	13,2	100
120	DZOA 120	WOZIA1200000001	4	12	23,0	14,7	105
150	DZOA 150	WOZIA1500000001	4	12	25,0	16,3	105
185	DZOA 185	WOZIA1850000001	4	12	28,5	18,3	125
240	DZOA 240	WOZIA2400000001	4	12	32,0	21,0	125

rm - round bunched core, sm - segmental bunched core, se - segmental solid core.

Aluminium ferrules with the partition, acc. to DIN standard, voltage up to 10 ÷ 30kV - type DZOAP

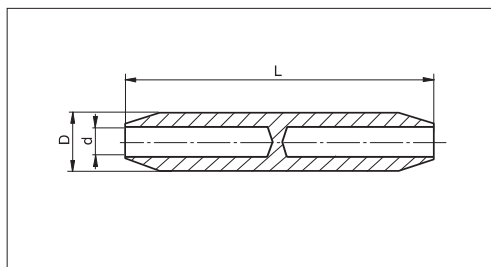

Application	For connection of round aluminum cores and sector - shaped conductors, voltage up to 10 ÷ 30kV. They increase the safety and life of connection.
Assembling	In order to make the durable assembling of ferrule, it should be pressed by using the suitable press (in case of sector cores - the core should be first formed round).
Technical data	Standard diameters DIN 46267 part.2. DIN standard DIN 46267 part.2 does not cover cross-sections 16 mm ² . Material: aluminum bars drawing in the recrystallizing condition of EN AW-1050 Agrade PN-EN 573-3. With the leakproof partition. Special contact paste applied inside ferrules improve the quality of the connection. For the assurance of suitable plasticity of contact paste, the ferrules are packed separately one piece in one folie sack.

Core cross section [mm ²] rm, sm	Type of ferrules	Index	Packing [pcs.]	Cumulative packing [pcs.]	Dimension [mm]		
					D	d	L
35	DZOAP 35	WOZJA0350000001	4	48	14,0	8,0	95
50	DZOAP 50	WOZJA0500000001	4	20	16,0	9,8	95
70	DZOAP 70	WOZJA0700000001	4	20	18,5	11,2	100
95	DZOAP 95	WOZJA0950000001	4	20	22,0	13,2	105
120	DZOAP 120	WOZJA1200000001	4	12	23,0	14,7	110
150	DZOAP 150	WOZJA1500000001	4	12	25,0	16,3	110
185	DZOAP 185	WOZJA1850000001	4	12	28,5	18,3	130
240	DZOAP 240	WOZJA2400000001	4	12	32,0	21,0	130

rm - round bunched core, sm - segmental bunched core, se - segmental solid core.

Full-tension notch type midspan connectors - type of ferrules ZL

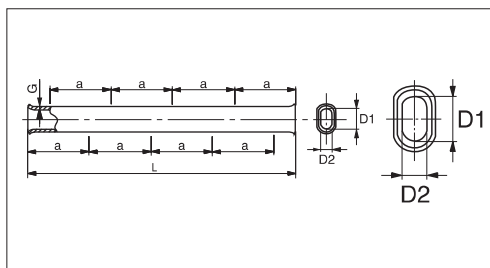
**Application**

For overhead power lines. Used for connection of two bare aluminum conductors of the same diameters with the use of crimper or for terminating of loop on post insulators or pull handles.

Assembling

Insert multicore cables in parallel that they protrude evenly at both ends. To secure permanently, press with an appropriate crimping pliers.

Technical data

Material: aluminum. Made in accordance with BN-86 / 0325-29

Type of ferrules	Index	Packing [pcs.]	Cumulative packing [pcs.]	Dimensions [mm]					No. of crimps on one side
				D ₁	D ₂	G	L	a	
ZL 16	WOZHA0160000001	20	300	11	5,6	1	98	28	3
ZL 25	WOZHA0250000001	20	200	13,5	7	1,5	112	32	3
ZL 35	WOZHA0350000001	20	120	16	8	1,5	126	36	3
ZL 50	WOZHA0500000001	20	100	19,5	10	1,5	180	40	4
ZL 70	WOZHA0700000001	20	100	22,5	11,5	1,5	198	44	4

Full-tension notch type midspan connectors with spacer - type of ferrules ZLF, ZLFD

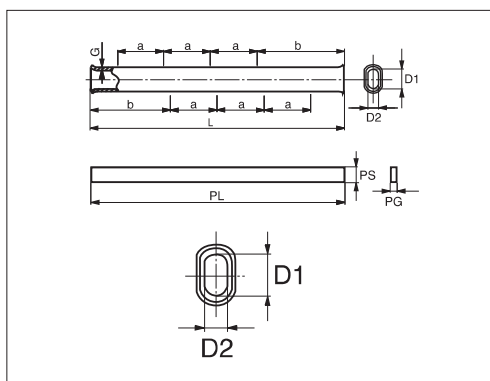

Application

For overhead power lines. Used for connection of two bare steel-aluminum conductors of the same diameters with the use of crimper or for terminating of loop on post insulators or pull handles.

Technical data

Material: aluminum. Made in accordance with BN-86 / 0325-29.

Type of ferrules	Index	Packing [pcs.]	Cumulative packing [pcs.]	Dimensions [mm]									No. of crimps on one side
				D ₁	D ₂	G	L	a	b	PL	PS	PG	
ZLF 25	WOZHL0250000001	20	100	16,5	7,5	2	112	32	32	140	6,5	1,5	3
ZLF 35	WOZHL0350000001	20	100	19	9	2	130	37	37	160	8,0	1,5	3
ZLF 50	WOZHL0500000001	20	100	22	10,5	2	184	41	41	220	9,0	1,5	4
ZLF 70	WOZHL0700000001	20	100	26	12,5	2,5	205	46	46	240	11,0	1,5	4
ZLFD 25	WOZHL0250000002	20	100	16,5	7,5	2	270	36	36	310	6,5	1,5	7
ZLFD 35	WOZHL0350000002	20	100	19	9	2	306	36	72	350	8,0	1,5	7
ZLFD 50	WOZHL0500000002	20	100	22	10,5	2	380	40	80	430	9,0	1,5	8
ZLFD 70	WOZHL0700000002	20	100	26	12,5	2,5	462	44	132	520	11,0	1,5	8

Copper cable terminals - type K, KS

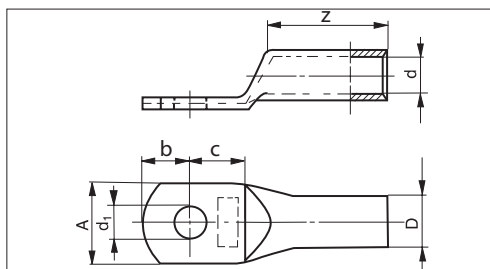

K - Terminals without galvanic coating KS - Tinned terminals

Application For termination of round and sector shape copper conductors for voltage up to 1kV. They increase the safety and life of connection.

Assembling In order to make the durable assembling of terminal, it should be pressed by using the suitable press (in case of sector cores - the core should be first formed round).

Technical data Material: copper pipes and bars of grade Cu-ETP acc. with PN EN 13600, PN EN 13601. KS terminals have electroplated protective tin coatings.

Core cross sect. [mm ²]	Type of terminals	Index	Type of terminals	Index	Packing [pcs.]	C. packing [pcs.]	Dimensions [mm]						
							D	d	d ₁	A	b	c	z
2,5	K 2,5/4	TOKAC0020000401	KS 2,5/4	TOKAZ0020000401	100	7000	4	2,4	4,2	8	4	5	7
4	K 4/5	TOKAC0040000501	KS 4/5	TOKAZ0040000501	100	6000	4,5	2,9	5,3	10	5	6	7
4	K 4/6	TOKAC0040000601	KS 4/6	TOKAZ0040000601	100	6000	4,5	2,9	6,5	10	5	6	7
4	K 4/8	TOKAC0040000801	KS 4/8	TOKAZ0040000801	100	6000	4,5	2,9	8,5	12,5	6,5	7	7
6	K 6/5	TOKAC0060000501	KS 6/5	TOKAZ0060000501	100	5000	5,5	3,8	5,3	10	5	6	9
6	K 6/6	TOKAC0060000601	KS 6/6	TOKAZ0060000601	100	5000	5,5	3,8	6,5	12	6	9	9
6	K 6/8	TOKAC0060000801	KS 6/8	TOKAZ0060000801	100	5000	5,5	3,8	8,5	12,5	6	9	9
10	K 10/5	TOKAC0100000501	KS 10/5	TOKAZ0100000501	100	2500	6,2	4,5	5,3	12	6	7	9
10	K 10/6	TOKAC0100000601	KS 10/6	TOKAZ0100000601	100	2500	6,2	4,5	6,5	12	6	7	9
10	K 10/8	TOKAC0100000801	KS 10/8	TOKAZ0100000801	100	2500	6,2	4,5	8,5	12,5	7	8	9
10	K 10/10	TOKAC0100001001	KS 10/10	TOKAZ0100001001	100	2500	6,2	4,5	10,5	15	8	8	9
16	K 16/5	WOKAC0160000501	KS 16/5	WOKAZ0160000501	50	1100	8,5	5,5	5,5	12,5	6,5	8	13
16	K 16/6	WOKAC0160000601	KS 16/6	WOKAZ0160000601	50	1100	8,5	5,5	6,5	12,5	6,5	8	13
16	K 16/8	WOKAC0160000801	KS 16/8	WOKAZ0160000801	50	1100	8,5	5,5	8,5	14,5	10	10	13
16	K 16/10	WOKAC0160001001	KS 16/10	WOKAZ0160001001	50	1100	8,5	5,5	10,5	17	10	10	13
16	K 16/12	WOKAC0160001201	KS 16/12	WOKAZ0160001201	50	1100	8,5	5,5	13	18,5	12,5	13,5	13
25	K 25/6	WOKAC0250000601	KS 25/6	WOKAZ0250000601	50	800	10	7	6,5	16	8	8	16
25	K 25/8	WOKAC0250000801	KS 25/8	WOKAZ0250000801	50	800	10	7	8,5	16	10	10	16
25	K 25/10	WOKAC0250001001	KS 25/10	WOKAZ0250001001	50	500	10	7	10,5	18	12,5	12,5	16
25	K 25/12	WOKAC0250001201	KS 25/12	WOKAZ0250001201	50	500	10	7	13	18	12,5	14	16
35	K 35/6	WOKAC0350000601	KS 35/6	WOKAZ0350000601	50	600	12	8,5	6,5	18	7,5	8	18
35	K 35/8	WOKAC0350000801	KS 35/8	WOKAZ0350000801	50	600	12	8,5	8,5	18	10	11	18
35	K 35/10	WOKAC0350001001	KS 35/10	WOKAZ0350001001	50	500	12	8,5	11	19	12,5	12,5	18
35	K 35/12	WOKAC0350001201	KS 35/12	WOKAZ0350001201	50	500	12	8,5	13	20	12,5	13,5	18
50	K 50/6	WOKAC0500000601	KS 50/6	WOKAZ0500000601	20	300	14	10	6,5	20	11	11,5	19
50	K 50/8	WOKAC0500000801	KS 50/8	WOKAZ0500000801	20	300	14	10	8,5	20	11	11	19
50	K 50/10	WOKAC0500001001	KS 50/10	WOKAZ0500001001	20	300	14	10	11	20	12,5	12,5	19
50	K 50/12	WOKAC0500001201	KS 50/12	WOKAZ0500001201	20	300	14	10	13	21	12,5	13,5	19
50	K 50/14	WOKAC0500001401	KS 50/14	WOKAZ0500001401	20	300	14	10	14,5	23	14,5	15,5	19
50	K 50/16	WOKAC0500001601	KS 50/16	WOKAZ0500001601	20	300	14	10	17	28	17	17	19
70	K 70/6	WOKAC0700000601	KS 70/6	WOKAZ0700000601	20	240	16,5	12,1	6,5	23	11	11	22
70	K 70/8	WOKAC0700000801	KS 70/8	WOKAZ0700000801	20	240	16,5	12,1	8,5	23	11	11	22
70	K 70/10	WOKAC0700001001	KS 70/10	WOKAZ0700001001	20	240	16,5	12,1	11	23	12,5	12,5	22
70	K 70/12	WOKAC0700001201	KS 70/12	WOKAZ0700001201	20	240	16,5	12,1	13	23	12,5	13,5	22
70	K 70/14	WOKAC0700001401	KS 70/14	WOKAZ0700001401	20	240	16,5	12,1	14,5	23	14,5	15,5	22
70	K 70/16	WOKAC0700001601	KS 70/16	WOKAZ0700001601	20	240	16,5	12,1	17	28	17	17	22
95	K 95/6	WOKAC0950000601	KS 95/6	WOKAZ0950000601	20	200	18	13,6	6,3	26	11	11	26
95	K 95/8	WOKAC0950000801	KS 95/8	WOKAZ0950000801	20	200	18	13,6	8,4	26	11	11	26
95	K 95/10	WOKAC0950001001	KS 95/10	WOKAZ0950001001	20	200	18	13,6	11	26	12,5	12,5	26
95	K 95/12	WOKAC0950001201	KS 95/12	WOKAZ0950001201	20	200	18	13,6	13	26	12,5	13,5	26

Copper cable terminals - type K, KS - continued

Core cross sect. [mm ²]	Type of terminals	Index	Type of terminals	Index	Packing		Dimensions [mm]						
					C. packing [pcs.]	packing [pcs.]	D	d	d ₁	A	b	c	z
95	K 95/16	WOKAC0950001601	KS 95/16	WOKAZ0950001601	20	200	18	13,6	17	28	17	17	26
120	K 120/8	WOKAC1200000801	KS 120/8	WOKAZ1200000801	10	150	19,5	15,1	8,5	29	11	11	26
120	K 120/10	WOKAC1200001001	KS 120/10	WOKAZ1200001001	10	150	19,5	15,1	11	29	12,5	12,5	26
120	K 120/12	WOKAC1200001201	KS 120/12	WOKAZ1200001201	10	150	19,5	15,1	13	29	12,5	13,5	26
120	K 120/16	WOKAC1200001601	KS 120/16	WOKAZ1200001601	10	150	19,5	15,1	17	30	17	17	26
150	K 150/8	WOKAC1500000801	KS 150/8	WOKAZ1500000801	10	100	21	16,5	8,3	31	11,5	11	30
150	K 150/10	WOKAC1500001001	KS 150/10	WOKAZ1500001001	10	100	21	16,5	11	31	12,5	12,5	30
150	K 150/12	WOKAC1500001201	KS 150/12	WOKAZ1500001201	10	100	21	16,5	13	31	12,5	13,5	30
150	K 150/16	WOKAC1500001601	KS 150/16	WOKAZ1500001601	10	100	21	16,5	17	31	17	17	30
185	K 185/8	WOKAC1850000801	KS 185/8	WOKAZ1850001001	10	80	24	19	8,4	35	11	11	30
185	K 185/10	WOKAC1850001001	KS 185/10	WOKAZ1850001201	10	80	24	19	11	35	12,5	12,5	30
185	K 185/12	WOKAC1850001201	KS 185/12	WOKAZ1850001401	10	80	24	19	13	35	12,5	13,5	30
185	K 185/16	WOKAC1850001601	KS 185/16	WOKAZ1850002001	10	80	24	19	17	35	17	17	30
240	K 240/10	WOKAC2400001001	KS 240/10	WOKAZ2400001201	10	80	26	21	11	38	13	12,5	35
240	K 240/12	WOKAC2400001201	KS 240/12	WOKAZ2400001401	10	80	26	21	13	38	12,5	13,5	35
240	K 240/14	WOKAC2400001401	KS 240/14	WOKAZ2400001601	10	80	26	21	14,5	38	15	15	35
240	K 240/16	WOKAC2400001601	KS 240/16	WOKAZ2400002001	10	80	26	21	17	38	17	17	35
300	K 300/10	WOKAC3000001001	KS 300/10	WOKAZ3000001201	10	50	30	24	11	43	12,5	13,5	45
300	K 300/12	WOKAC3000001201	KS 300/12	WOKAZ3000001401	10	50	30	24	13,0	43	14,5	15,5	45
300	K 300/14	WOKAC3000001401	KS 300/14	WOKAZ3000001601	10	50	30	24	14,5	43	14,5	15,5	45
300	K 300/16	WOKAC3000001601	KS 300/16	WOKAZ3000002001	10	50	30	24	17	43	17	17	45

Copper cable terminals acc. to DIN standard, voltage up to 30kV - type DK, DKS

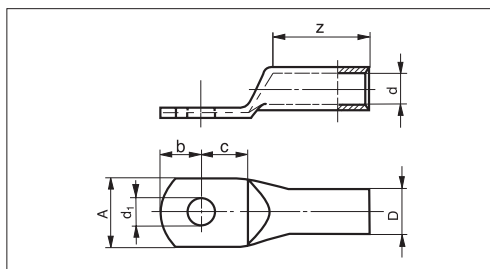

DK - Terminals without galvanic coating
DKS - Tinned terminals

Application	For termination of round and sector shape copper conductors for voltage up to 30kV. They increase the safety and life of connection.
Assembling	In order to make the durable assembling of terminal, it should be pressed by using the suitable press (in case of sector cores - the core should be first formed round).
Technical data	Dimensions according to DIN 46235. Material: copper pipes and bars of grade Cu-ETP acc. with PN PN-EN 13600, PN-EN 13601. DKPS terminals have electroplated protective tin coatings.

Core cross sect. [mm ²]	Type of terminals	Index	Type of terminals	Index	Packing [pcs.]	C. packing [pcs.]	Dimensions [mm]						
							D	d	d ₁	A	b	c	z
16	DK 16/6.	WOKCC0160000601	DKS 16/6.	WOKCZ0160000601	50	1000	8,5	5,5	6,4	13	10,5	8	20
16	DK 16/8.	WOKCC0160000801	DKS 16/8.	WOKCZ0160000801	50	1000	8,5	5,5	8,4	13	13	10	20
25	DK 25/8.	WOKCC0250000801	DKS 25/8.	WOKCZ0250000801	50	500	10	7	8,4	16	13	10	20
25	DK 25/10.	WOKCC0250001001	DKS 25/10.	WOKCZ0250001001	50	500	10	7	10,5	17	15	12	20
35	DK 35/8.	WOKCC0350000801	DKS 35/8.	WOKCZ0350000801	50	500	12,5	8,2	8,4	17	13	10	20
35	DK 35/10.	WOKCC0350001001	DKS 35/10.	WOKCZ0350001001	50	500	12,5	8,2	10,5	19	15	12	20
50	DK 50/8.	WOKCC0500000801	DKS 50/8.	WOKCZ0500000801	20	200	14,5	10	8,4	20	13	10	28
50	DK 50/10.	WOKCC0500001001	DKS 50/10.	WOKCZ0500001001	20	200	14,5	10	10,5	22	15	12	28
50	DK 50/12.	WOKCC0500001201	DKS 50/12.	WOKCZ0500001201	20	200	14,5	10	13	24	16	13	28
70	DK 70/8.	WOKCC0700800001	DKS 70/8.	WOKCZ0700000801	20	200	16,5	11,5	8,4	24	13	10	28
70	DK 70/10.	WOKCC0701000001	DKS 70/10.	WOKCZ0700001001	20	200	16,5	11,5	10,5	24	15	12	28
70	DK 70/12.	WOKCC0701200001	DKS 70/12.	WOKCZ0700001201	20	200	16,5	11,5	13	24	16	13	28
95	DK 95/8.	WOKCC0950000801	DKS 95/8.	WOKCZ0950000801	20	140	19	13,5	8,5	28	13	10	35
95	DK 95/10.	WOKCC0950001001	DKS 95/10.	WOKCZ0950001001	20	140	19	13,5	10,5	28	15	12	35
95	DK 95/12.	WOKCC0950001201	DKS 95/12.	WOKCZ0950001201	20	140	19	13,5	13	28	16	13	35
120	DK 120/10.	WOKCC1200001201	DKS 120/10.	WOKCZ1200001001	10	100	21	15,5	10,5	32	15	12	35
120	DK 120/12.	WOKCC1200001401	DKS 120/12.	WOKCZ1200001201	10	100	21	15,5	13	32	16	13	35
120	DK 120/16.	WOKCC1500001001	DKS 120/16.	WOKCZ1200001601	10	100	21	15,5	17	32	19	16	35
150	DK 150/12.	WOKCC1500001201	DKS 150/12.	WOKCZ1500001201	10	80	23,5	17	13	34	16	13	35
150	DK 150/16.	WOKCC1500001601	DKS 150/16.	WOKCZ1500001601	10	80	23,5	17	17	34	19	16	35
185	DK 185/12.	WOKCC1850001201	DKS 185/12.	WOKCZ1850001201	10	50	25,5	19	13	37	16	13	40
185	DK 185/16.	WOKCC1850001601	DKS 185/16.	WOKCZ1850001601	10	50	25,5	19	17	37	19	16	40
240	DK 240/12.	WOKCC2400001201	DKS 240/12.	WOKCZ2400001201	10	50	29	21,5	13	42	16	13	40
240	DK 240/16.	WOKCC2400001601	DKS 240/16.	WOKCZ2400001601	10	50	29	21,5	17	42	19	16	40
300	DK 300/12.	WOKCC3000001201	DKS 300/12.	WOKCZ3000001201	4	12	32	24,5	13	48	19	16	50
300	DK 300/16.	WOKCC3000001601	DKS 300/16.	WOKCZ3000001601	4	12	32	24,5	17	48	19	16	50
300	DK 300/20.	WOKCC3000002001	DKS 300/20.	WOKCZ3000002001	4	12	32	24,5	21	48	22	20	50
400	DK 400/16.	WOKCC4000001601	DKS 400/16.	WOKCZ4000001601	4	12	38,5	27,5	17	55	25	16	70
400	DK 400/20.	WOKCC4000002001	DKS 400/20.	WOKCZ4000002001	4	12	38,5	27,5	21	55	25	20	70
500	DK 500/16.	WOKCC5000001601	DKS 500/16.	WOKCZ5000001601	4	12	42	31	17	60	25	20	70
500	DK 500/20.	WOKCC5000002001	DKS 500/20.	WOKCZ5000002001	4	12	42	31	21	60	25	20	70
625	DK 625/16.	WOKCC6250001601	DKS 625/16.	WOKCZ6250001601	4	12	44	34,5	17	60	25	20	80
625	DK 625/20.	WOKCC6250002001	DKS 625/20.	WOKCZ6250002001	4	12	44	34,5	21	60	25	20	80

DKPS terminals are available on request, upon request.

Angular copper cable terminals 45° - type KU, KUS

ON REQUEST

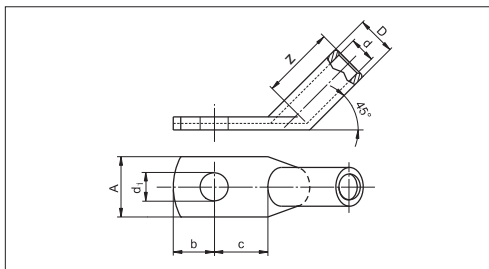

KU - Angular cable terminals 45°, without galvanic coating
KUS - Tinned angular cable terminals 45°

Application	For termination of round and sector shape copper conductors for voltage up to 1kV. They increase the safety and life of connection.
Assembling	In order to make the durable assembling of terminal, it should be pressed by using the suitable press (in case of sector cores - the core should be first formed round)..
Technical data	Material: copper pipes and bars of grade Cu-ETP acc. with PN PN-EN 13600, PN-EN 13601. KUS terminals have electroplated protective tin coatings.

Core cross sect. [mm ²]	Type of terminals	Index	Type of terminals	Index	Packing		Dimensions [mm]						
					C. [pcs.]	packing [pcs.]	D	d	d ₁	A	b	c	z
16	KU 16/5	WOKEC0160000501	KUS 16/5	WOKEZ0160000501	50	800	8,5	5,5	5,5	12,5	6,5	8	13
16	KU 16/6	WOKEC0160000601	KUS 16/6	WOKEZ0160000601	50	800	8,5	5,5	6,5	12,5	6,5	8	13
16	KU 16/8	WOKEC0160000801	KUS 16/8	WOKEZ0160000801	50	800	8,5	5,5	8,5	14,5	10	10	13
16	KU 16/10	WOKEC0160001001	KUS 16/10	WOKEZ0160001001	50	800	8,5	5,5	11	17	10	10	13
16	KU 16/12	WOKEC0160001201	KUS 16/12	WOKEZ0160001201	50	800	8,5	5,5	13	18,5	12,5	13,5	13
25	KU 25/6	WOKEC0250000601	KUS 25/6	WOKEZ0250000601	50	500	10	7	6,5	16	8	8	16
25	KU 25/8	WOKEC0250000801	KUS 25/8	WOKEZ0250000801	50	500	10	7	8,5	16	10	10	16
25	KU 25/10	WOKEC0250001001	KUS 25/10	WOKEZ0250001001	50	500	10	7	11	18	12,5	12,5	16
25	KU 25/12	WOKEC0250001201	KUS 25/12	WOKEZ0250001201	50	500	10	7	13	18	12,5	14	16
35	KU 35/6	WOKEC0350000601	KUS 35/6	WOKEZ0350000601	50	300	12	8,5	6,5	18	7,5	8	17
35	KU 35/8	WOKEC0350000801	KUS 35/8	WOKEZ0350000801	50	300	12	8,5	8,5	18	10	11	17
35	KU 35/10	WOKEC0350001001	KUS 35/10	WOKEZ0350001001	50	300	12	8,5	11	19	12,5	12,5	17
35	KU 35/12	WOKEC0350001201	KUS 35/12	WOKEZ0350001201	50	300	12	8,5	13	20	12,5	13,5	17
50	KU 50/8	WOKEC0500000801	KUS 50/8	WOKEZ0500000801	20	240	14	10	8,5	20	11	11	20
50	KU 50/10	WOKEC0500001001	KUS 50/10	WOKEZ0500001001	20	240	14	10	11	20	12,5	12,5	20
50	KU 50/12	WOKEC0500001801	KUS 50/12	WOKEZ0500001201	20	240	14	10	13	21	12,5	13,5	20
50	KU 50/14	WOKEC0500001401	KUS 50/14	WOKEZ0500001401	20	240	14	10	15	23	14,5	15,5	20
50	KU 50/16	WOKEC0500001601	KUS 50/16	WOKEZ0500001601	20	240	14	10	17	28	17	17	20
70	KU 70/8	WOKEC0700000801	KUS 70/8	WOKEZ0700000801	20	200	16,5	12,1	8,5	23	11	11	21
70	KU 70/10	WOKEC0700001001	KUS 70/10	WOKEZ0700001001	20	200	16,5	12,1	11	23	12,5	12,5	21
70	KU 70/12	WOKEC0700001201	KUS 70/12	WOKEZ0700001201	20	200	16,5	12,1	13	23	12,5	13,5	21
70	KU 70/14	WOKEC0700001401	KUS 70/14	WOKEZ0700001401	20	200	16,5	12,1	15	23	14,5	15,5	21
70	KU 70/16	WOKEC0700001601	KUS 70/16	WOKEZ0700001601	20	200	16,5	12,1	17	28	17	17	21
95	KU 95/8	WOKEC0950000801	KUS 95/8	WOKEZ0950000801	20	140	18	13,6	8,5	26	11	11	23,5
95	KU 95/10	WOKEC0950001001	KUS 95/10	WOKEZ0950001001	20	140	18	13,6	11	26	12,5	12,5	23,5
95	KU 95/12	WOKEC0950001201	KUS 95/12	WOKEZ0950001201	20	140	18	13,6	13	26	12,5	13,5	23,5
95	KU 95/14	WOKEC0950001401	KUS 95/14	WOKEZ0950001401	20	140	18	13,6	15	26	14,5	15,5	23,5
95	KU 95/16	WOKEC0950001601	KUS 95/16	WOKEZ0950001601	20	140	18	13,6	17	28	17	17	23,5
120	KU 120/8	WOKEC1200000801	KUS 120/8	WOKEZ1200000801	10	100	19,5	15,1	8,5	29	11	11	26
120	KU 120/10	WOKEC1200001001	KUS 120/10	WOKEZ1200001001	10	100	19,5	15,1	11	29	12,5	12,5	26
120	KU 120/12	WOKEC1200001201	KUS 120/12	WOKEZ1200001201	10	100	19,5	15,1	13	29	12,5	13,5	26
120	KU 120/14	WOKEC1200001401	KUS 120/14	WOKEZ1200001401	10	100	19,5	15,1	15	29	14,5	15,5	26
120	KU 120/16	WOKEC1200001601	KUS 120/16	WOKEZ1200001601	10	100	19,5	15,1	17	30	17	17	26
120	KU 120/20	WOKEC1200002001	KUS 120/20	WOKEZ1200002001	10	100	19,5	15,1	21	30	20	20	26
150	KU 150/10	WOKEC1500001001	KUS 150/10	WOKEZ1500001001	10	80	21	16,5	11	31	12,5	12,5	30
150	KU 150/12	WOKEC1500001201	KUS 150/12	WOKEZ1500001201	10	80	21	16,5	13	31	12,5	13,5	30
150	KU 150/14	WOKEC1500001401	KUS 150/14	WOKEZ1500001401	10	80	21	16,5	15	31	15,5	14,5	30
150	KU 150/16	WOKEC1500001601	KUS 150/16	WOKEZ1500001601	10	80	21	16,5	17	31	17	17	30
150	KU 150/20	WOKEC1500002001	KUS 150/20	WOKEZ1500002001	10	80	21	16,5	21	36	20	20	30
185	KU 185/10	WOKEC1850001001	KUS 185/10	WOKEZ1850001001	10	50	24	19	11	35	12,5	12,5	30
185	KU 185/12	WOKEC1850001201	KUS 185/12	WOKEZ1850001201	10	50	24	19	13	35	12,5	13,5	30
185	KU 185/14	WOKEC1850001401	KUS 185/14	WOKEZ1850001401	10	50	24	19	15	35	15,5	15,5	30
185	KU 185/16	WOKEC1850001601	KUS 185/16	WOKEZ1850001601	10	50	24	19	17	35	17	17	30
185	KU 185/20	WOKEC1850002001	KUS 185/20	WOKEZ1850002001	10	50	24	19	21	37	20	20	30
240	KU 240/10	WOKEC2400001001	KUS 240/10	WOKEZ2400001001	10	50	26	21	11	38	13	12,5	35
240	KU 240/12	WOKEC2400001201	KUS 240/12	WOKEZ2400001201	10	50	26	21	13	38	12,5	13,5	35
240	KU 240/14	WOKEC2400001401	KUS 240/14	WOKEZ2400001401	10	50	26	21	15	38	15	15	35
240	KU 240/16	WOKEC2400001601	KUS 240/16	WOKEZ2400001601	10	50	26	21	17	38	17	17	35
240	KU 240/20	WOKEC2400002001	KUS 240/20	WOKEZ2400002001	10	50	26	21	21	40	20	20	35

KUS terminals are available on request, upon request.

Angular copper cable terminals 45°, acc. to DIN standard, voltage up to 30kV - type DKU, DKUS

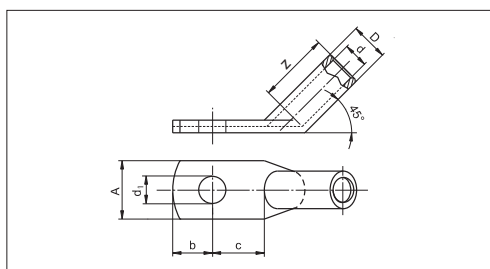

DKU - Angular 45° without galvanic coating
DKUS - Angular cable terminals 45°

Application

For termination of round and sector shape copper conductors for voltage up to 30kV. They increase the safety and life of connection.

Assembling

In order to make the durable assembling of terminal, it should be pressed by using the suitable press (in case of sector cores - the core should be first formed round).

Technical data

Dimensions of the tubing in accordance with DIN 46235.

Material: copper pipes and bars of grade Cu-ETP acc. with PN PN-EN 13600, PN-EN 13601.

DKUS terminals have electroplated protective tin coatings.

Core cross sect. [mm ²]	Type of terminals	Index	Type of terminals	Index	Pack. [pcs.]	C. pack. [pcs.]	Dimensions [mm]						
							D	d	d ₁	A	b	c	z
16	DKU 16/5	WOKFC0160000501	DKUS 16/5	WOKFZ0160000501	50	800	8,5	5,5	5,5	13	7	6	20
16	DKU 16/6.	WOKFC0160000601	DKUS 16/6.	WOKFZ0160000601	50	800	8,5	5,5	6,5	13	8,5	8	20
16	DKU 16/8	WOKFC0160000801	DKUS 16/8	WOKFZ0160000801	50	800	8,5	5,5	8,5	13	11	10	20
16	DKU 16/10	WOKFC0250000601	DKUS 16/10	WOKFZ0160001001	50	800	8,5	5,5	10,5	17	13	12	20
25	DKU 25/6	WOKFC0250000601	DKUS 25/6	WOKFZ0250000601	50	500	10	7	6,5	14	8,5	8	20
25	DKU 25/8.	WOKFC0250000801	DKUS 25/8.	WOKFZ0250000801	50	500	10	7	8,5	16	11	10	20
25	DKU 25/10	WOKFC0250001001	DKUS 25/10	WOKFZ0250001001	50	500	10	7	10,5	17	13	12	20
25	DKU 25/12	WOKFC0250001201	DKUS 25/12	WOKFZ0250001201	50	500	10	7	13	19	14	13	20
35	DKU 35/6	WOKFC0350000601	DKUS 35/6	WOKFZ0350000601	50	300	12,5	8,2	6,5	17	8,5	8	20
35	DKU 35/8.	WOKFC0350000802	DKUS 35/8.	WOKFZ0350000801	50	300	12,5	8,2	8,5	17	11	10	20
35	DKU 35/10	WOKFC0350001001	DKUS 35/10	WOKFZ0350001001	50	300	12,5	8,2	10,5	19	13	12	20
35	DKU 35/12	WOKFC0350001201	DKUS 35/12	WOKFZ0350001201	50	300	12,5	8,2	13	21	14	13	20
50	DKU 50/8	WOKFC0500000801	DKUS 50/8	WOKFZ0500000801	20	240	14,5	10	8,5	20	11	10	28
50	DKU 50/10.	WOKFC0500001001	DKUS 50/10.	WOKFZ0500001001	20	240	14,5	10	10,5	22	13	12	28
50	DKU 50/12	WOKFC0500001201	DKUS 50/12	WOKFZ0500001201	20	240	14,5	10	13	24	14	13	28
50	DKU 50/14	WOKFC0500001401	DKUS 50/14	WOKFZ0500001401	20	240	14,5	10	15	28	17	16	28
50	DKU 50/16	WOKFC0500001601	DKUS 50/16	WOKFZ0500001601	20	240	14,5	10	17	28	17	16	28
70	DKU 70/8	WOKFC0700000801	DKUS 70/8	WOKFZ0700000801	20	200	16,5	11,5	8,5	24	11	10	28
70	DKU 70/10.	WOKFC0700001001	DKUS 70/10.	WOKFZ0700001001	20	200	16,5	11,5	10,5	24	13	12	28
70	DKU 70/12	WOKFC0700001201	DKUS 70/12	WOKFZ0700001201	20	200	16,5	11,5	13	24	14	13	28
70	DKU 70/14	WOKFC0700001401	DKUS 70/14	WOKFZ0700001401	20	200	16,5	11,5	15	30	17	16	28
70	DKU 70/16	WOKFC0700001601	DKUS 70/16	WOKFZ0700001601	20	200	16,5	11,5	17	30	17	16	28
95	DKU 95/8	WOKFC0950000801	DKUS 95/8	WOKFZ0950000801	20	140	19	13,5	8,5	28	11	10	35
95	DKU 95/10.	WOKFC0950001001	DKUS 95/10.	WOKFZ0950001001	20	140	19	13,5	10,5	28	13	12	35
95	DKU 95/12	WOKFC0950001201	DKUS 95/12	WOKFZ0950001201	20	140	19	13,5	13	28	14	13	35
95	DKU 95/14	WOKFC0950001401	DKUS 95/14	WOKFZ0950001401	20	140	19	13,5	15	32	17	16	35
95	DKU 95/16	WOKFC0950001601	DKUS 95/16	WOKFZ0950001601	20	140	19	13,5	17	32	17	16	35
120	DKU 120/8	WOKFC1200000801	DKUS 120/8	WOKCZ1200000801	10	100	21	15,5	8,5	32	11	10	35
120	DKU 120/10	WOKFC1200001001	DKUS 120/10	WOKFZ1200001001	20	100	21	15,5	10,5	32	13	12	35
120	DKU 120/12.	WOKFC1200001201	DKUS 120/12.	WOKFZ1200001201	10	100	21	15,5	13	32	14	13	35
120	DKU 120/14	WOKFC1200001401	DKUS 120/14	WOKFZ1200001401	10	100	21	15,5	15	32	17	16	35
120	DKU 120/16	WOKFC1200001601	DKUS 120/16	WOKFZ1200001601	10	100	21	15,5	17	32	17	16	35
120	DKU 120/20	WOKFC1200002001	DKUS 120/20	WOKFZ1200002001	10	100	21	15,5	21	38	20	20	35
150	DKU 150/10	WOKFC1500001001	DKUS 150/10	WOKFZ1500001001	10	80	23,5	17	10,5	34	13	12	35
150	DKU 150/12.	WOKFC1500001201	DKUS 150/12.	WOKFZ1500001201	10	80	23,5	17	13	34	14	13	35
150	DKU 150/14	WOKFC1500001401	DKUS 150/14	WOKFZ1500001401	10	80	23,5	17	15	34	17	16	35

Angular copper cable terminals 45°, acc. to DIN standard, voltage up to 30kV - type DKU, DKUS - continued

Core cross sect. [mm ²]	Type of terminals	Index	Type of terminals	Index	Pack. [pcs.]	C. pac. [pcs.]	Dimensions [mm]						
							D	d	d ₁	A	b	c	z
150	DKU 150/16	WOKFC1500001601	DKUS 150/16	WOKFZ1500001601	10	80	23,5	17	17	34	17	16	35
150	DKU 150/20	WOKFC1500002001	DKUS 150/20	WOKFZ1500002001	10	80	23,5	17	21	40	20	20	35
185	DKU 185/10	WOKFC1850001001	DKUS 185/10	WOKFZ1850001001	10	50	25,5	19	10,5	37	13	12	40
185	DKU 185/12	WOKFC1850001201	DKUS 185/12	WOKFZ1850001201	10	50	25,5	19	13	37	14	13	40
185	DKU 185/14	WOKFC1850001401	DKUS 185/14	WOKFZ1850001401	10	50	25,5	19	15	37	17	16	40
185	DKU 185/16	WOKFC1850001601	DKUS 185/16	WOKFZ1850001601	10	50	25,5	19	17	37	17	16	40
185	DKU 185/20	WOKFC1850002001	DKUS 185/20	WOKFZ1850002001	10	50	25,5	19	21	40	20	20	40
240	DKU 240/10	WOKFC2400001001	DKUS 240/10	WOKFZ2400001001	10	50	29	21,5	10,5	42	14	13	40
240	DKU 240/12	WOKFC2400001201	DKUS 240/12	WOKFZ2400001201	10	50	29	21,5	13	42	14	13	40
240	DKU 240/14	WOKFC2400001401	DKUS 240/14	WOKFZ2400001401	10	50	29	21,5	15	42	17	16	40
240	DKU 240/16	WOKFC2400001601	DKUS 240/16	WOKFZ2400001601	10	50	29	21,5	17	42	17	16	40
240	DKU 240/20	WOKFC2400002001	DKUS 240/20	WOKFZ2400002001	10	50	29	21,5	21	45	20	20	40

DKUS terminals are available on request, upon request.

Angular copper cable terminals 90° - type KP, KPS

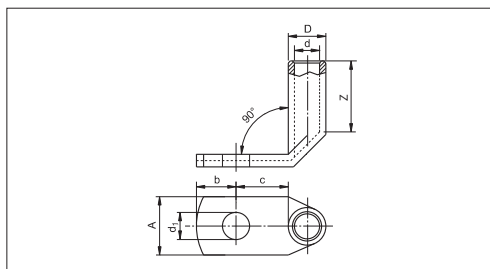

KP - Angular 90°, without galvanic coating
KPS - Tinned angular cable terminals 90°

Application

For termination of round and sector shape copper conductors for voltage up to 1kV.
They increase the safety and life of connection.

Assembling

In order to make the durable assembling of terminal, it should be pressed by using the suitable press (in case of sector cores - the core should be first formed round).

Technical data

Material: copper pipes and bars of grade Cu-ETP acc. with PN PN-EN 13600, PN-EN 13601.
KPS terminals have electroplated protective tin coatings.

Core cross sect. [mm ²]	Type of terminals	Index	Type of terminals	Index	Pack. [pcs.]	C. pac. [pcs.]	Dimensions [mm]						
							D	d	d ₁	A	b	c	z
16	KP 16/8	WOKKC0160000801	KPS 16/8	WOKKZ0160000801	50	800	8,5	5,5	8,5	14,5	10	10	13
25	KP 25/8.	WOKKC0250000801	KPS 25/8.	WOKKZ0250000801	50	500	10	7	8,5	16	10	10	16
25	KP 25/12	WOKKC0250001201	KPS 25/12	WOKKZ0250001201	50	500	10	7	13	18	12,5	14	16
35	KP 35/6	WOKKC0350000601	KPS 35/6	WOKKZ0350000601	50	300	12	8,5	6,5	18	7,5	8	17
35	KP 35/8.	WOKKC0350000801	KPS 35/8.	WOKKZ0350000801	50	300	12	8,5	8,5	18	10	11	17
35	KP 35/12	WOKKC0350001201	KPS 35/12	WOKKZ0350001201	50	300	12	8,5	13	20	12,5	13,5	17
50	KP 50/8	WOKKC0500000801	KPS 50/8	WOKKZ0500000801	20	240	14	10	8,5	20	11	11	20
50	KP 50/10.	WOKKC0500001001	KPS 50/10.	WOKKZ0500001001	20	240	14	10	11	20	12,5	12,5	20
50	KP 50/12	WOKKC0500001201	KPS 50/12	WOKKZ0500001201	20	240	14	10	13	21	12,5	13,5	20
70	KP 70/8	WOKKC0700000801	KPS 70/8	WOKKZ0700000801	20	200	16,5	12,1	8,5	23	11	11	21
70	KP 70/10.	WOKKC0700001001	KPS 70/10.	WOKKZ0700001001	20	200	16,5	12,1	11	23	12,5	12,5	21
70	KP 70/12	WOKKC0700001201	KPS 70/12	WOKKZ0700001201	20	200	16,5	12,1	13	23	12,5	13,5	21
95	KP 95/10.	WOKKC0950001001	KPS 95/10.	WOKKZ0950001001	20	140	18	13,6	11	26	12,5	12,5	23,5
95	KP 95/12	WOKKC0950001201	KPS 95/12	WOKKZ0950001201	20	140	18	13,6	13	26	12,5	13,5	23,5
95	KP 95/16	WOKKC0950001601	KPS 95/16	WOKKZ0950001601	20	140	18	13,6	17	28	17	17	23,5
120	KP 120/10	WOKKC1200001001	KPS 120/10	WOKKZ1200001001	10	100	19,5	15,1	11	29	12,5	12,5	26
120	KP 120/12.	WOKKC1200001201	KPS 120/12.	WOKKZ1200001201	10	100	19,5	15,1	13	29	12,5	13,5	26
120	KP 120/16	WOKKC1200001601	KPS 120/16	WOKKZ1200001601	10	100	19,5	15,1	17	30	17	17	26
150	KP 150/12.	WOKKC1500001201	KPS 150/12.	WOKKZ1500001201	10	80	21	16,5	13	31	12,5	13,5	30
150	KP 150/16	WOKKC1500001601	KPS 150/16	WOKKZ1500001601	10	80	21	16,5	17	31	17	17	30
185	KP 185/12	WOKKC1850001201	KPS 185/12	WOKKZ1850001201	10	50	24	19	13	35	12,5	13,5	30
185	KP 185/16.	WOKKC1850001601	KPS 185/16.	WOKKZ1850001601	10	50	24	19	17	35	17	17	30
240	KP 240/12	WOKKC2400001201	KPS 240/12	WOKKZ2400001201	10	50	26	21	13	38	12,5	13,5	35
240	KP 240/16.	WOKKC2400001601	KPS 240/16.	WOKKZ2400001601	10	50	26	21	17	38	17	17	35

Angular copper cable terminals 90°, voltage up to 30kV, acc. to DIN standard - type DKP, DKPS

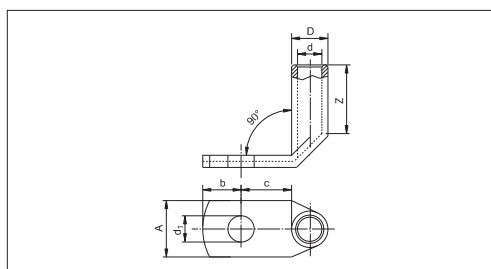

DKP - Angular 90°, acc. to DIN standard without galvanic coating
DKPS - Tinned angular 90°, acc. to DIN standard

Application

For termination of round and sector shape copper conductors for voltage up to 30kV. They increase the safety and life of connection.

Assembling

In order to make the durable assembling of terminal, it should be pressed by using the suitable press (in case of sector cores - the core should be first formed round).

Technical data

Dimensions of the tubing in accordance with DIN 46235.

Material: copper pipes of grade Cu-ETP acc. with PN PN-EN 13600, PN-EN 13601.

DKPS terminals have electroplated protective tin coatings.

Core cross sect. [mm ²]	Type of terminals	Index	Type of terminals	Index	Pack. [pcs.]	C. pac. [pcs.]	Dimensions [mm]						
							D	d	d ₁	A	b	c	z
16	DKP 16/5	WOKGC0160000501	DKPS 16/5	WOKGZ0160000501	50	800	8,5	5,5	5,5	13	7	6	20
16	DKP 16/6.	WOKGC0160000601	DKPS 16/6.	WOKGZ0160000601	50	800	8,5	5,5	6,5	13	8,5	8	20
16	DKP 16/8	WOKGC0160000801	DKPS 16/8	WOKGZ0160000801	50	800	8,5	5,5	8,5	13	11	10	20
16	DKP 16/10	WOKGC0160001001	DKPS 16/10	WOKGZ0160001001	50	800	8,5	5,5	10,5	17	13	12	20
25	DKP 25/6	WOKGC0250000601	DKPS 25/6	WOKGZ0250000601	50	500	10	7	6,5	14	8,5	8	20
25	DKP 25/8.	WOKGC0250000801	DKPS 25/8.	WOKGZ0250000801	50	500	10	7	8,5	16	11	10	20
25	DKP 25/10	WOKGC0250001001	DKPS 25/10	WOKGZ0250001001	50	500	10	7	10,5	17	13	12	20
25	DKP 25/12	WOKGC0250001201	DKPS 25/12	WOKGZ0250001201	50	500	10	7	13	19	14	13	20
35	DKP 35/6	WOKGC0350000601	DKPS 35/6	WOKGZ0350000601	50	300	12,5	8,2	6,5	17	8,5	8	20
35	DKP 35/8.	WOKGC0350000801	DKPS 35/8.	WOKGZ0350000801	50	300	12,5	8,2	8,5	17	11	10	20
35	DKP 35/10	WOKGC0350001001	DKPS 35/10	WOKGZ0350001001	50	300	12,5	8,2	10,5	19	13	12	20
35	DKP 35/12	WOKGC0350001201	DKPS 35/12	WOKGZ0350001201	50	300	12,5	8,2	13	21	14	13	20
50	DKP 50/8	WOKGC0500000801	DKPS 50/8	WOKGZ0500000801	20	240	14,5	10	8,5	20	11	10	28
50	DKP 50/10.	WOKGC0500001001	DKPS 50/10.	WOKGZ0500001001	20	240	14,5	10	10,5	22	13	12	28
50	DKP 50/12	WOKGC0500001201	DKPS 50/12	WOKGZ0500001201	20	240	14,5	10	13	24	14	13	28
50	DKP 50/14	WOKGC0500001401	DKPS 50/14	WOKGZ0500001401	20	240	14,5	10	15	28	17	16	28
50	DKP 50/16	WOKGC0500001601	DKPS 50/16	WOKGZ0500001601	20	240	14,5	10	17	28	17	16	28
70	DKP 70/8	WOKGC0700000801	DKPS 70/8	WOKGZ0700000801	20	200	16,5	11,5	8,5	24	11	10	28
70	DKP 70/10.	WOKGC0700001001	DKPS 70/10.	WOKGZ0700001001	20	200	16,5	11,5	10,5	24	13	12	28
70	DKP 70/12	WOKGC0700001201	DKPS 70/12	WOKGZ0700001201	20	200	16,5	11,5	13	24	14	13	28
70	DKP 70/14	WOKGC0700001401	DKPS 70/14	WOKGZ0700001401	20	200	16,5	11,5	15	30	17	16	28
70	DKP 70/16	WOKGC0700001601	DKPS 70/16	WOKGZ0700001601	20	200	16,5	11,5	17	30	17	16	28
95	DKP 95/8	WOKGC0950000801	DKPS 95/8	WOKGZ0950000801	20	140	19	13,5	8,5	28	11	10	35
95	DKP 95/10.	WOKGC0950001001	DKPS 95/10.	WOKGZ0950001001	20	140	19	13,5	10,5	28	13	12	35
95	DKP 95/12	WOKGC0950001201	DKPS 95/12	WOKGZ0950001201	20	140	19	13,5	13	28	14	13	35
95	DKP 95/14	WOKGC0950001401	DKPS 95/14	WOKGZ0950001401	20	140	19	13,5	15	32	17	16	35
95	DKP 95/16	WOKGC0950001601	DKPS 95/16	WOKGZ0950001601	20	140	19	13,5	17	32	17	16	35
120	DKP 120/8	WOKGC1200000801	DKPS 120/8	WOKGZ1200000801	10	100	21	15,5	8,5	32	11	10	35
120	DKP 120/10	WOKGC1200001001	DKPS 120/10	WOKGZ1200001001	10	100	21	15,5	10,5	32	13	12	35
120	DKP 120/12.	WOKGC1200001201	DKPS 120/12.	WOKGZ1200001201	10	100	21	15,5	13	32	14	13	35
120	DKP 120/14	WOKGC1200001401	DKPS 120/14	WOKGZ1200001401	10	100	21	15,5	15	32	17	16	35
120	DKP 120/16	WOKGC1200001601	DKPS 120/16	WOKGZ1200001601	10	100	21	15,5	17	32	17	16	35
120	DKP 120/20	WOKGC1200002001	DKPS 120/20	WOKGZ1200002001	10	100	21	15,5	21	38	20	20	35
150	DKP 150/10	WOKGC1500001001	DKPS 150/10	WOKGZ1500001001	10	80	23,5	17	10,5	34	13	12	35
150	DKP 150/12.	WOKGC1500001201	DKPS 150/12.	WOKGZ1500001201	10	80	23,5	17	13	34	14	13	35
150	DKP 150/14	WOKGC1500001401	DKPS 150/14	WOKGZ1500001401	10	80	23,5	17	15	34	17	16	35

Angular copper cable terminals 90°, voltage up to 30kV, acc. to DIN standard - type DKP, DKPS - continued

Core cross sect. [mm ²]	Type of terminals	Index	Type of terminals	Index	Pack. [pcs.]	C. pac. [pcs.]	Dimensions [mm]						
							D	d	d ₁	A	b	c	z
150	DKP 150/16	WOKGC1500001601	DKPS 150/16	WOKGZ1500001601	10	80	23,5	17	17	34	17	16	35
150	DKP 150/20	WOKGC1500002001	DKPS 150/20	WOKGZ1500002001	10	80	23,5	17	21	40	20	20	35
185	DKP 185/10	WOKGC1850001001	DKPS 185/10	WOKGZ1850001001	10	50	25,5	19	10,5	37	13	12	40
185	DKP 185/12	WOKGC1850001201	DKPS 185/12	WOKGZ1850001201	10	50	25,5	19	13	37	14	13	40
185	DKP 185/14	WOKGC1850001401	DKPS 185/14	WOKGZ1850001401	10	50	25,5	19	15	37	17	16	40
185	DKP 185/16	WOKGC1850001601	DKPS 185/16	WOKGZ1850001601	10	50	25,5	19	17	37	17	16	40
185	DKP 185/20	WOKGC1850002001	DKPS 185/20	WOKGZ1850002001	10	50	25,5	19	21	40	20	20	40
240	DKP 240/10	WOKGC2400001001	DKPS 240/10	WOKGZ2400001001	10	50	29	21,5	10,5	42	14	13	40
240	DKP 240/12	WOKGC2400001201	DKPS 240/12	WOKGZ2400001201	10	50	29	21,5	13	42	14	13	40
240	DKP 240/14	WOKGC2400001401	DKPS 240/14	WOKGZ2400001401	10	50	29	21,5	15	42	17	16	40
240	DKP 240/16	WOKGC2400001601	DKPS 240/16	WOKGZ2400001601	10	50	29	21,5	17	42	17	16	40
240	DKP 240/20	WOKGC2400002001	DKPS 240/20	WOKGZ2400002001	10	50	29	21,5	21	45	20	20	40

DKPS terminals are available on request, upon request.

Insulated tinned spade terminals - type VI

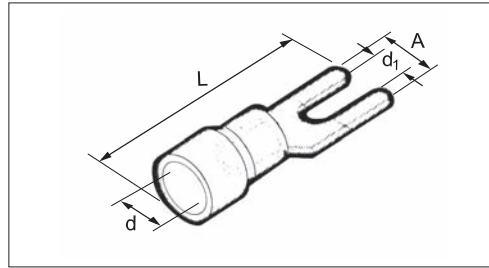

Application For termination copper conductors for voltage up to 500kV.
They increase the safety and durability of the connection.

Assembling To permanently fix the end, it should be pressed using properly selected press jaws.

Technical data Material: Copper plate, tinned-plated, PVC insulation.
Permissible operating temperature 70°C.

Core cross section [mm ²]	Type of terminals	Index	Packing [pcs.]	Cumulative packing [pcs.]	Dimensions [mm]				Insulation colour
					d ₁	d	L	A	
0,5 ÷ 1,5	VI 1 / 3	TOKLJ0010000301	100	10	3,2	4,0	22,5	5,7	red
0,5 ÷ 1,5	VI 1 / 4	TOKLJ0010000401	100	10	4,3	4,0	22,5	6,4	red
0,5 ÷ 1,5	VI 1 / 5	TOKLJ0010000501	100	10	5,3	4,0	22,5	8,0	red
1,5 ÷ 2,5	VI 2,5 / 3	TOKLJ0020000301	100	10	3,2	4,5	22,5	5,7	red
1,5 ÷ 2,5	VI 2,5 / 4	TOKLJ0020000401	100	10	4,3	4,5	22,5	6,4	blue
1,5 ÷ 2,5	VI 2,5 / 5	TOKLJ0020000501	100	10	5,3	4,5	22,5	8,0	blue
1,5 ÷ 2,5	VI 2,5 / 6	TOKLJ0020000601	100	10	6,4	4,5	22,5	10,7	blue
4 ÷ 6	VI 6 / 3	TOKLJ0060000301	100	10	3,2	6,3	25,5	7,3	blue
4 ÷ 6	VI 6 / 4	TOKLJ0060000401	100	10	4,3	6,3	25,5	8,2	yellow
4 ÷ 6	VI 6 / 5	TOKLJ0060000501	100	10	5,3	6,3	25,5	9,0	yellow
4 ÷ 6	VI 6 / 6	TOKLJ0060000601	100	10	6,4	6,3	25,5	12,0	yellow

Ring terminals - type LG, LS

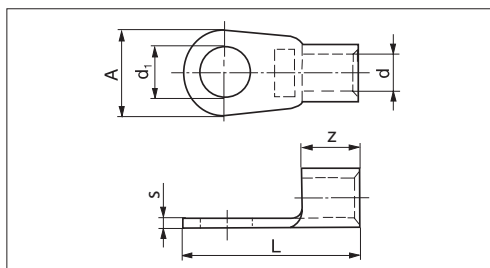

LG - Ring terminals without galvanic coating
LS - Tinned ring terminals

- Application** For termination of cables with highly flexible copper wires. They increase the safety and durability of the connection.
- Assembling** The tips have cuts for easy soldering to a highly flexible cable conductor, which is the most effective solution for this type of conductors. The terminal may be permanently fixed to low flexibility or solid conductors by pressing, using properly selected press jaws.
- Technical data** Material: Copper sheet.
LS terminals have electroplated protective tin coatings.

Core cross section [mm ²]	Type of terminals	Index	Type of terminals	Index	Packing [pcs.]	C. pac. [pcs.]	Dimensions [mm]					
							d	d ₁	s	z	L	A
4 ÷ 6	LG 6 / 5	WOKMC0060000501	LS 6 / 5	WOKMZ0060000501	100	6000	3,6	5,5	1	6	20,0	10
10	LG 10 / 6	WOKMC0100000601	LS 10 / 6	WOKMZ0100000601	100	4500	4,3	6,5	1,2	8	22,5	11
16	LG 16 / 6	WOKMC0160000601	LS 16 / 6	WOKMZ0160000601	50	2500	5,8	6,5	1,2	10	29,0	14
16	LG 16 / 8	WOKMC0160000801	LS 16 / 8	WOKMZ0160000801	50	2500	5,8	8,5	1,2	10	29,0	14
25	LG 25 / 6	WOKMC0250000601	LS 25 / 6	WOKMZ0250000601	50	1300	7,5	6,5	1,5	11	35,0	18
25	LG 25 / 8	WOKMC0250000801	LS 25 / 8	WOKMZ0250000801	50	1300	7,5	11,0	1,5	11	35,0	18
25	LG 25 / 10	WOKMC0250001001	LS 25 / 10	WOKMZ0250001001	50	1300	7,5	11,0	1,5	11	35,0	18
35	LG 35 / 6	WOKMC0350000601	LS 35 / 6	WOKMZ0350000601	50	1000	9,2	6,5	1,5	12	36,0	18
35	LG 35 / 8	WOKMC0350000801	LS 35 / 8	WOKMZ0350000801	50	1000	9,2	8,5	1,5	12	36,0	18
35	LG 35 / 10	WOKMC0350001001	LS 35 / 10	WOKMZ0350001001	50	1000	9,2	11,0	1,5	12	36,0	18
50	LG 50 / 8	WOKMC0500000801	LS 50 / 8	WOKMZ0500000801	20	500	11,0	8,5	1,8	16	47,0	22
50	LG 50 / 10	WOKMC0500001001	LS 50 / 10	WOKMZ0500001001	20	500	11,0	11,0	1,8	16	47,0	22
50	LG 50 / 12	WOKMC0500001201	LS 50 / 12	WOKMZ0500001201	20	500	11,0	13,0	1,8	16	47,0	22
70	LG 70 / 10	WOKMC0700001001	LS 70 / 10	WOKMZ0700001001	20	300	13,0	11,0	2	18	49,0	22
70	LG 70 / 12	WOKMC0700001201	LS 70 / 12	WOKMZ0700001201	20	300	13,0	13,0	2	18	49,0	22
95	LG 95 / 8	WOKMC0950000801	LS 95 / 8	WOKMZ0950000801	20	200	14,6	8,5	2,5	20	54,5	27
95	LG 95 / 10	WOKMC0950001001	LS 95 / 10	WOKMZ0950001001	20	200	14,6	11,0	2,5	20	54,5	27
95	LG 95 / 12	WOKMC0950001201	LS 95 / 12	WOKMZ0950001201	20	200	14,6	13,0	2,5	20	54,5	27

Tinned and soldered ring terminals - type LZ

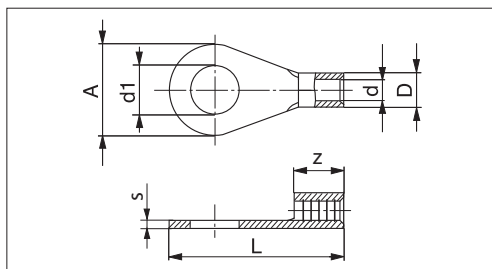

Application For termination copper conductors for voltage up to 1kV.
They increase the safety and durability of the connection.

Assembling To permanently fix the end, it should be pressed using properly selected press jaws.

Technical data Material: Copper plate, tinned-plated.

Core cross section [mm ²]	Type of terminals	Index	Packing [pcs.]	C. pac. [pcs.]	Dimensions [mm]						
					D	d	d ₁	s	z	L	A
0,5 ÷ 1,5	LZ 1 / 4	TOKMZ0010000401	100	10	3,4	1,7	4,3	0,8	4,5	14,4	6,5
0,5 ÷ 1,5	LZ 1 / 5	TOKMZ0010000501	100	10	3,4	1,7	5,3	0,8	5,0	18,3	10
1,5 ÷ 2,5	LZ 2,5 / 4	TOKMZ0020000401	100	10	4	2,3	4,3	0,8	4,8	16,8	8,5
1,5 ÷ 2,5	LZ 2,5 / 5	TOKMZ0020000501	100	10	4	2,3	5,3	0,8	4,8	16,8	9,5
1,5 ÷ 2,5	LZ 2,5 / 6	TOKMZ0020000601	100	10	4	2,3	6,4	0,8	4,8	21,8	12
1,5 ÷ 2,5	LZ 2,5 / 8	TOKMZ0020000801	100	10	4	2,3	8,4	0,8	4,8	21,8	12
1,5 ÷ 2,5	LZ 2,5 / 10	TOKMZ0020001001	100	10	4	2,3	10,5	0,8	4,8	25,4	13,6
4 ÷ 6	LZ 6 / 4	TOKMZ0060000401	100	10	5,6	3,5	4,3	1	6,8	19,8	9,5
4 ÷ 6	LZ 6 / 5	TOKMZ0060000501	100	10	5,6	3,5	5,3	1	6,8	19,8	9,5
4 ÷ 6	LZ 6 / 6	TOKMZ0060000601	100	10	5,6	3,5	6,4	1	6,8	25,8	12
4 ÷ 6	LZ 6 / 8	TOKMZ0060000801	100	10	5,6	3,5	8,4	1	6,8	28	15
10	LZ 10 / 5	TOKMZ0100000501	100	5	7	4,5	5,3	1,1	8	21	10
10	LZ 10 / 6	TOKMZ0100000601	100	5	7	4,5	6,4	1,1	8	22,5	10,8
10	LZ 10 / 8	TOKMZ0100000801	100	5	7	4,5	8,4	1,1	8	27	14
16	LZ 16 / 6	TOKMZ0160000601	100	5	8,5	5,8	6,4	1,2	11	25,5	11
16	LZ 16 / 8	TOKMZ0160000801	100	5	8,5	5,8	8,4	1,2	11	31	14
16	LZ 16 / 10	TOKMZ0160001001	100	5	8,5	5,8	10,5	1,2	11	33	18
16	LZ 16 / 12	TOKMZ0160001201	100	5	8,5	5,8	12,5	1,2	11	37	22
25	LZ 25 / 6	TOKMZ0250000601	100	5	11	7,5	6,4	1,5	11	31	12
25	LZ 25 / 8	TOKMZ0250000801	100	5	11	7,5	8,4	1,5	11	34	16
25	LZ 25 / 10	TOKMZ0250001001	100	5	11	7,5	10,5	1,5	11	35	18
35	LZ 35 / 8	TOKMZ0350000801	100	5	12,2	9	8,4	1,6	12	34	16
35	LZ 35 / 10	TOKMZ0350001001	100	5	12,2	9	10,5	1,6	12	36	15,5
35	LZ 35 / 12	TOKMZ0350001201	100	5	12,2	9	12,5	1,6	12	42	22

Insulated tinned ring terminals - type LI

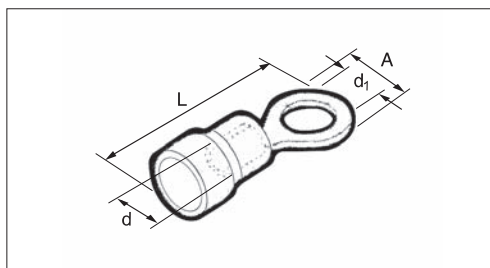
**Application**

For termination copper conductors.
They increase the safety and durability of the connection.

Assembling

To permanently fix the end, it should be pressed using properly selected press jaws.

Technical data

Material: Copper plate, tinned-plated.
For sections up to 6 mm² PVC insulation, up to 500V, permissible working temperature 70°C.
For cross-sections from 10 mm², polyamide and polycarbonate insulation, permissible working temperature 105°C.

Core cross section [mm ²]	Type of terminals	Index	Packing [pcs.]	C. pac. [pcs.]	Dimensions [mm]				Insulation colour
					d	d ₁	L	A	
0,5 ÷ 1,5	LI 1 / 3	TOKMJ0010000301	100	10	1,6	3,3	19,0	6,0	red
0,5 ÷ 1,5	LI 1 / 4	TOKMJ0010000401	100	10	1,6	4,3	21,0	8,0	red
0,5 ÷ 1,5	LI 1 / 5	TOKMJ0010000501	100	10	1,6	5,3	23,0	10,0	red
0,5 ÷ 1,5	LI 1 / 6	TOKMJ0010000601	100	10	1,6	6,4	23,0	10,0	red
0,5 ÷ 1,5	LI 1 / 8	TOKMJ0010000801	100	10	1,6	8,4	29,0	14,0	red
0,5 ÷ 1,5	LI 1 / 10	TOKMJ0010001001	100	10	1,6	10,5	29,0	14,0	red
1,5 ÷ 2,5	LI 2,5 / 3	TOKMJ0020000301	100	10	2,3	3,2	19,0	6,0	blue
1,5 ÷ 2,5	LI 2,5 / 4	TOKMJ0020000401	100	10	2,3	4,3	21,0	8,0	blue
1,5 ÷ 2,5	LI 2,5 / 5	TOKMJ0020000501	100	10	2,3	5,3	24,0	10,0	blue
1,5 ÷ 2,5	LI 2,5 / 6	TOKMJ0020000601	100	10	2,3	6,4	26,5	11,0	blue
1,5 ÷ 2,5	LI 2,5 / 8	TOKMJ0020000801	100	10	2,3	8,4	29,0	14,0	blue
1,5 ÷ 2,5	LI 2,5 / 10	TOKMJ0020001001	100	10	2,3	10,5	29,5	15,0	blue
1,5 ÷ 2,5	LI 2,5 / 12	TOKMJ0020001201	100	10	2,3	13,0	34,0	18,0	blue
4 ÷ 6	LI 6 / 3	TOKMJ0060000301	100	10	3,6	3,3	25,0	6,0	yellow
4 ÷ 6	LI 6 / 4	TOKMJ0060000401	100	10	3,6	4,3	25,0	8,0	yellow
4 ÷ 6	LI 6 / 5	TOKMJ0060000501	100	10	3,6	5,3	27,0	10,0	yellow
4 ÷ 6	LI 6 / 6	TOKMJ0060000601	100	10	3,6	6,4	28,5	11,0	yellow
4 ÷ 6	LI 6 / 8	TOKMJ0060000801	100	10	3,6	8,4	33,0	14,0	yellow
4 ÷ 6	LI 6 / 10	TOKMJ0060001001	100	10	3,6	10,5	37,0	18,0	yellow
4 ÷ 6	LI 6 / 12	TOKMJ0060001201	100	10	3,6	13,0	37,0	18,0	yellow
10	LI 10 / 6	TOKMJ0100000601	100	10	4,5	6,4	31,0	11,0	red
10	LI 10 / 8	TOKMJ0100000801	100	10	4,5	8,4	35,5	14,0	red
10	LI 10 / 10	TOKMJ0100001001	100	10	4,5	10,5	38,5	18,0	red
10	LI 10 / 12	TOKMJ0100001201	100	10	4,5	13,0	42,5	22,0	red
16	LI 16 / 6	TOKMJ0160000601	100	5	5,8	6,4	37,0	11,0	blue
16	LI 16 / 8	TOKMJ0160000801	100	5	5,8	8,4	40,5	14,0	blue
16	LI 16 / 10	TOKMJ0160001001	100	5	5,8	10,5	44,5	18,0	blue
16	LI 16 / 12	TOKMJ0160001201	100	5	5,8	13,0	48,5	22,0	blue
25	LI 25 / 8	TOKMJ0250000801	100	5	7,5	8,4	46,0	16,0	yellow
25	LI 25 / 10	TOKMJ0250001001	100	5	7,5	10,5	48,0	18,0	yellow
25	LI 25 / 12	TOKMJ0250001201	100	5	7,5	13,0	55,0	22,0	yellow
35	LI 35 / 8	TOKMJ0350000801	100	5	9,0	8,4	49,0	16,0	red
35	LI 35 / 10	TOKMJ0350001001	100	5	9,0	10,5	51,0	18,0	red
35	LI 35 / 12	TOKMJ0350001201	100	5	9,0	13,0	57,0	22,0	red

Partially insulated tinned female connectors - type JB

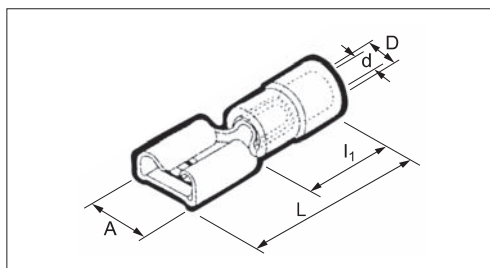

Application	For connection copper conductors.
Assembling	To permanently fix the end, it should be pressed using properly selected press jaws.
Technical data	Material: Galvanized brass plate, PCV insulated. Permissible voltage 300 V. Working temperature up to 70°C.

Core cross section [mm ²]	Type of terminals	Index	Packing [pcs.]	Dimensions [mm]					Insulation colour
				D	d	l ₁	L	A	
0,5 ÷ 1,5	JB 2,8 - 1 - 0,8	TOKNJ0010002802	100	3,5	1,8	9,7	18,5	3,0	red
0,5 ÷ 1,5	JB 4,8 - 1 - 0,8	TOKNJ0010004802	100	3,5	1,8	9,7	19,0	5,0	red
0,5 ÷ 1,5	JB 6,3 - 1 - 0,8	TOKNJ0010006302	100	3,5	1,8	9,7	20,5	6,8	red
1,5 ÷ 2,5	JB 2,8 - 2,5 - 0,8	TOKNJ0020002802	100	4,0	2,3	9,7	18,5	3,0	blue
1,5 ÷ 2,5	JB 4,8 - 2,5 - 0,8	TOKNJ0020004802	100	4,0	2,3	9,7	19,0	5,0	blue
1,5 ÷ 2,5	JB 6,3 - 2,5 - 0,8	TOKNJ0020006302	100	4,0	2,3	9,7	20,5	6,8	blue
4 ÷ 6	JB 6,3 - 6 - 0,8	TOKNJ0060006302	100	5,4	3,5	13,7	24,5	6,8	yellow

Fully insulated tinned female connectors - type JC

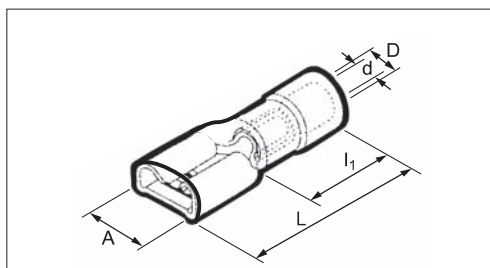

Application For termination copper conductors.

Assembling To permanently fix the end, it should be pressed using properly selected press jaws.

Technical data Material: Brass sheet, tinned-plated, PVC insulation.
Permissible voltage 300V.
Operating temperature 70°C.

Core cross section [mm ²]	Type of terminals	Indeks	Pakow. [szt.]	Wymiary [mm]					Insulation colour
				D	d	I ₁	L	A	
1,5 ÷ 2,5	JC 6,3 - 2,5 - 0,8	TOKNI0020006302	100	4,0	2,3	10	23,5	6,8	blue
4 ÷ 6	JC 6,3 - 6 - 0,8	TOKNI0060006302	100	5,4	3,5	11	24,0	6,8	yellow

Partially insulated tinned male connectors - type JE

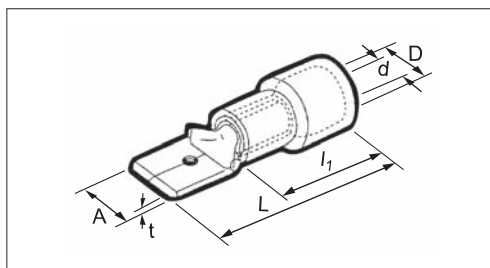

Application For connection copper conductors.

Assembling To permanently fix the end, it should be pressed using properly selected press jaws.

Technical data Material: Galvanized brass plate, PCV insulated.
Permissible voltage 300 V.
Working temperature up to 70°C.

Core cross section [mm ²]	Type of terminals	Index	Packing [pcs.]	Dimensions [mm]							Insulation colour
				D	d	I ₁	L	A	t		
0,5 ÷ 1,5	JE 2,8 - 1 - 0,8	TOKWJ0010002802	100	3,5	1,8	9,7	18,5	2,8	0,8	red	
0,5 ÷ 1,5	JE 4,8 - 1 - 0,8	TOKWJ0010004802	100	3,5	1,8	9,7	19,0	4,8	0,8	red	
1,5 ÷ 2,5	JE 4,8 - 2,5 - 0,8	TOKWJ0020004802	100	4,0	2,3	9,7	19,0	4,8	0,8	blue	
4 ÷ 6	JE 6,3 - 6 - 0,8	TOKWJ0060006302	100	5,4	3,5	13,7	24,5	6,3	0,8	yellow	

Partially insulated tinned piggyback connectors - type JF

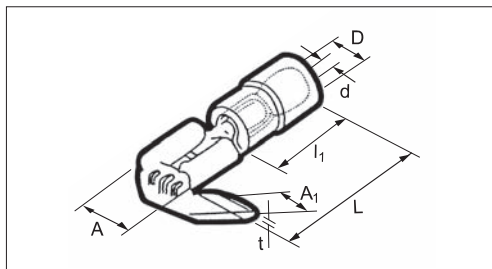

- Application** For termination copper conductors.
- Assembling** To permanently fix the end, it should be pressed using properly selected press jaws.
- Technical data** Material: Brass sheet, tinned-plated, PVC insulation.
Permissible voltage 300V.
Operating temperature 70°C

Core cross section [mm ²]	Type of terminals	Index	Packing [pcs.]	Dimensions [mm]			Dimensions [mm]				Insulation colour
				D	d	l ₁	L	A	A ₁	t	
0,5 ÷ 1,5	JF 6,3 - 1 - 0,8	TOKWJ0060006302	100	3,9	1,8	10,0	22,0	6,8	6,3	0,8	red
1,5 ÷ 2,5	JF 6,3 - 2,5 - 0,8	TOKPJ0010006302	100	4,2	2,3	10,0	22,0	6,8	6,3	0,8	blue

Total-insulation cable sleeves – JP type

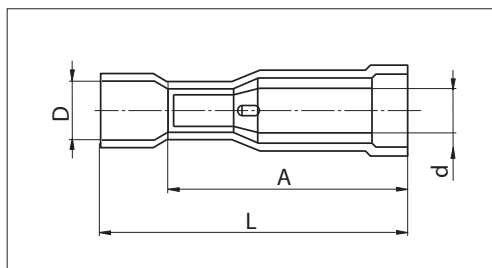
**Application**

For termination copper conductors.

They serve as an alternative to flat sleeves, allow convenient connection, lack of sharp edges, large contact area.

Assembling

To permanently fix the end, it should be pressed using properly selected press jaws.

Technical data

Material: Brass sheet, tinned-plated, PVC insulation.

Permissible voltage 300V.

Operating temperature 70°C.

Core cross section [mm ²]	Type of terminals	Index	Packing [pcs.]	Dimensions [mm]				Insulation colour
				D	d	L	A	
0,5 ÷ 1	JP 1-4	TOKRZ0010000401	100	4,0	4	21,0	15,5	red
1,5 ÷ 2,5	JP 2,5-4	TOKRZ0020000401	100	4,5	4	21,0	15,5	blue
1,5 ÷ 2,5	JP 2,5-5	TOKRZ0020000501	100	4,5	5	21,5	15,5	blue
4 ÷ 6	JP 6-5	TOKRZ0060000501	100	5,5	5	21,5	15,5	yellow

Partial-insulation cable slides - type JR

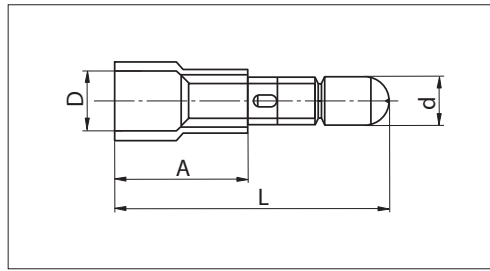
**Application**

For termination copper conductors.

They serve as an alternative to flat sleeves, allow convenient connection, lack of sharp edges, large contact area.

Assembling

To permanently fix the end, it should be pressed using properly selected press jaws.

Technical data

Brass sheet, tinned-plated, PVC insulation.

Permissible voltage 300V.

Operating temperature 70°C.

Core cross section [mm ²]	Type of terminals	Index	Packing [pcs.]	Dimensions [mm]			Insulation colour	
				D	d	L		
0,5 ÷ 1	JR 1-4	TOKTZ0010000401	100	3,8	4	23	11,5	red
1,5 ÷ 2,5	JR 2,5-4	TOKTZ0020000401	100	4,3	4	23	11,5	blue
1,5 ÷ 2,5	JR 2,5-5	TOKTZ0020000501	100	4,3	5	23	11,5	blue
4 ÷ 6	JR 6-5	TOKTZ0060000501	100	5,5	5	24	13,0	yellow

Tinned sleeving terminals, not insulated - type AS

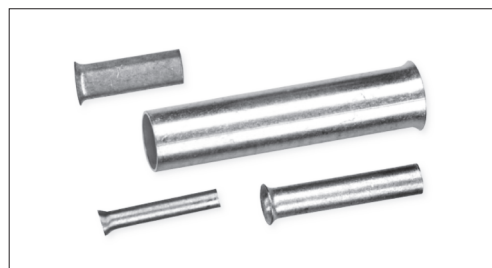
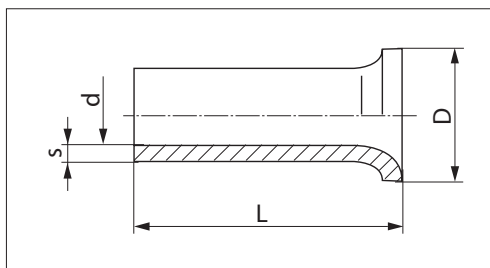
**Application**

For termination of multi-stranded copper cables in order to protect wires and improve power characteristics of contact points.
They increase the safety and durability of the connection.

Assembling

To permanently fix the end, it should be pressed using properly selected press jaws.

Technical data

Material: Copper tubes, tinned-plated.
Made according to DIN 46228 standard, part 1.

Core cross section [mm ²]	Type of terminals	Index	Packing [pcs.]	Multipack [set]	Dimensions [mm]			
					s	d	D	L
0,5	AS 0,5-8	TOKRZ0000000801	100	10	0,15	1	1,9	8
0,5	AS 0,5-10	TOKRZ0000001001	100	10	0,15	1	1,9	10
0,75	AS 0,75-6	TOKRZ0000000602	100	10	0,15	1,2	2,2	6
0,75	AS 0,75-8	TOKRZ0000000802	100	10	0,15	1,2	2,2	8
1	AS 1-6	TOKRZ0010000601	100	10	0,15	1,4	2,4	6
1	AS 1-8	TOKRZ0010000801	100	10	0,15	1,4	2,4	8
1	AS 1-10	TOKRZ0010001001	100	10	0,15	1,4	2,4	10
1,5	AS 1,5-8	TOKRZ0010000802	100	10	0,15	1,7	2,8	8
1,5	AS 1,5-10	TOKRZ0010001002	100	10	0,15	1,7	2,8	10
2,5	AS 2,5-8	TOKRZ0020000801	100	10	0,15	2,2	3,4	8
2,5	AS 2,5-10	TOKRZ0020001001	100	10	0,15	2,2	3,4	10
2,5	AS 2,5-12	TOKRZ0020001201	100	10	0,15	2,2	3,4	12
4	AS 4-10	TOKRZ0040001001	100	10	0,2	2,8	4	10
4	AS 4-12	TOKRZ0040001201	100	10	0,2	2,8	4	12
6	AS 6-12	TOKRZ0060001201	100	10	0,2	3,5	4,7	12
6	AS 6-18	TOKRZ0060001801	100	10	0,2	3,5	4,7	18
10	AS 10-12	TOKRZ0100001201	100	10	0,2	4,5	5,8	12
10	AS 10-18	TOKRZ0100001801	100	10	0,2	4,5	5,8	18
16	AS 16-12	TOKRZ0160001201	100	10	0,2	5,8	7,5	12
16	AS 16-18	TOKRZ0160001801	100	10	0,2	5,8	7,5	18
25	AS 25-22	TOKRZ0250002201	100	10	0,2	7,3	9,5	22
35	AS 35-16	TOKRZ0350001601	50	10	0,2	8,3	10,5	16
50	AS 50-20	TOKRZ0500002001	50	10	0,3	10,3	13	20

Tinned sleeving terminals, insulated - type AI

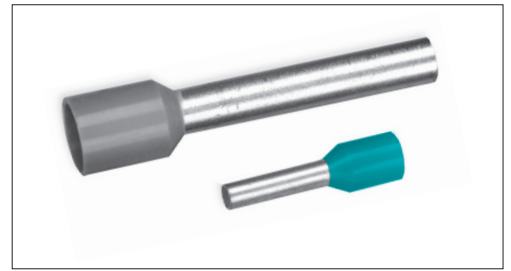
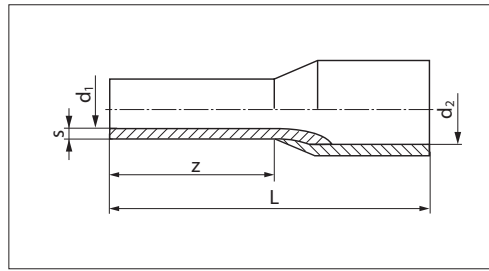
**Application**

For termination of multi-stranded copper cables in order to protect wires and improve power characteristics of contact points. They increase the safety and durability of the connection.

Assembling

In order to make the durable assembling of terminal, it should be pressed by using the suitable press.

Technical data

Material: Made according to DIN 46228 standard, part 4.
Copper tubes, tinned-plated, polyamide isolation.

Core cross section [mm ²]	Type of terminals	Index	Packing [pcs.]	Multipack [set]	Dimensions [mm]					Insulation colour
					s	d ₁	d ₂	z	L	
0,25	AI 0,25-6	TOKRJ0000000602	100	10	0,15	0,75	1,9	6	10	yellow
0,25	AI 0,25-8	TOKRJ0000000802	100	10	0,15	0,75	1,9	8	12	yellow
0,34	AI 0,34-6	TOKRJ0000000603	100	10	0,15	0,8	1,9	6	10	turquoise
0,34	AI 0,34-8	TOKRJ0000000803	100	10	0,15	0,8	1,9	8	12	turquoise
0,5	AI 0,5-6	TOKRJ0000000604	100	10	0,15	1	2,6	6	12	white
0,5	AI 0,5-8	TOKRJ0000000804	100	10	0,15	1	2,6	8	14	white
0,5	AI 0,5-10	TOKRJ0000001004	100	10	0,15	1	2,6	10	16	white
0,75	AI 0,75-6	TOKRJ0000000605	100	10	0,15	1,2	2,8	6	12	gray
0,75	AI 0,75-8	TOKRJ0000000805	100	10	0,15	1,2	2,8	8	14	gray
0,75	AI 0,75-10	TOKRJ0000001005	100	10	0,15	1,2	2,8	10	16	gray
0,75	AI 0,75-12	TOKRJ0000001205	100	10	0,15	1,2	2,8	12	18	gray
1	AI 1-6	TOKRJ0010000601	100	10	0,15	1,4	3	6	12	red
1	AI 1-8	TOKRJ0010000801	100	10	0,15	1,4	3	8	14	red
1	AI 1-10	TOKRJ0010001001	100	10	0,15	1,4	3	10	16	red
1	AI 1-12	TOKRJ0010001201	100	10	0,15	1,4	3	12	18	red
1,5	AI 1,5-8	TOKRJ0010000802	100	10	0,15	1,7	3,5	8	14	black
1,5	AI 1,5-10	TOKRJ0010001002	100	10	0,15	1,7	3,5	10	16	black
1,5	AI 1,5-12	TOKRJ0010001202	100	10	0,15	1,7	3,5	12	18	black
1,5	AI 1,5-18	TOKRJ0010001802	100	10	0,15	1,7	3,5	18	24	black
2,5	AI 2,5-8	TOKRJ0020000801	100	10	0,15	2,2	4,2	8	14	blue
2,5	AI 2,5-10	TOKRJ0020001001	100	10	0,15	2,2	4,2	10	16	blue
2,5	AI 2,5-12	TOKRJ0020001201	100	10	0,15	2,2	4,2	12	18	blue
2,5	AI 2,5-18	TOKRJ0020001801	100	10	0,15	2,2	4,2	18	24	blue
4	AI 4 - 10	TOKRJ0040001001	100	10	0,2	2,8	4,8	10	17	gray
4	AI 4 - 12	TOKRJ0040001201	100	10	0,2	2,8	4,8	12	20	gray
4	AI 4 - 18	TOKRJ0040001801	100	10	0,2	2,8	4,8	18	26	gray
6	AI 6 - 12	TOKRJ0060001201	100	10	0,2	3,5	6,3	12	20	yellow
6	AI 6 - 18	TOKRJ0060001801	100	10	0,2	3,5	6,3	18	26	yellow
10	AI 10 - 12	TOKRJ0100001201	100	10	0,2	4,5	7,6	12	22	red
10	AI 10 - 18	TOKRJ0100001801	100	10	0,2	4,5	7,6	18	28	red
16	AI 16 - 12	TOKRJ0160001201	100	10	0,2	5,8	8,8	12	24	blue
16	AI 16 - 18	TOKRJ0160001801	100	10	0,2	5,8	8,8	18	28	blue
25	AI 25 - 16	TOKRJ0250001601	100	10	0,2	7,5	11,2	16	30	yellow
25	AI 25 - 22	TOKRJ0250002201	100	10	0,2	7,5	11,2	22	36	yellow
35	AI 35 - 16	TOKRJ0350001601	50	10	0,2	8,3	12,7	16	30	red
35	AI 35 - 18	TOKRJ0350001801	50	10	0,2	8,3	12,7	18	32	red
35	AI 35 - 25	TOKRJ0350002501	50	10	0,2	8,3	12,7	25	39	red
50	AI 50 - 20	TOKRJ0500002001	50	10	0,3	10,3	15	20	36	blue
70	AI 70 - 20	TOKRJ0700002001	50	10	0,4	13,5	16	20	37	yellow
95	AI 95 - 25	TOKRJ0950002501	25	10	0,4	14,8	18,5	25	44	red
120	AI 120 - 27	TOKRJ1200002701	25	10	0,5	16,7	20,3	27	48	blue
150	AI 150 - 32	TOKRJ1500003201	25	10	0,5	19,6	23,4	32	58	yellow

Tinned double sleeving terminals, insulated - type AI 2x

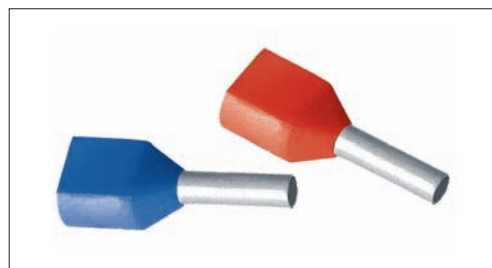
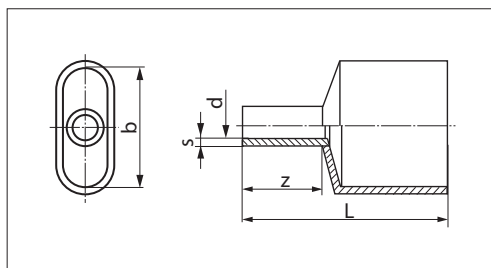

Application For pairing and crimping two multicore copper cables simultaneously.
Provides protection for cores and enhances contact performance.

Assembling To secure permanently, press with an appropriate crimping pliers.

Technical data Material: Copper pipes, tinned galvanized, polyamide insulated.

Core cross section [mm ²]	Type of terminals	Index	Packing [pcs.]	C. pac. [pcs.]	Dimensions [mm]					Insulation colour
					s	d	b	z	L	
0,5	AI 2x 0,5 - 8	TOKSJ0000000804	100	10	0,15	1,5	5	8	14,5	white
0,75	AI 2x 0,75 - 8	TOKSJ0000000805	100	10	0,15	1,8	5,5	8	14,7	gray
0,75	AI 2x 0,75 - 10	TOKSJ0000001005	100	10	0,15	1,8	5,5	10	16,7	gray
1	AI 2x 1 - 8	TOKSJ0010000801	100	10	0,15	2,1	5,5	8	15,1	red
1	AI 2x 1 - 10	TOKSJ0010001001	100	10	0,15	2,1	5,5	10	17,1	red
1,5	AI 2x 1,5 - 8	TOKSJ0010000802	100	10	0,15	2,3	6,5	8	15,5	black
1,5	AI 2x 1,5 - 12	TOKSJ0010001202	100	10	0,15	2,3	6,5	12	19,5	black
2,5	AI 2x 2,5 - 10	TOKSJ0020001001	100	10	0,2	2,9	8,0	10	18,5	blue
2,5	AI 2x 2,5 - 13	TOKSJ0020001301	100	10	0,2	2,9	8,0	13	21,5	blue
4	AI 2x 4 - 12	TOKSJ0040001201	100	10	0,2	3,8	8,6	12	23,1	gray
6	AI 2x 6 - 14	TOKSJ0060001401	100	10	0,2	4,9	9,5	14	26,1	yellow
10	AI 2x 10 - 14	TOKSJ0100001401	100	10	0,2	6,5	12,6	14	26,6	red
16	AI 2x 16 - 14	TOKSJ0160001401	100	10	0,2	8,3	19,0	14	31,3	blue

Terminals with bolts, insulated PCV, tinned - type KBI

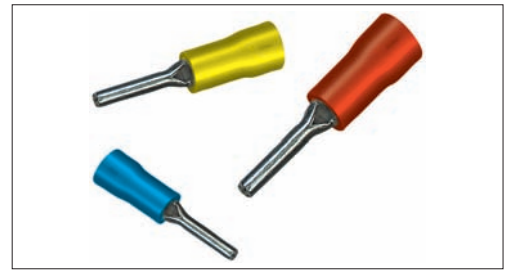
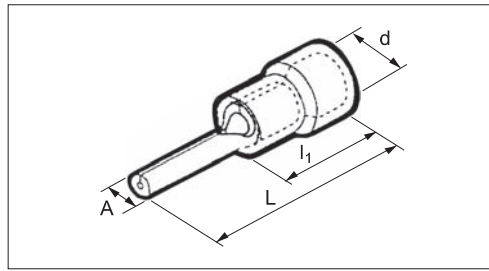

Application For termination copper conductors for voltage up to 500kV.
They increase the safety and durability of the connection.

Assembling To permanently fix the end, it should be pressed using properly selected press jaws.

Technical data Material: Copper tubes, tinned-plated, PCV isolation.
Operating temperature 70°C.

Core cross section [mm ²]	Type of terminals	Index	Packing [pcs.]	Dimensions [mm]				Insulation colour
				d	l ₁	L	A	
0,5 ÷ 1,5	KBI 1	TOKTJ0010000001	100	4,0	10,7	22,7	2,0	red
1,5 ÷ 2,5	KBI 2,5	TOKTJ0020000001	100	4,5	10,7	22,7	2,0	blue
4 ÷ 6	KBI 6	TOKTJ0060000001	100	6,3	13,7	22,7	2,7	yellow

Copper cable ends, insulated – JK type

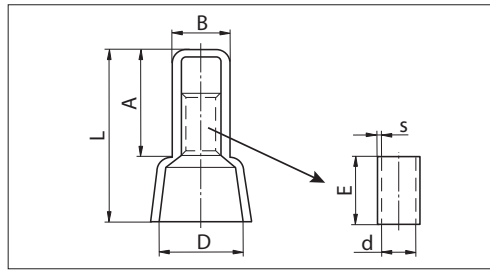

Application They are intended for quick and easy insulation of cable conductor ends, e.g. when assembling lighting or in installation boxes.

Assembling To mount the end permanently, it is necessary to press it by means of the press with well-selected jaws.

Technical data Material: tinned copper sleeve, insulation made of polyamide.
Permissible working temperature from -30 to 105°C.
Rated voltage 600V.

Core cross section [mm ²] input	Type of terminals	Index	Packing [pcs.]	Dimensions [mm]							
				D	L	A	B	E	d	s	
0,5 ÷ 1,5	JK 1	TOZBC0000000101	100	8	21,0	13,6	5,0	7,0	2,3	0,5	
1,5 ÷ 2,5	JK 2,5	TOZBC0000000251	100	8	21,0	13,9	5,5	7,0	3,1	0,5	
4 ÷ 6	JK 6	TOZBC0000000601	100	10	25,5	14,6	7,5	7,5	4,0	0,7	

Copper cable ferrules - type Z, ZS

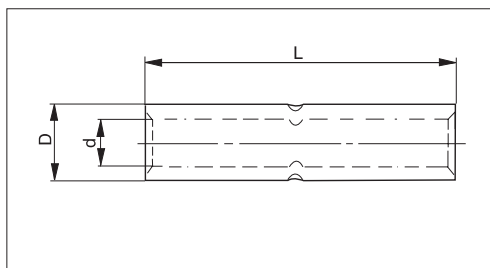

Z - without galvanic coating ZS - tinned

Application	For the termination of round copper cores and sector - shaped conductors, voltage up to 1KV. They increase the safety and life of connection.
Assembling	In order to make the durable assembling of ferrule, it should be pressed by using the suitable press (in case of sector cores - the core should be first formed round).
Technical data	Material: Cu-ETP copper pipes according to PN-EN 13600, PN-EN 13601. ZS ferrules have a tin-plated protective coating.

Core cross section [mm ²]	Type of ferrules	Index	Type of ferrules	Index	Packing [pcs.]	Cumulative packing [pcs.]	Dimensions [mm]		
							D	d	L
0,5 ÷ 1,5			ZS 1	TOZAZ0010000001	100	1000	3,7	1,8	16
1,5 ÷ 2,5	Z 2,5	TOZAC0020000001	ZS 2,5	TOZAZ0020000001	100	1000	4,0	2,4	15
4	Z 4	TOZAC0040000001	ZS 4	TOZAZ0040000001	100	1000	4,5	2,9	20
6	Z 6	TOZAC0060000001	ZS 6	TOZAZ0060000001	100	1000	5,9	4,0	25
10	Z 10	TOZAC0100000001	ZS 10	TOZAZ0100000001	100	500	6,6	4,5	30
16	Z 16	WOZAC0160000001	ZS 16	WOZAZ0160000001	50	1400	8,5	5,5	29
25	Z 25	WOZAC0250000001	ZS 25	WOZAZ0250000001	50	800	10,0	7,0	33
35	Z 35	WOZAC0350000001	ZS 35	WOZAZ0350000001	50	600	12,0	8,5	39
50	Z 50	WOZAC0500000001	ZS 50	WOZAZ0500000001	20	400	14,0	10,0	45
70	Z 70	WOZAC0700000001	ZS 70	WOZAZ0700000001	20	300	16,5	12,1	47
95	Z 95	WOZAC0950000001	ZS 95	WOZAZ0950000001	20	220	18,0	13,6	53
120	Z 120	WOZAC1200000001	ZS 120	WOZAZ1200000001	10	140	19,5	15,1	64
150	Z 150	WOZAC1500000001	ZS 150	WOZAZ1500000001	10	120	21,0	16,5	68
185	Z 185	WOZAC1850000001	ZS 185	WOZAZ1850000001	10	100	24,0	19,0	75
240	Z 240	WOZAC2400000001	ZS 240	WOZAZ2400000001	10	60	26,0	21,0	85
300	Z 300	WOZAC3000000001	ZS 300	WOZAZ3000000001	1	50	30,0	24,0	100

Copper cable ferrules acc. to DIN standard - type DZ, DZS

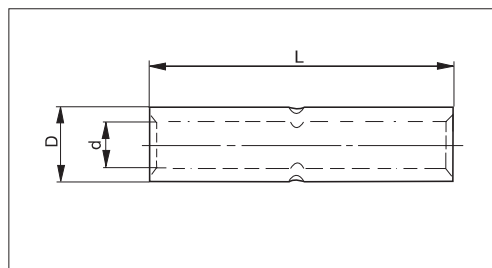

DZ - acc. to DIN standard without galvanic coating
 DZS - tinned, acc. to DIN standard

- Application** For the termination of round copper cores and sector - shaped conductors, voltage up to 6kV. They increase the safety and life of connection.
- Assembling** In order to make the durable assembling of ferrule, it should be pressed by using the suitable press (in case of sector cores - the core should be first formed round).
- Technical data** Diameters according to DIN 46267 part 1.
 Material: Copper rods in Cu-ETP grade according to EN 13600, PN-EN 13601.
 DZS ferrules have a tin-plated protective coating.

Core cross section [mm ²]	Type of ferrules	Index	Type of ferrules	Index	Packing [pcs.]	Cumulative packing [pcs.]	Dimensions [mm]		
							D	d	L
16	DZ 16	WOZCC0160000001	DZS 16	WOZCZ0160000001	50	800	8,5	5,5	50
25	DZ 25	WOZCC0250000001	DZS 25	WOZCZ0250000001	50	600	10,0	7,0	50
35	DZ 35	WOZCC0350000001	DZS 35	WOZCZ0350000001	50	400	12,5	8,2	50
50	DZ 50	WOZCC0500000001	DZS 50	WOZCZ0500000001	20	300	14,5	10,0	56
70	DZ 70	WOZCC0700000001	DZS 70	WOZCZ0700000001	20	220	16,5	11,5	56
95	DZ 95	WOZCC0950000001	DZS 95	WOZCZ0950000001	20	140	19,0	13,5	70
120	DZ 120	WOZCC1200000001	DZS 120	WOZCZ1200000001	10	120	21,0	15,5	70
150	DZ 150	WOZCC1500000001	DZS 150	WOZCZ1500000001	10	100	23,5	17,0	80
185	DZ 185	WOZCC1850000001	DZS 185	WOZCZ1850000001	10	60	25,5	19,0	85
240	DZ 240	WOZCC2400000001	DZS 240	WOZCZ2400000001	10	50	29,0	21,5	90
300	DZ 300	WOZCC3000000001	DZS 300	WOZCZ3000000001	4	12	32,0	24,5	100
400	DZ 400	WOZCC4000000001	DZS 400	WOZCZ4000000001	4	12	38,5	27,5	150
500	DZ 500	WOZCC5000000001	DZS 500	WOZCZ5000000001	4	12	42,0	31,0	160
625	DZ 625	WOZCC6250000001	DZS 625	WOZCZ6250000001	4	12	44,0	34,5	160

Copper cable ferrules with the partition acc. to DIN standard - type DZP, DZPS

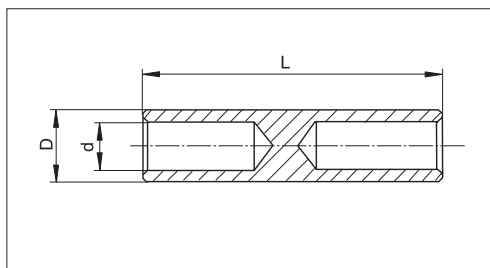

DZPZ - with the partition acc. to DIN standard without galvanic coating
DZPSZ - Tinned with the partition acc. to DIN standard

Application	For the termination of round copper cores and sector - shaped conductors, voltage up to 6kV. They increase the safety and life of connection.
Assembling	In order to make the durable assembling of ferrule, it should be pressed by using the suitable press (in case of sector cores - the core should be first formed round).
Technical data	Diameters according to DIN 46267 part 1. Material: copper pipes of Cu-ETP grade according to EN 13600, PN-EN 13601. The ferrules with the partition. DZPS ferrules have a protective galvanized tin.

Core cross section [mm ²]	Type of ferrules	Index	Type of ferrules	Index	Packing [pcs.]	Cumulative packing [pcs.]	Dimensions [mm]		
							D	d	L
16	DZP 16	WOZDC0160000001	DZPS 16	WOZDZ0160000001	4	800	8,5	5,5	53
25	DZP 25	WOZDC0250000001	DZPS 25	WOZDZ0250000001	4	600	10,0	7,0	53
35	DZP 35	WOZDC0350000001	DZPS 35	WOZDZ0350000001	4	400	12,5	8,2	53
50	DZP 50	WOZDC0500000001	DZPS 50	WOZDZ0500000001	4	300	14,5	10,0	60
70	DZP 70	WOZDC0700000001	DZPS 70	WOZDZ0700000001	4	220	16,5	11,5	60
95	DZP 95	WOZDC0950000001	DZPS 95	WOZDZ0950000001	4	140	19,0	13,5	74
120	DZP 120	WOZDC1200000001	DZPS 120	WOZDZ1200000001	4	120	21,0	15,5	74
150	DZP 150	WOZDC1500000001	DZPS 150	WOZDZ1500000001	4	100	23,5	17,0	82
185	DZP 185	WOZDC1850000001	DZPS 185	WOZDZ1850000001	4	60	25,5	19,0	87
240	DZP 240	WOZDC2400000001	DZPS 240	WOZDZ2400000001	4	50	29,0	21,5	93

DZP, DZPS ferrules are available on request.

Reducing copper cable ferrules acc. to DIN standard - type DZR, DZRS

ON REQUEST

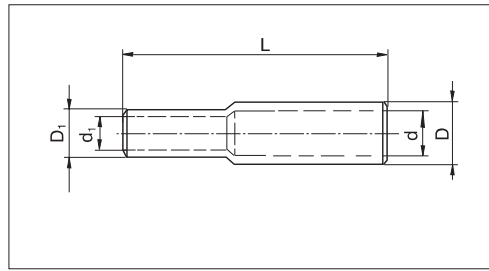

DZR - Reducing, acc. to DIN standard without galvanic coating
DZRS - Tined, reducing, acc. to DIN standard

Application	For the termination of round copper cores and sector - shaped conductors, voltage up to 6kV. They increase the safety and life of connection.
Assembling	In order to make the durable assembling of ferrule, it should be pressed by using the suitable press (in case of sector cores - the core should be first formed round).
Technical data	Diameters according to DIN 46267 part 1. Material: copper pipes and bars of Cu-ETP grade according to EN 13600, PN-EN 13601. DZRS ferrules have a protective galvanized tin.

Core cross section [mm ²] input	initial	Type of ferrules	Index	Type of ferrules	Index	Packing [pcs.]	Dimensions [mm]				
							D	D ₁	d	d ₁	L
16	10	DZR 16 / 10	WOZCC0160100001	DZRS 16 / 10	WOZCZ0160100001	4	8,5	6,0	5,5	4,5	40
25	10	DZR 25 / 10	WOZCC0250100001	DZRS 25 / 10	WOZCZ0250100001	4	10,0	6,0	7,0	4,5	40
25	16	DZR 25 / 16	WOZCC0250160001	DZRS 25 / 16	WOZCZ0250160001	4	10,0	8,5	7,0	5,5	50
35	16	DZR 35 / 16	WOZCC0350160001	DZRS 35 / 16	WOZCZ0350160001	4	12,5	8,5	8,2	5,5	50
35	25	DZR 35 / 25	WOZCC0350250001	DZRS 35 / 25	WOZCZ0350250001	4	12,5	10,0	8,2	7,0	50
50	25	DZR 50 / 25	WOZCC0500250001	DZRS 50 / 25	WOZCZ0500250001	4	14,5	10,0	10,0	7,0	55
50	35	DZR 50 / 35	WOZCC0500350001	DZRS 50 / 35	WOZCZ0500350001	4	14,5	12,5	10,0	8,2	55
70	35	DZR 70 / 35	WOZCC0700350001	DZRS 70 / 35	WOZCZ0700350001	4	16,5	12,5	11,5	8,2	55
70	50	DZR 70 / 50	WOZCC0700500001	DZRS 70 / 50	WOZCZ0700500001	4	16,5	14,5	11,5	10,0	55
95	50	DZR 95 / 50	WOZCC0950500001	DZRS 95 / 50	WOZCZ0950500001	4	19,0	14,5	13,5	10,0	70
95	70	DZR 95 / 70	WOZCC0950700001	DZRS 95 / 70	WOZCZ0950700001	4	19,0	16,5	13,5	11,5	70
120	50	DZR 120 / 50	WOZCC1200500001	DZRS 120 / 50	WOZCZ1200500001	4	21,0	14,5	15,5	10,0	70
120	70	DZR 120 / 70	WOZCC1200700001	DZRS 120 / 70	WOZCZ1200700001	4	21,0	16,5	15,5	11,5	70
120	95	DZR 120 / 95	WOZCC1200950001	DZRS 120 / 95	WOZCZ1200950001	4	21,0	19,0	15,5	13,5	70
150	70	DZR 150 / 70	WOZCC1500700001	DZRS 150 / 70	WOZCZ1500700001	4	23,5	16,5	17,0	11,5	80
150	95	DZR 150 / 95	WOZCC1500950001	DZRS 150 / 95	WOZCZ1500950001	4	23,5	19,0	17,0	13,5	80
150	120	DZR 150 / 120	WOZCC1501200001	DZRS 150 / 120	WOZCZ1501200001	4	23,5	21,0	17,0	15,5	80
185	95	DZR 185 / 95	WOZCC1850950001	DZRS 185 / 95	WOZCZ1850950001	4	25,5	19,0	19,0	13,5	85
185	120	DZR 185 / 120	WOZCC1851200001	DZRS 185 / 120	WOZCZ1851200001	4	25,5	21,0	19,0	15,5	85
185	150	DZR 185 / 150	WOZCC1851500001	DZRS 185 / 150	WOZCZ1851500001	4	25,5	23,5	19,0	17,0	85
240	120	DZR 240 / 120	WOZCC2401200001	DZRS 240 / 120	WOZCZ2401200001	4	29,0	21,0	21,5	15,5	95
240	150	DZR 240 / 150	WOZCC2401500001	DZRS 240 / 150	WOZCZ2401500001	4	29,0	23,5	21,5	17,0	95
240	185	DZR 240 / 185	WOZCC2401850001	DZRS 240 / 185	WOZCZ2401850001	4	29,0	25,5	21,5	19,0	95

DZR, DZRS ferrules are available on request.

Reducing copper cable ferrules acc. to DIN standard with leakproof partition - type DZRP, DZRPS

ON REQUEST

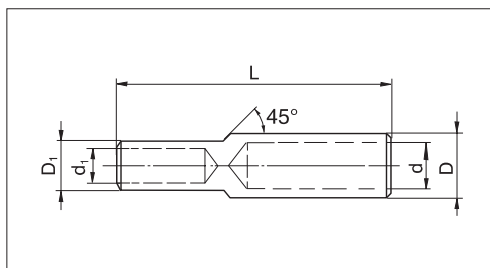

DZRPS - Reducing, acc. to DIN standard with leakproof partition, without galvanic coating

DZRP - Reducing, acc. to DIN standard with leakproof partition, tinned

Application	For the termination of round copper cores and sector - shaped conductors, voltage up to 6kV. They increase the safety and life of connection.
Assembling	In order to make the durable assembling of ferrule, it should be pressed by using the suitable press (in case of sector cores - the core should be first formed round).
Technical data	Diameters according to DIN 46267 part 1. Material: copper pipes and bars of Cu-ETP grade according to EN 13600, PN-EN 13601. DZRPS ferrules have a protective galvanized tin.

Core cross section [mm ²] input	Type of initial	Type of ferrules	Index	Type of ferrules	Index	Pack. [pcs.]	Dimensions [mm]				
							D	D ₁	d	d ₁	L
16	10	DZRP 16 / 10	WOZDC0160100001	DZRPS 16 / 10	WOZDZ0160100001	4	8,5	6,0	5,5	4,5	45
25	10	DZRP 25 / 10	WOZDC0250100001	DZRPS 25 / 10	WOZDZ0250100001	4	10,0	6,0	7,0	4,5	45
25	16	DZRP 25 / 16	WOZDC0250160001	DZRPS 25 / 16	WOZDZ0250160001	4	10,0	8,5	7,0	5,5	55
35	16	DZRP 35 / 16	WOZDC0350160001	DZRPS 35 / 16	WOZDZ0350160001	4	12,5	8,5	8,2	5,5	55
35	25	DZRP 35 / 25	WOZDC0350250001	DZRPS 35 / 25	WOZDZ0350250001	4	12,5	10,0	8,2	7,0	55
50	25	DZRP 50 / 25	WOZDC0500250001	DZRPS 50 / 25	WOZDZ0500250001	4	14,5	10,0	10,0	7,0	60
50	35	DZRP 50 / 35	WOZDC0500350001	DZRPS 50 / 35	WOZDZ0500350001	4	14,5	12,5	10,0	8,2	60
70	35	DZRP 70 / 35	WOZDC0700350001	DZRPS 70 / 35	WOZDZ0700350001	4	16,5	12,5	11,5	8,2	60
70	50	DZRP 70 / 50	WOZDC0700500001	DZRPS 70 / 50	WOZDZ0700500001	4	16,5	14,5	11,5	10,0	60
95	50	DZRP 95 / 50	WOZDC0950500001	DZRPS 95 / 50	WOZDZ0950500001	4	19,0	14,5	13,5	10,0	75
95	70	DZRP 95 / 70	WOZDC0950700001	DZRPS 95 / 70	WOZDZ0950700001	4	19,0	16,5	13,5	11,5	75
120	35	DZRP 120 / 35	WOZDC1200350001	DZRPS 120 / 35	WOZDZ1200350001	4	21,0	12,5	15,5	8,2	75
120	50	DZRP 120 / 50	WOZDC1200500001	DZRPS 120 / 50	WOZDZ1200500001	4	21,0	14,5	15,5	10,0	75
120	70	DZRP 120 / 70	WOZDC1200700001	DZRPS 120 / 70	WOZDZ1200700001	4	21,0	16,5	15,5	11,5	75
120	95	DZRP 120 / 95	WOZDC1200950001	DZRPS 120 / 95	WOZDZ1200950001	4	21,0	19,0	15,5	13,5	75
150	50	DZRP 150 / 50	WOZDC1500500001	DZRPS 150 / 50	WOZDZ1500500001	4	23,5	14,5	17,0	10,0	85
150	70	DZRP 150 / 70	WOZDC1500700001	DZRPS 150 / 70	WOZDZ1500700001	4	23,5	16,5	17,0	11,5	85
150	95	DZRP 150 / 95	WOZDC1500950001	DZRPS 150 / 95	WOZDZ1500950001	4	23,5	19,0	17,0	13,5	85
150	120	DZRP 150 / 120	WOZDC1501200001	DZRPS 150 / 120	WOZDZ1501200001	4	23,5	21,0	17,0	15,5	85
185	50	DZRP 185 / 50	WOZDC1850500001	DZRPS 185 / 50	WOZDZ1850500001	4	25,5	14,5	19,0	10,0	90
185	70	DZRP 185 / 70	WOZDC1850700001	DZRPS 185 / 70	WOZDZ1850700001	4	25,5	16,5	19,0	11,5	90
185	95	DZRP 185 / 95	WOZDC1850950001	DZRPS 185 / 95	WOZDZ1850950001	4	25,5	19,0	19,0	13,5	90
185	120	DZRP 185 / 120	WOZDC1851200001	DZRPS 185 / 120	WOZDZ1851200001	4	25,5	21,0	19,0	15,5	90
185	150	DZRP 185 / 150	WOZDC1851500001	DZRPS 185 / 150	WOZDZ1851500001	4	25,5	23,5	19,0	17,0	90
240	70	DZRP 240 / 70	WOZDC2400700001	DZRPS 240 / 70	WOZDZ2400700001	4	29,0	16,5	21,5	11,5	100
240	95	DZRP 240 / 95	WOZDC2400950001	DZRPS 240 / 95	WOZDZ2400950001	4	29,0	19,0	21,5	13,5	100
240	120	DZRP 240 / 120	WOZDC2401200001	DZRPS 240 / 120	WOZDZ2401200001	4	29,0	21,0	21,5	15,5	100
240	150	DZRP 240 / 150	WOZDC2401500001	DZRPS 240 / 150	WOZDZ2401500001	4	29,0	23,5	21,5	17,0	100
240	185	DZRP 240 / 185	WOZDC2401850001	DZRPS 240 / 185	WOZDZ2401850001	4	29,0	25,5	21,5	19,0	100

DZRP, DZRPS ferrules are available on request.

Copper cable ferrules for MV cables of 10 ÷ 30kV, acc. to DIN standard - type DZO, DZOS

ON REQUEST

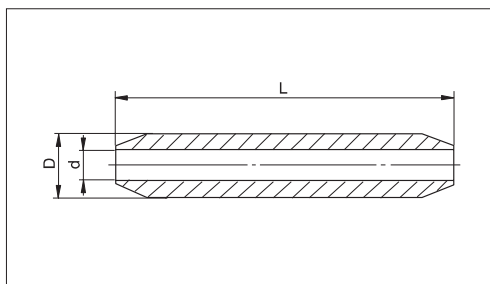

DZO - acc. to DIN standard, without galvanic coating
DZOS - acc. to DIN standard, tinned

Application	For the termination of round copper cores and sector - shaped conductors, voltage up to 10÷30kV. They increase the safety and life of connection.
Assembling	In order to make the durable assembling of ferrule, it should be pressed by using the suitable press (in case of sector cores - the core should be first formed round).
Technical data	Diameters according to DIN 46267 part 1. Material: copper pipes and bars of Cu-ETP grade according to EN 13600, PN-EN 13601. DZOS ferrules have a protective galvanized tin.

Core cross section [mm ²]	Type of ferrules	Index	Type of ferrules	Index	Packing [pcs.]	Dimensions [mm]		
						D	d	L
16	DZO 16	WOZIC0160000001	DZOS 16	WOZIZ0160000001	4	8,5	5,5	60
25	DZO 25	WOZIC0250000001	DZOS 25	WOZIZ0250000001	4	10,0	7,0	60
35	DZO 35	WOZIC0350000001	DZOS 35	WOZIZ0350000001	4	12,5	8,2	60
50	DZO 50	WOZIC0500000001	DZOS 50	WOZIZ0500000001	4	14,5	10,0	65
70	DZO 70	WOZIC0700000001	DZOS 70	WOZIZ0700000001	4	16,5	11,5	65
95	DZO 95	WOZIC0950000001	DZOS 95	WOZIZ0950000001	4	19,0	13,5	90
120	DZO 120	WOZIC1200000001	DZOS 120	WOZIZ1200000001	4	21,0	15,5	90
150	DZO 150	WOZIC1500000001	DZOS 150	WOZIZ1500000001	4	23,5	17,0	105
185	DZO 185	WOZIC1850000001	DZOS 185	WOZIZ1850000001	4	25,5	19,0	105
240	DZO 240	WOZIC2400000001	DZOS 240	WOZIZ2400000001	4	29,0	21,5	110
300	DZO 300	WOZIC3000000001	DZOS 300	WOZIZ3000000001	4	32,0	24,5	120
400	DZO 400	WOZIC4000000001	DZOS 400	WOZIZ4000000001	4	38,5	27,5	160
500	DZO 500	WOZIC5000000001	DZOS 500	WOZIZ5000000001	4	42,0	31,0	160
625	DZO 625	WOZIC6250000001	DZOS 625	WOZIZ6250000001	4	44,0	34,5	180

DZO, DZOS ferrules are available on request.

Copper ferrules for mining cables - type ZG, ZGS

ON REQUEST

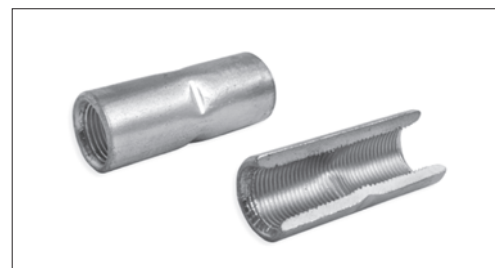
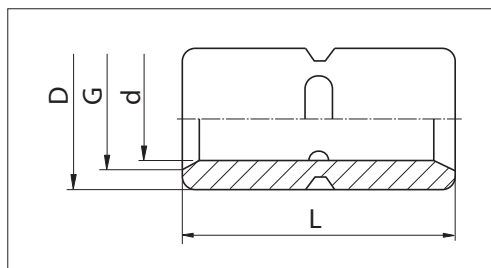

ZG - without galvanic coating
ZGS - Tinned

- Application** Ferrules on all length have thread which increase the quality and durability of the connection. They increase the safety and life of connection.
- Assembling** In order to make the durable assembling of ferrule, it should be pressed by using the suitable press.
- Technical data** Made in accordance with PN-92 / E-90146.
Material: copper pipes and bars of Cu-ETP grade according to EN 13600, PN-EN 13601.
Ferrules on all length have thread which increase the quality and durability of the connection
ZGS connectors have electroplated protective tin coatings.

Core cross section [mm ²]	Type of ferrules	Index	Type of ferrules	Index	Packing [pcs.]	Multipack [set]	Dimensions [mm]			
							D	d	G	L
16	ZG 16	WOZUC0160000001	ZGS 16	WOZUZ0160000001	4	48	11	7	M8 x 1	32
25	ZG 25	WOZUC0250000001	ZGS 25	WOZUZ0250000001	4	48	12	8	M9 x 1	40
35	ZG 35	WOZUC0350000001	ZGS 35	WOZUZ0350000001	4	48	14	10	M12 x 1	40
50	ZG 50	WOZUC0500000001	ZGS 50	WOZUZ0500000001	4	20	16	11	M12 x 1	40
70	ZG 70	WOZUC0700000001	ZGS 70	WOZUZ0700000001	4	20	18	13	M14 x 1	40
95	ZG 95	WOZUC0950000001	ZGS 95	WOZUZ0950000001	4	20	20	15	M16 x 1	40
120	ZG 120	WOZUC1200000001	ZGS 120	WOZUZ1200000001	4	12	22	17	M18 x 1	44

ZG, ZGS ferrules are available on request.

Tinned ferrules with hole - type ZCS

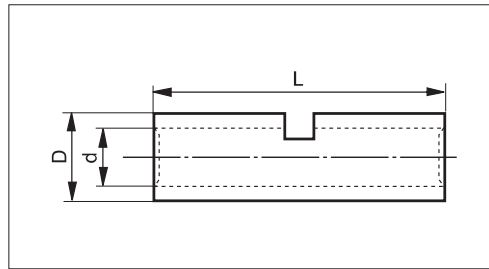

Application For connection of alarm system wires at heating pipes.
They increase the safety and life of connection.

Assembling In order to make the durable assembling of ferrule, it should be pressed by using the suitable press.

Technical data Material: copper pipes.
They have a tin-coated protective coating.

Core cross section [mm ²]	Type of ferrules	Index	Packing [pcs.]	Dimensions [mm]		
				D	d	L
2,5 ÷ 4	ZCS 4	TOZAZ0040000002	100	4,7	3,0	20

Butt connectors insulated - type ZKI

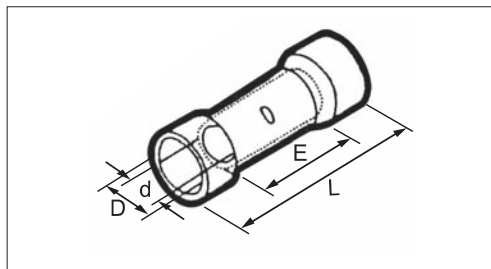

Application	To connect copper wires. They increase safety, durability of connection and protect against electric shock when touching. Intended for installation in dry areas.
Assembling	In order to make the durable assembling of ferrule, it should be pressed by using the suitable press.
Technical data	Copper tubes, tinned-plated, PVC isolation.

Core cross section [mm ²] input	Type of ferrules	Index	Packing [pcs.]	Dimensions [mm]				Insulation colour
				D	d	L	E	
0,5 ÷ 1,5	ZKI 1,5	TOZAI0010000001	100	4,0	1,9	23,7	15	red
1,5 ÷ 2,5	ZKI 2,5	TOZAI0020000001	100	4,5	2,4	23,7	15	blue
4 ÷ 6	ZKI 6	TOZAI0060000001	100	6,8	4,0	25,7	15	yellow

Copper butt connectors with shrinkable insulation with adhesive - type ZKIT

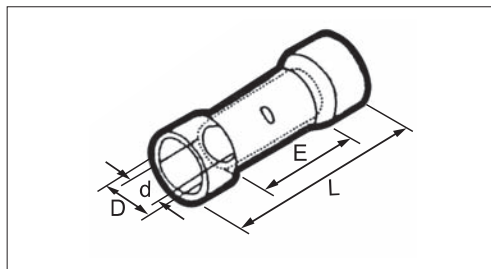

Application For connecting copper conductors exposed to moisture, popular home applications, e.g. doorbell, alarm systems.
They increase safety and durability of the connection and assure proper insulation.

Assembling To mount the connector permanently, it is necessary to press it by means of the press with jaws intended for connectors with heat-shrink insulation (with non-sharp edges). The press must have a proper pressure force so that there is a minimum space which is supposed to secure the connector insulation against damage at the last stage. After pressing, shrink the insulation of connectors by means of the heater or a soft flame.

Technical data Galvanic copper pipes, heat-shrink insulation with glue.

Core cross section [mm ²] input	Type of ferrules	Index	Packing [pcs.]	Cumulative packing [pcs.]	Dimensions [mm]				Insulation colour
					D	d	L	E	
0,5 ÷ 1,5	ZKIT 1,5	TOZAK0010000001	100	50	4,5	1,7	35,0	15	red
1,5 ÷ 2,5	ZKIT 2,5	TOZAK0020000001	100	50	5,5	2,3	37,0	15	blue
4 ÷ 6	ZKIT 6	TOZAK0060000001	100	50	6,5	3,4	41,0	15	yellow

Copper cable ferrule with tin and heat-shrinkable insulation with adhesive - type ZKIC

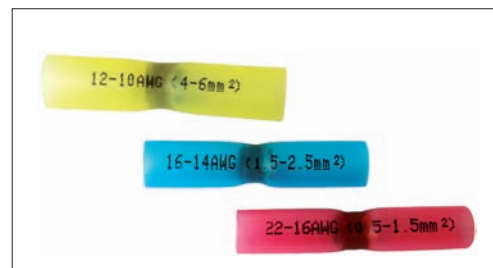
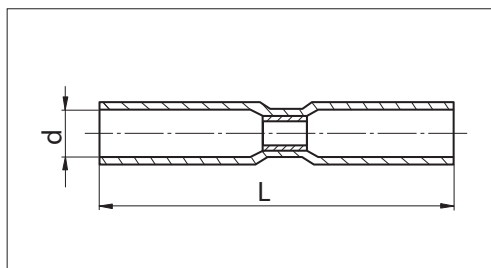
**Application**

For connecting copper conductors exposed to moisture, popular home application, e.g. doorbell or alarm systems.

The increase safety and durability of the connection, assure proper insulation and fast assembly without the use of a press.

Assembling

After isolating ends of conductors at the length of about 10mm, it is necessary to place them in parallel next to one another inside the central part with tin which solders them after heating.

Next, shrink it by means of the heater or soft flame, at the beginning heat the central part carefully and move to ends of the connector.

Technical data

Soldering tin, heat-shrink insulation with glue.

Working temperature: $-30 \div 105^{\circ}\text{C}$.

Rated voltage 600 V.

Core cross section [mm ²]	Type of ferrules	Index	Packing [pcs.]	Dimensions [mm]		Insulation colour
				d	L	
0,2 ÷ 0,5	ZKIC 0,5	TOZAM0000000051	100	2,5	25	colorless
0,5 ÷ 1,5	ZKIC 1,5	TOZAM0000000151	100	4,2	37	red
1,5 ÷ 2,5	ZKIC 2,5	TOZAM0000000251	100	4,7	37	blue
4 ÷ 6	ZKIC 6	TOZAM0000000602	100	6,0	42	yellow

Aluminum-copper cable terminals, for voltages up to 30 kV, leakproof, acc. to DIN standard - type DKAMP

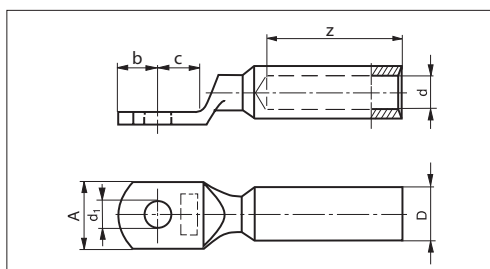

Application

Aluminum-copper cable terminals are used for termination of aluminum conductors (round and sector-shaped conductors) for the purpose to connect them to copper bars. They increase the safety and life of connection thanks to the elimination of disadvantageous contact of aluminum with copper, using the friction method in the both metals connection.

Assembling

In order to make the durable assembling of terminal, it should be pressed by using the suitable press (in case of sector cores - the core should be first formed round).

Technical data

Accordanace with DIN 46 329 standard concerns only the tubular parts of the terminals. Cable terminals are made of aluminum bars in the recrystallizing condition of EN AW-1050 A grade PN-EN 573-3 and of copper bars in grade Cu-ETP acc. with PN-EN 13601. Special contact paste applied inside terminals acc. to DIN standards improve the quality of the connection. For the assurance of suitable plasticity of contact paste, the terminals are packed separately one piece in one folie sack.

Core cross sect. [mm ²]		Type of terminals	Index	Packing [pcs.]	Cumulative packing [pcs.]	Dimensions [mm]						
rm, sm	se					D	d	d ₁	A	b	c	z
16	25	DKAMP 16/6.	WOKDD0160000601	4	48	12	5,6	6,5	13	8,5	8	30
25	35	DKAMP 25/8.	WOKDD0250000801	4	48	12	6,8	8,5	16	11	10	30
35	50	DKAMP 35/10.	WOKDD0350001001	4	48	14	8	10,5	19	13	12	42
35	50	DKAMP 35/12	WOKDD0350001201	4	48	14	8	13	21	14	13	42
50	70	DKAMP 50/10.	WOKDD0500001001	4	20	16	9,8	10,5	22	13	12	42
50	70	DKAMP 50/12	WOKDD0500001201	4	20	16	9,8	13	24	14	13	42
70	95	DKAMP 70/10	WOKDD0700001001	4	20	18,5	11,2	10,5	24	13	12	52
70	95	DKAMP 70/12.	WOKDD0700001201	4	20	18,5	11,2	13	24	14	13	52
70	95	DKAMP 70/16	WOKDD0700001601	4	20	18,5	11,2	17	30	17	16	52
95	120	DKAMP 95/10	WOKDD0950001001	4	20	22	13,2	10,5	28	13	12	56
95	120	DKAMP 95/12.	WOKDD0950001201	4	20	22	13,2	13	28	14	13	56
120	150	DKAMP 120/12.	WOKDD1200001201	4	12	23	14,7	13	32	14	13	56
120	150	DKAMP 120/16	WOKDD1500001601	4	12	23	14,7	17	32	17	16	56
150	185	DKAMP 150/12	WOKDD1500001201	4	12	25	16,3	13	34	14	13	60
150	185	DKAMP 150/16.	WOKDD1500001601	4	12	25	16,3	17	34	17	16	60
185	240	DKAMP 185/12	WOKDD1850001201	4	12	28,5	18,3	13	37	14	13	60
185	240	DKAMP 185/16.	WOKDD1850001601	4	12	28,5	18,3	17	37	17	16	60
240	300	DKAMP 240/12	WOKDD2400001201	4	12	32	21	13	42	14	13	70
240	300	DKAMP 240/16.	WOKDD2400001601	4	12	32	21	17	42	17	16	70
300	-	DKAMP 300/16.	WOKDD3000001601	4	12	34	23,3	17	48	17	16	70

rm - round bunched core, sm - segmental bunched core, se - segmental solid core.

Aluminum-copper cable ferrules with leakproof partition, acc. to DIN standard - type DZAM

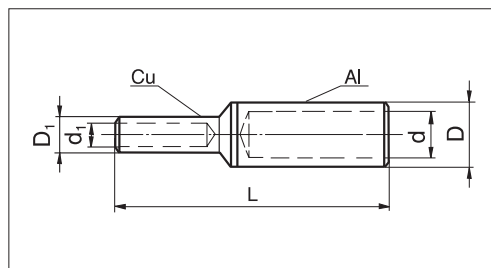
Application

Aluminum-copper cable ferrules are used for connection of aluminum and copper conductor. The aluminum and copper connection is obtained using of friction method, and it causes the elimination of disadvantageous effects on the aluminum with copper contact.

Assembling

In order to make the durable assembling of ferrule, it should be pressed by using the suitable press (in case of sector cores - the core should be first formed round).

Technical data

Accordanace with DIN 46 267 standard concerns only the tubular parts of the ferrules. Cable ferrules are made of aluminum bars in the recrystallizing condition of EN AW-1050 A grade PN-EN 573-3 and of copper bars in grade Cu-ETP acc. with PN-EN 13601. Special contact paste applied inside ferrules acc. to DIN standards improve the quality of the connection. For the assurance of suitable plasticity of contact paste, the ferrules are packed separately one piece in one folie sack.

Core cross section [mm ²]			Type of ferrules	Index	Packing [pcs.]	Dimensions [mm]				
Al rm, sm	se	Cu rm, se				D	d	D ₁	d ₁	L
16	25	10	DZAM 16 / 10	WOZDD0160100001	4	12,0	5,6	6,0	4,5	57,0
16	25	16	DZAM 16 / 16	WOZDD0160160001	4	12,0	5,6	8,5	5,5	61,0
25	35	10	DZAM 25 / 10	WOZDD0250100001	4	12,0	6,8	6,0	4,5	55,0
25	35	16	DZAM 25 / 16	WOZDD0250160001	4	12,0	6,8	8,5	5,5	61,0
25	35	25	DZAM 25 / 25	WOZDD0250250001	4	12,0	6,8	10,0	7,0	61,0
35	50	16	DZAM 35 / 16	WOZDD0350160001	4	14,0	8,0	8,5	5,5	71,0
35	50	25	DZAM 35 / 25	WOZDD0350250001	4	14,0	8,0	10,0	7,0	71,0
35	50	35	DZAM 35 / 35	WOZDD0350350001	4	14,0	8,0	12,5	8,2	71,0
50	70	25	DZAM 50 / 25	WOZDD0500250001	4	16,0	9,8	10,0	7,0	71,5
50	70	35	DZAM 50 / 35	WOZDD0500350001	4	16,0	9,8	12,5	8,2	71,5
50	70	50	DZAM 50 / 50	WOZDD0500500001	4	16,0	9,8	14,5	10,0	77,5
70	95	25	DZAM 70 / 25	WOZDD0700250001	4	18,5	11,2	10,0	7,0	79,0
70	95	35	DZAM 70 / 35	WOZDD0700350001	4	18,5	11,2	12,5	8,2	79,0
70	95	50	DZAM 70 / 50	WOZDD0700500001	4	18,5	11,2	14,5	10,0	85,0
70	95	70	DZAM 70 / 70	WOZDD0700700001	4	18,5	11,2	16,5	11,5	86,0
95	120	50	DZAM 95 / 50	WOZDD0950500001	4	22,0	13,2	14,5	10,0	85,0
95	120	70	DZAM 95 / 70	WOZDD0950700001	4	22,0	13,2	16,5	11,5	87,0
95	120	95	DZAM 95 / 95	WOZDD0950950001	4	22,0	13,2	19,0	13,5	95,0
120	150	35	DZAM 120 / 35	WOZDD1200350001	4	23,0	14,7	12,5	8,2	81,0
120	150	50	DZAM 120 / 50	WOZDD1200500001	4	23,0	14,7	14,5	10,0	87,0
120	150	70	DZAM 120 / 70	WOZDD1200700001	4	23,0	14,7	16,5	11,5	89,0
120	150	95	DZAM 120 / 95	WOZDD1200950001	4	23,0	14,7	19,0	13,5	97,0
120	150	120	DZAM 120 / 120	WOZDD1201200001	4	23,0	14,7	21,0	15,5	97,0
150	185	70	DZAM 150 / 70	WOZDD1500700001	4	25,0	16,3	16,5	11,5	99,5
150	185	95	DZAM 150 / 95	WOZDD1500950001	4	25,0	16,3	19,0	13,5	107,5
150	185	120	DZAM 150 / 120	WOZDD1501200001	4	25,0	16,3	21,0	15,5	107,5
150	185	150	DZAM 150 / 150	WOZDD1501500001	4	25,0	16,3	23,5	17,0	107,5
185	240	120	DZAM 185 / 120	WOZDD1851200001	4	28,5	18,3	21,0	15,5	108,0
185	240	150	DZAM 185 / 150	WOZDD1851500001	4	28,5	18,3	23,5	17,0	113,0
185	240	185	DZAM 185 / 185	WOZDD1851850001	4	28,5	18,3	25,5	19,0	116,0
240	300	50	DZAM 240 / 50	WOZDD2400500001	4	32,0	21,0	14,5	10,0	110,0
240	300	70	DZAM 240 / 70	WOZDD2400700001	4	32,0	21,0	16,5	11,5	111,0
240	300	95	DZAM 240 / 95	WOZDD2400950001	4	32,0	21,0	19,0	13,5	119,0
240	300	120	DZAM 240 / 120	WOZDD2401200001	4	32,0	21,0	21,0	15,5	119,0
240	300	150	DZAM 240 / 150	WOZDD2401500001	4	32,0	21,0	23,5	17,0	124,0
240	300	185	DZAM 240 / 185	WOZDD2401850001	4	32,0	21,0	25,5	19,0	127,0
240	300	240	DZAM 240 / 240	WOZDD2402400001	4	32,0	21,0	29,0	21,5	128,0

rm - round bunched core, sm - segmental bunched core, se - segmental solid core.

DZAM ferrules are available on request.

Aluminum-copper pins with leakproof partition, acc. to DIN standard - type DBAM

ON REQUEST

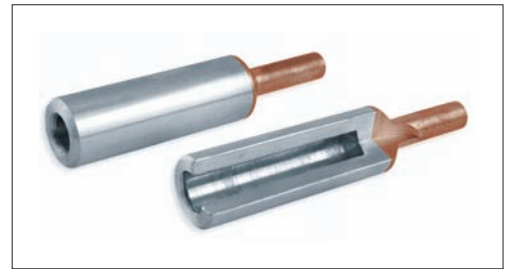
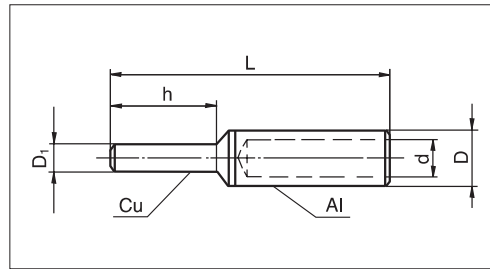
**Application**

Aluminum-copper pins are used for termination of aluminum cores (round and sector shaped conductors) connected to the receiving devices with the use of the current clips. They increase the safety, quality and life of the connection thanks to elimination of the chemical reaction occurring in contact of two different metals.

Assembling

In order to make the durable assembling of the cable pin, it should be pressed by using the suitable press (in case of sector cores - the core should be first formed round).

Technical data

Dimensions of the pipe part according to DIN 46267 Part 2, except for the 16 mm² section, which is not covered by the standard.

Material: aluminum bars in the recrystallizing condition of EN AW-1050 A grade according to PN-EN 573-3 and of copper bars in grade Cu-ETP acc. with EN 13600 PN-EN 13601.

Special contact paste applied inside pins acc. improve the quality of the connection.

For the assurance of suitable plasticity of contact paste, the pins are packed separately one piece in one folie sack.

Core cross section [mm ²]		Type of pins	Index	Packing [pcs.]	Dimensions [mm]				
mm	sm				D	D ₁	d	h	L
16	25	DBAM 16	WOKTD0160000001	4	12,0	5	5,6	18	56
25	35	DBAM 25	WOKTD0250000001	4	12,0	6	6,8	20	58
35	50	DBAM 35	WOKTD0350000001	4	14,0	7	8,0	22	71
50	70	DBAM 50	WOKTD0500000001	4	16,0	8	9,8	25	74
70	95	DBAM 70	WOKTD0700000001	4	18,5	10	11,2	30	87
95	120	DBAM 95	WOKTD0950000001	4	22,0	12	13,2	33	91
120	150	DBAM 120	WOKTD1200000001	4	23,0	12	14,7	38	97
150	185	DBAM 150	WOKTD1500000001	4	25,0	12	16,3	38	108
185	240	DBAM 185	WOKTD1850000001	4	28,5	14	18,3	44	116
240	300	DBAM 240	WOKTD2400000001	4	32,0	16	21,0	44	128

DBAM pins are available on request.

Aluminum-copper washers - type PC

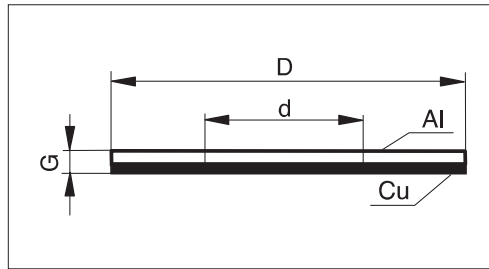
**Application**

Al-Cu washers eliminate a micellating effect on the contact of two different metals.

The washers applied to electrical circuits cause reduction of energy loss.

They increase the safety and the life of connection. Except the application in power engineering, the washers can be used in electrical installations for the connection of parts made of aluminum and copper.

Technical data

Washers are made of AL/CU sheet.

Type of washers	Index	Packing [pcs.]	Cumulative packing [pcs.]	Dimensions [mm]		
				D	d	g
PC 3,5	WOPAD08503501	100	80	8,5	3,5	1
PC 5,5	WOPAD01105501	100	50	11	5,5	1
PC 6,5	WOPAD01306501	100	45	13	6,5	1
PC 8,5	WOPAD01908501	100	35	19	8,5	1
PC 11,0	WOPAD02401101	100	25	24	11,0	1
PC 13,0	WOPAD03001301	100	25	30	13,0	1
PC 17,0	WOPAD03801701	100	20	38	17,0	1
PC 21,0	WOPAD03802101	100	15	38	21,0	1

Screw-like cable ends, tight, for voltage up to 36kV – SN ML36 type

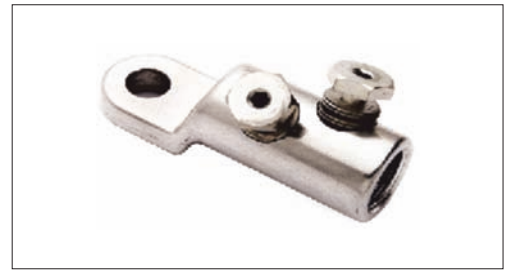
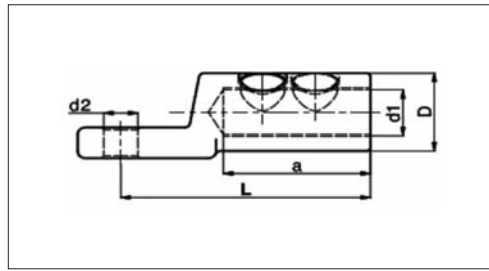

Application	They are intended for finishing the cables with aluminum and copper conductors (round and sector) for voltage up to 36kV. They increase safety and durability and quality of connection thanks to lock bolts after the proper pressure force has been reached.
Assembling	After placing the cable conductor in the end, it is necessary to screw the bolt in until breaking.
Technical data	Body made of high-resistance aluminum alloy, tinplated; brass bolts, tinplated. The ends are packed in separate packaging which contains assembly manual and rings intended for positioning cable conductors. Compliance with standard IEC 61238-1 class A.

Type	Cross section AL [mm ²]				Cu [mm ²]		Dimensions [mm]					Screws
	rm	re	sm	se	rm	sm	d2	d1	D	a	L	
SN ML36-16-95x12	16-70	16-95	25-70	16-95	16-70	25-70	13,0	12,5	24,0	32,0	60	1
SN ML36-50-150x12	50-120	50-150	50-120	50-150	50-120	50-120	13,0	15,0	30,0	35,0	79	1
SN ML36-95-240x12	95-185	95-240	95-185	95-240	95-185	95-185	13,0	20,0	33,0	56,0	95	2

Screw-like cable connectors, tight, for voltage up to 36 kV - SN MC36 type

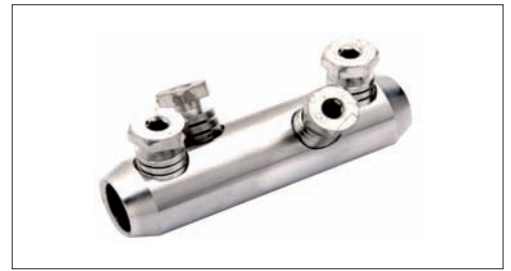
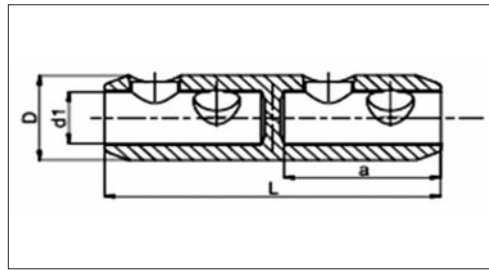

Application	They serve to connect cables with aluminum and copper conductors (round and sector) for voltage up to 36kV. They increase safety, durability and quality of connection thanks to lock bolts after the proper pressure force has been reached.
Assembling	After the cable conductor has been placed in the connector, it is necessary to screw the bolt in until breaking.
Technical data	The body made of high-resistance aluminum alloy, tinned; brass bolts, tinned. Connectors are packed in separate packaging which contains assembly manual and rings for positioning the cable conductor. Compliance with standard IEC 61238-1 class A.

Type	Cross section AL [mm ²]					Cu [mm ²]		d1	Dimensions [mm]			Screws
	rm	re	sm	se	rmv	rm	sm		D	a	L	
SN MC36-16-95	16-95	10-95	25-70	10-95	16-95	10-70	25-70	12,5	24,0	32	70	2
SN MC36-50-150	50-150	50-150	50-120	50-150	50-150	35-120	50-120	15,5	30,0	35	85	2
SN MC36-95-240	95-240	95-240	120-185	95-240	95-240	95-240	95-185	20,0	33,0	56	120	4

12-way thread terminal blocks for wires - type Z12T

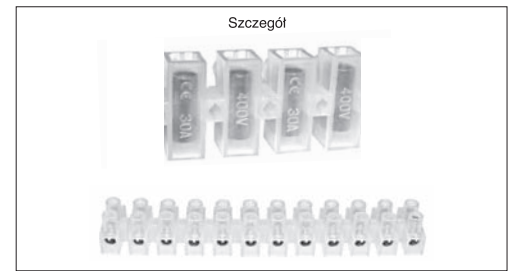
**Application**

12-way thread terminal blocks for wires are used for wires connection in electro-installation boxes, lighting technics, switchgear boxes and other electro-installation works. The guarantee easy separation of current ways. Blocks can be easily divided with the use of installation knife. Special holes enable fastening the blocks to the foundation.

Technical data

The body of blocks is made of polyethylene PE.
Grips are made of brass with steel tinned screws.
Working temperature: from - 40°C to + 80°C.

Core cross section [mm ²]	Type of terminal	Index	Packing [pcs.]	Rated current [A]	Length [mm]	Colour
0,5 ÷ 2,5	Z12T 2,5	TOLA02	10	3 ÷ 24	93	orange
2,5 ÷ 4	Z12T 4	TOLA04	10	5 ÷ 32	114	orange
4 ÷ 6	Z12T 6	TOLA06	10	10 ÷ 57	125	orange
10	Z12T 10	TOLA10	10	15 ÷ 61	138	orange
16	Z12T 16	TOLA16	10	30 ÷ 76	165	orange
0,5 ÷ 2,5	Z12T 2,5-BB	TOLA02B	10	3 ÷ 24	93	colorless
2,5 ÷ 4	Z12T 4-BB	TOLA04B	10	5 ÷ 32	114	colorless
4 ÷ 6	Z12T 6-BB	TOLA06B	10	10 ÷ 57	125	colorless
10	Z12T 10-BB	TOLA0110B	10	15 ÷ 61	138	colorless
16	Z12T 16-BB	TOLA016B	10	30 ÷ 76	165	colorless

Installation connectors, quick couplings – SDK type

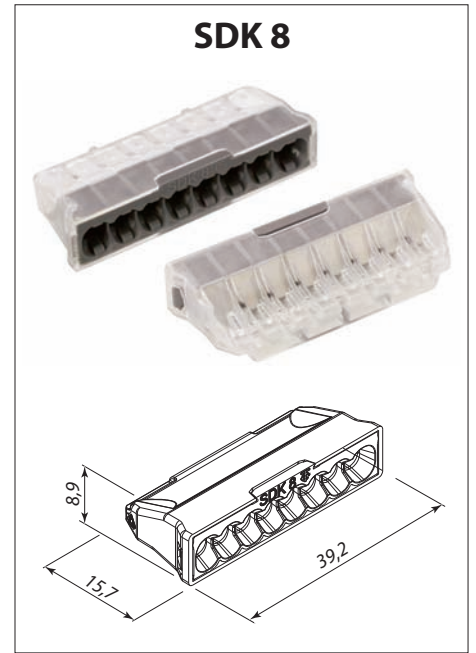
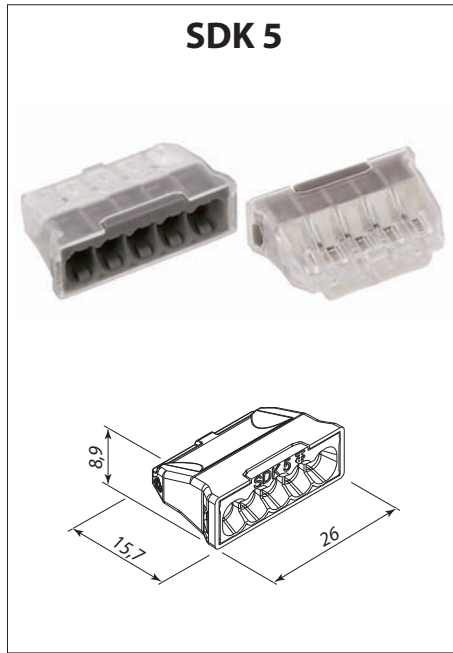
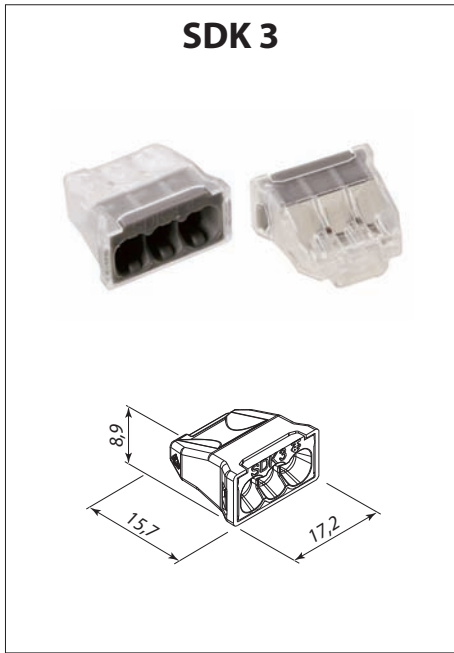

Application

For quick connecting single- and multi- conductors in the range 0,5-2,5 mm². Transparent casing allows inspecting the proper connection..

Assembling

After isolating the conductor at the length of 8 - 9 mm, it is necessary to insert it in the connector hole.

Technical data

Clamp cover made of polycarbonate, casing made of polyamide, copper insert, compression spring made of stainless steel.
 Rated voltage: Europe 450V, USA 600V. Rated current: Europe 24A, USA 20A.
 Wire section: 0,5 - 2,5 mm² single conductors and 1,5 - 2,5 mm² multi conductors.
 Maximum ambient temperature: Europe 90°C, USA 105°C.

Product name	Index	Number of mounting holes	Packing [pcs.]	Length [mm]
SDK 3	TOZAC0020000045	3	100	8,5
SDK 5	TOZAC0020000046	5	100	11
SDK 8	TOZAC0020000047	8	50	13

Possible connect various types of conductors of other sections



Insulation removal 8 - 9 mm



Releasing the wire through rotation and removal



Typical application of SDK 3 in junction box



Testing connection by means of the probe whose diameter is 2 mm in the external junction box

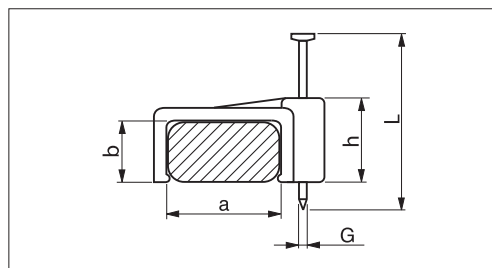

For flat conductors fastening - type FP

**Application**

The fasteners are supposed to fast fastening of conductors. The hardened nail makes easy the assembling to different foundations, and the using of KR1 stretched pins causes better security of the fastening. Special shape of fasteners for round and flat conductors, increases the security of the assembling. Comfortable application for aesthetic and cheap installation.

Assembling

Flop fasteners can be fastened driving nails directly to the foundation or to the put in KR1 stretched pin.

Technical data

Still hardened tinned nail. The fasteners and stretched pins are made of polypropylene (BN-79/6364-03). Operating temperature from -15°C up to +70°C.

Fasteners are packed in foil or blisters. For shops and warehouses we recommend comfortable kit - stand with fasteners' set of most popular dimensions packed in blisters.

Packed in sack

Product name	Index	Packing [pcs.]	Cumulative packing [sets]	Dimensions [mm]				
				a	b	h	L	G
FP 5 / 3	TOUFP0501	100	40	5	3,5	5,5	20	1,8
FP 6 / 4	TOUFP0601	100	40	6	4,0	6,0	22	1,8
FP 8 / 5	TOUFP0801	100	20	8	5,0	7,0	27	2,0
FP 10 / 6	TOUFP1001	100	20	10	5,5	8,0	26	2,3
FP 12 / 6	TOUFP1201	100	15	12	6,0	9,5	26	2,0

Packed in blisters

Product name	Index	Packing [pcs.]	Cumulative packing [sets]	Dimensions [mm]				
				a	b	h	L	G
BFP 5 / 3	WOUFP0011	50	10	5	3,5	5,5	20	1,8
BFP 6 / 4	WOUFP0021	60	10	6	4,0	6,0	22	1,8
BFP 8 / 5	WOUFP0031	40	10	8	5,0	7,0	27	2,0
BFP 10 / 6	WOUFP0041	80	10	10	5,5	8,0	26	2,3
BFP 12 / 6	WOUFP0051	60	10	12	6,0	9,5	26	2,0

Product name	Conductor type
FP 5 / 3	SMYp 2x0,75; SMYp 2x0,5; TKSy 1x2x0,5; OMYp 2x0,5
FP 6 / 4	OMYp 2x0,75; OMYp 2x1
FP 8 / 5	OMYp 2x1,5; YDYp 300/500V 2x1; 2x1,5; 2x2,5
FP 10 / 6	YDYp 450/750V 2x1 i 2x1,5; YDYp 300/500V 3x1 i 3x1,5
FP 12 / 6	YDYp 450/750V 3x1 i 3x1,5; YDYp 300/500V 3x2,5

For round conductors fastening - type FO

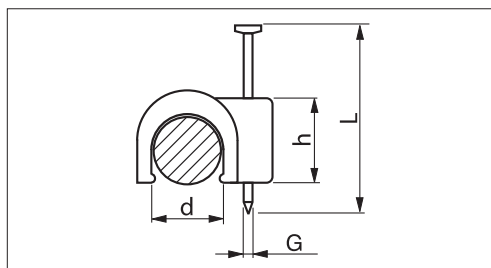
**Application**

The fasteners are supposed to fast fastening of conductors. The hardened nail makes easy the assembling to different foundations, and the using of KR1 stretched pins causes better security of the fastening. Special shape of fasteners for round and flat conductors, increases the security of the assembling. Comfortable application for aesthetic and cheap installation.

Assembling

Flop fasteners can be fastened driving nails directly to the foundation or to the put in KR1 stretched pin.

Technical data

Still hardened tinned nail. The fasteners and stretched pins are made of polypropylene (BN-79/6364-03). Operating temperature from -15°C up to +70°C.

Fasteners are packed in foil or blisters. For shops and warehouses we recommend comfortable kit - stand with fasteners' set of most popular dimensions packed in blisters.

Packed in sack

Product name	Index	Packing [pcs.]	Cumulative packing [sets]	Dimensions [mm]			
				d	h	L	G
FO 3	TOUFO0301	100	60	3	5,0	20	1,5
FO 4	TOUFO0401	100	50	4	5,0	22	1,8
FO 5	TOUFO0501	100	40	5	5,5	22	1,8
FO 6	TOUFO0601	100	30	6	7,5	25	1,8
FO 7	TOUFO0701	100	25	7	7,5	25	1,8
FO 8	TOUFO0801	100	20	8	9,0	27	2,0
FO 9	TOUFO0901	100	15	9	10,0	27	2,0
FO 10	TOUFO1001	100	15	10	11,0	27	2,0
FO 12	TOUFO1201	100	12	12	13,0	28	2,2
FO 16	TOUFO1601	100	6	16	16,5	38	2,4

Packed in blisters

Product name	Index	Packing [pcs.]	Cumulative packing [sets]	Dimensions [mm]			
				a	b	h	L
BFO 3	WOUFO0011	60	10	3	5,0	20	2,0
BFO 4	WOUFO0021	60	10	4	5,0	22	1,8
BFO 5	WOUFO0031	50	10	5	5,5	22	1,8
BFO 6	WOUFO0041	70	10	6	7,5	25	1,8
BFO 7	WOUFO0051	70	10	7	7,5	25	1,8
BFO 8	WOUFO0061	60	10	8	9,0	27	2,0
BFO 9	WOUFO0071	40	10	9	10,0	27	2,0
BFO 10	WOUFO0081	50	10	10	11,0	27	2,0
BFO 12	WOUFO0091	50	10	12	13,0	28	2,2

Product name	Conductor type	Product name	Conductor type
FO 3	LgY 1x2,5; YTDY 4x0,5	FO 8	YDY 2x1,5; YDY 3x1
FO 4	LgY 1x4	FO 9	YDY 3x1,5; YDY 4x1; YFY 4x1,5; OWY 4x1,5
FO 5	OMY 2x1; 2x1,5; 3x0,5; LgY 1x6	FO 10	YDY 2x4; YDY 3x4; LgY 1x35
FO 6	LgY 1x10; OMY 2x1,5; WDX 75-1; YTDY 16x0,5	FO 12	LgY 1x50
FO 7	YDY 2x1; LgY 1x16	FO 16	OWY 5x4; LgY 1x95; YDY 4x6

Pull apart pins - type KR1

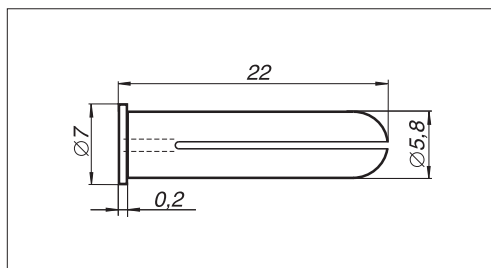
**Application**

Meant for fastening of grips with pin in places where assembling only with the use of pin is not possible or is not strong enough.

Assembling

For stable foundations e.g. firm concrete - use drill Ø6, for fragile foundations use drill O5 Ø5.

Technical data

Material: polypropylene.

Product name	Index	Packing [pcs.]	Cumulative packing [sets]
KR1	WKI006	100	60

Quick assembly holders for flat conductors - type USMP

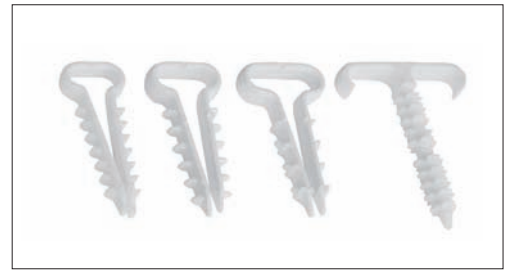

- Application** Meant for easy and quick assembly of round and flat conductors and pipes in on-wall, ceiling and floor installations. They guarantee low assembly costs and professional appearance of installation.
- Assembling** Conductor is being put in into holder which is next placed in the drilled-hole.
- Technical data** Material: polypropylene.

Name of set	Index	Max. width of conductor [mm]	Used for conductors	Assembly		Packing [pcs.]
				Drill dimension [mm]	Hole depth [mm]	
USMP 11	TOUSP01	11	YDYp 2x1; 2x1,5; 2x2,5; 3x1; 3x1,5	6 ÷ 6,5	35	100
USMP 13	TOUSP02	13	YDYp 3x1,5; 3x2,5; UTP-dual	6 ÷ 6,5	35	100
USMP 16	TOUSP03	16	YDYp 4x1,5; 4x2,5	6 ÷ 6,5	35	100
USMP 2x13	TOUSP04	13	YDYp 3x1,5; 3x2,5; 4x1,5; UTP-dual	6 ÷ 6,5	40	50

Quick assembly holders for round conductors - type USMO

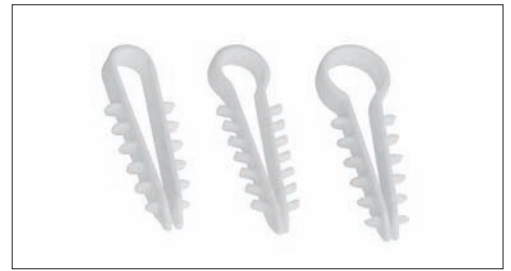

- Application** Meant for easy and quick assembly of round and flat conductors and pipes in on-wall, ceiling and floor installations. They guarantee low assembly costs and professional appearance of installation.
- Assembling** Conductor is being put in into holder which is next placed in the drilled-hole.
- Technical data** Material: polypropylene.

Name of set	Indeks	Conductor diameter		Used for conductors	Assembly		Packing [pcs.]
		from [mm]	to [mm]		Drill dimension [mm]	Hole depth [mm]	
USMO 6	TOUSO01	5	7	YTKSY 1x2x0,5; 1x4x0,5; 5x2x0,5; DY6; UYP	6 ÷ 6,5	35	100
USMO 8	TOUSO02	7	9	YDY 2x1; 2x1,5; 3x1; antenowe i tel. kablowej	6 ÷ 6,5	35	100
USMO 10	TOUSO03	9	11	YDY 2x2,5; 2x1,5; 3x1,5; 3x2,5; 4x1; 4x1,5	6 ÷ 6,5	35	100

Hook quick assembly holders for pipes - type USMH



- Application** Meant for easy and quick assembly of round and flat conductors and pipes in on-wall, ceiling and floor installations. They guarantee low assembly costs and professional appearance of installation.
- Assembling** Conductor is being put in into holder which is next placed in the drilled-hole.
- Technical data** Material: polypropylene.

Name of set	Index	Conductor diameter		Used for conductors	Assembly		Packing [pcs.]
		from[mm]	to [mm]		Drill dim. [mm]	Hole depth [mm]	
USMH 18-22	TOUSH01	18	22	Installation pipes: smooth and corrugated	7 ÷ 8	50	100
USMH 2x18-22	TOUSH02	18	22	conductors YDY 5x10; 7x6; 7x10; 10x2,5; 10x4	7 ÷ 8	50	100

Retainers with assembly eye – UMD type

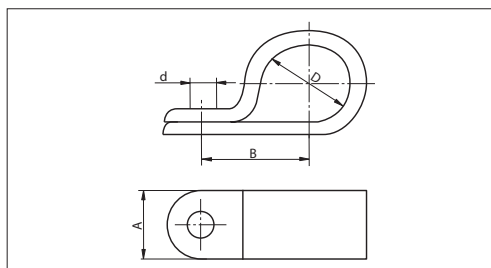
**Application**

For stable assembly of pipes and cables.
They assure low assembly costs and professional design.

Assembling

Once the grip has been put on the element, we must screw it in the surface by means of the tap screw or bolt.

Technical data

Polyamide 6.6. They do not contain halides, cadmium, mercury, lead, chromium.
Assembly temperature: from 0 to 40°C, working temperature: from -40 to 85°C.
White color.

Type of holder	Indeks	Packing [pcs.]	Dimensions [mm]			
			D	d	A	B
UMD 3,2	TOUZW0032	100	3,2	5,2	13	9
UMD 4,3	TOUZW0043	100	4,3	5,2	10,5	10,5
UMD 7,6	TOUZW0076	100	7,6	4,8	9,5	10,5
UMD 8,7	TOUZW0087	100	8,7	4,8	9,5	12,5
UMD 12,6	TOUZW0126	100	12,6	4,8	12,4	15
UMD 15,8	TOUZW0158	100	15,8	4,8	12	18
UMD 19,4	TOUZW0194	100	19,4	4,8	12	18
UMD 25,4	TOUZW0254	100	25,4	4,8	12	22

Collective cable holders - type UKZ

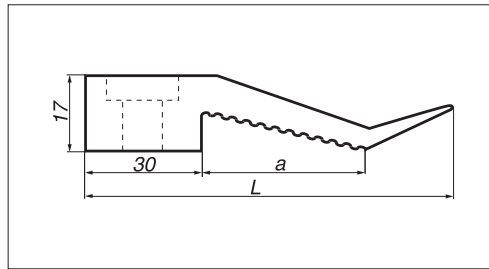
**Application**

They are meant for collective fastening of power conductors in on-wall, ceiling and floor installations. Their flexible construction and pull off holder enable easy and reliable holding of conductors. Due to flat shape they can be applied in under-plaster work installations. Low installation costs are guaranteed thanks to shortening the assembly time.

Assembling

Mounting with a screw or screw.

Technical data

Material: polypropylene.

Name of set	Index	Dimens. [mm]		Used for conductors	Assembly	Packin [pcs.]g
		a	L			
UKZ 52	TOUA02	52	105	max. 6 conductors: YDY 2x2,5; 3x1,5; 3x2,5; 4x1; 4x1,5	Max. diameters:	50
UKZ 77	TOUA03	77	130	max. 9 conductors: YDY 2x2,5; 3x1,5; 3x2,5; 4x1; 4x1,5	screw 6 mm,	50
UKZ 2x77	TOUA01	2 x 77	230	max. 2 x 9 conductors: YDY 2x2,5; 3x1,5; 3x2,5; 4x1; 4x1,5	screw head 11 mm	50

Cable hitching grips - type UP

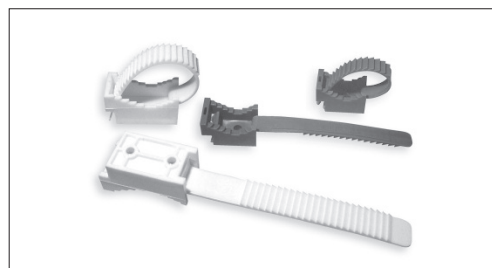
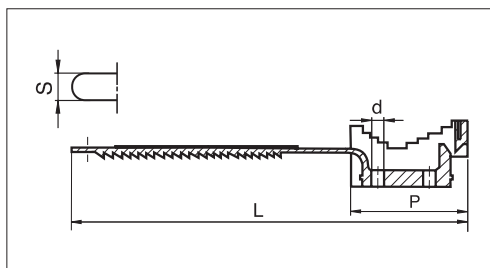

Application The hitching grips are applied for the fastening of power engineering conductors. They are very flexible. UP type ties have zip for multiple using

Assembling Screw down the grips to the foundation with the aid eg. concrete, wood, steel screws ((the grips are sold without the screws). Depending on dimensions, the grip have holes for 1 or 2 screws.

Technical data Material: polietylen (PN-86/C-89280).
Operating temperature: from -15° to 70°C.
Standard version and UV resistant version (name: UP ... UV).

Product name	Index	Max. diameter of bunch [mm]	Packing [pcs.]	Cumulative packing [sets]	L	Dimensions [mm]			Colours
						d	P	S	
UP 22-B	WOUZ001W1	18	100	20	93	4,5	28	10	white
UP 30-B	WOUZ002W1	30	100	10	145	5,4	37	13	white
UP 50-B	WOUZ003W1	45	10	30	220	2 x 6,4	61	22	white
UP 22-C	WOUZ001B1	18	100	20	93	4,5	28	10	black
UP 30-C	WOUZ002B1	30	100	10	145	5,4	37	13	black
UP 50-C	WOUZ003B1	45	10	30	220	2 x 6,4	61	22	black
UP 22 UV-B	WOUZ001WV1	18	100	20	93	4,5	28	10	white
UP 30 UV-B	WOUZ002WV1	30	100	10	145	5,4	37	13	white
UP 22 UV-C	WOUZ001BV1	18	100	20	93	4,5	28	10	white
UP 30 UV-C	WOUZ002BV1	30	100	10	145	5,4	37	13	black
UP 50 UV-C	WOUZ003BV1	45	10	30	220	2 x 6,4	61	22	black

All-purpose cable grips for cables and pipes - type UKU

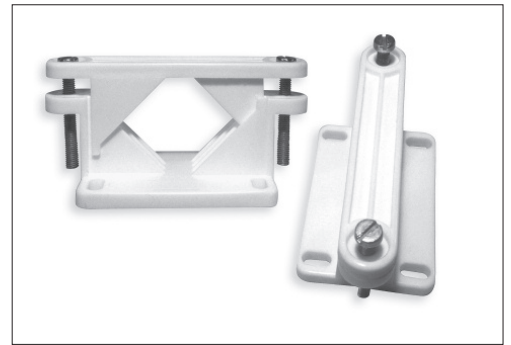
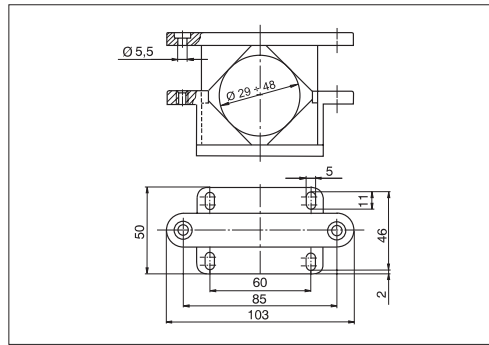

- Application** All-purpose grips are used for stationary power engineering cables and or installation pipes of 29 up to 48 mm. Special shape and the construction make the connection more durable.
- Assembling** The grip's base is screwed down to the foundation with the aid of 4 pcs of wood screws (the grips are sold without the screws). Next the cable or the pipe are fastened to the foundation by means of "grip bridge" equipped in two screws.
- Technical data** The grips are made of polypropylene (BN-79/6364-03).
UV resistant.
Colors: white, black.
Operating temperature from: from -15° to 70°C.

Product name	Index	Packing [pcs.]	Cumulative packing [sets]	Colour
UKU-50-B	WOUUW0011	5	20	white
UKU-50-C	WOUUB0011	5	20	black

Cable ties - type CT (white and black) - type CT

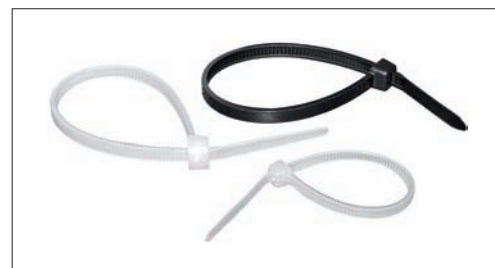
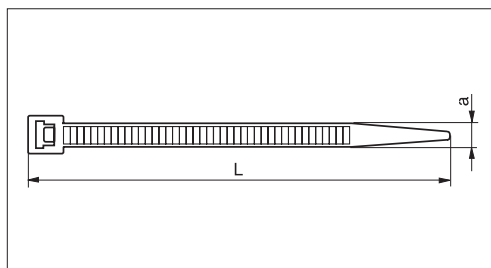
**Application**

Cable ties are used for fastening in the bundle of conductors, tubing, hoses etc. Assembling is easier because of rounded safety edges and terminal.

Technical data

The ties are available in white and black colors (at the end of the ties' name it should be added "C" letter e.g. CT 100-2,5 C). The ties in black color have increased UV resistance.

Cable ties are made of polyamide 6.6.

They don't contain halides of cadmium, mercury, lead and chromium. Inflammability class acc. to UL 94 V2. Operating temperature: from: od -40 do 85°C.

In the connection with specificity of the production dimensions tolerances are as following: length 5%, width 12%.

Up to the dimension of 4,8 cable ties are packed in foil bags by 10 sets and next in cardboard boxes in accordance with the specification.

The strength needed for the tie breaking is given in a unit of strength's kilogram (1kG=9,8N).

Max. diameter of bunch [mm]	Product name	Index (color white)	Index (color black)	Packing [pcs.]	Cumulative packing [pcs.]	Dimensions [mm]		Tensile strength [kG]
						L	a	
15	CT 80-2,4	TOOCW008002401	TOOCB008002401	100	800	80	2,4	8
21	CT 100-2,5	TOOCW010002501	TOOCB010002501	100	700	100	2,5	8
30	CT 120-2,5	TOOCW012002501	TOOCB012002501	100	700	120	2,5	8
40	CT 160-2,5	TOOCW016002501	TOOCB016002501	100	500	160	2,5	8
53	CT 200-2,5	TOOCW020002502	TOOCB020002502	100	400	200	2,5	8
33	CT 140-3,6	TOOCW014003601	TOOCB014003601	100	400	140	3,6	18
53	CT 200-3,6	TOOCW020003602	TOOCB020003602	100	250	200	3,6	18
76	CT 300-3,6	TOOCW030003601	TOOCB030003601	100	200	300	3,6	18
102	CT 370-3,6	TOOCW037003601	TOOCB037003601	100	170	370	3,6	18
24	CT 120-4,8	TOOCW012004801	TOOCB012004801	100	200	120	4,8	22
38	CT 160-4,8	TOOCW016004801	TOOCB016004801	100	230	160	4,8	22
50	CT 200-4,8	TOOCW020004801	TOOCB020004801	100	180	200	4,8	22
60	CT 250-4,8	TOOCW025004801	TOOCB025004801	100	170	250	4,8	22
76	CT 300-4,8	TOOCW030004801	TOOCB030004801	100	140	300	4,8	22
102	CT 370-4,8	TOOCW037004801	TOOCB037004801	100	120	370	4,8	22
110	CT 430-4,8	TOOCW043004801	TOOCB043004801	100	100	430	4,8	22
50	CT 200-7,6	TOOCW020007601	TOOCB020007601	100	100	200	7,6	54
76	CT 292-7,6	TOOCW029207601	TOOCB029207601	100	75	292	7,6	54
102	CT 368-7,6	TOOCW036807601	TOOCB036807601	100	60	368	7,6	54
130	CT 450-7,8	TOOCW045007801	TOOCB045007801	100	50	450	7,8	54
158	CT 540-7,8	TOOCW054007801	TOOCB054007801	100	40	540	7,8	54
195	CT 750-7,8	TOOCW075007802	TOOCB075007802	25	80	750	7,8	54
140	CT 528-9	TOOCW052809002	TOOCB052809002	25	120	528	9,0	79
185	CT 710-9	TOOCW071009002	TOOCB071009002	25	70	710	9,0	79
239	CT 812-9	TOOCW081209002	TOOCB081209002	25	60	812	9,0	79
295	CT 1020-9	TOOCW102009002	TOOCB102009002	25	40	1020	9,0	79
120	CT 480-12,6	TOOCW048012602	TOOCB048012602	25	-	480	12,6	114
204	CT 730-12,6	TOOCW073012602	TOOCB073012602	25	-	730	12,6	114
295	CT 1030-12,6	TOOCW103012602	TOOCB103012602	25	32	1030	12,6	114

Reusable cable ties – CTK type

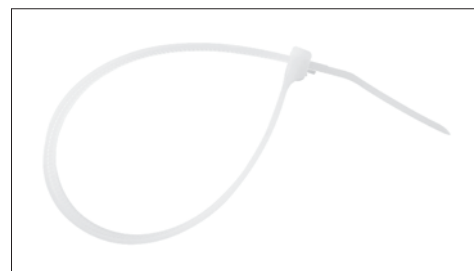
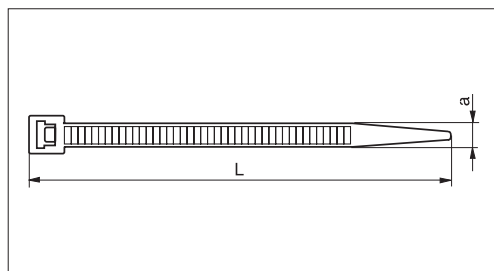
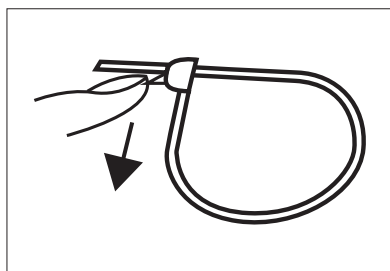
**Application**

They are reusable and serve to connect a bundle of electric wires, tubes, hoses etc. thanks to a zip with a lever for easier unzipping.
Thanks to rounded edges, they assure safe and easy assembly.

Technical data

White color.
Material: polyamide 6.6.
They don't contain halides of cadmium, mercury, lead and chromium.
Assembling temperature: 0 to 40°C.
Operating temperature: from: od -40 do 85°C.
In the connection with specificity of the production dimensions tolerances are as following: length 5%, width 12%.
The strength needed for the tie breaking is given in a unit of strength's kilogram (1kG=9,8N).

Max. diameter of bunch [mm]	Product name	Index	Packing [pcs.]	Dimensions [mm]		Tensile strength [kG]
				L	a	
25	CTK 100-3,6	TOOCW01003602	100	100	3,6	18
54	CTK 200-4,8	TOOCW02004802	100	198	4,8	22
85	CTK 300-4,8	TOOCW03004802	100	301	4,8	22

With assembly eye - type CTO

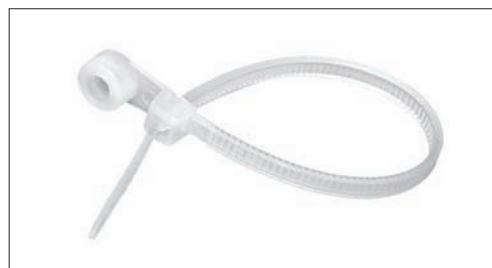
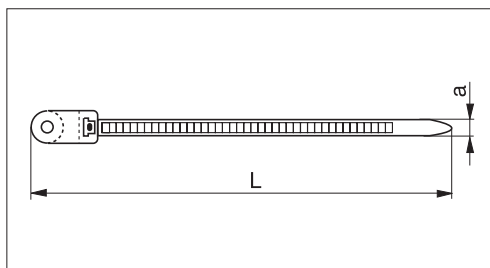
**Application**

Cable ties are used for fastening in the bundle of conductors, tubing, hoses etc. Assembling is easier because of rounded safety edges and terminal.

Technical data

White color.

Material: polyamide 6.6.

They don't contain halides of cadmium, mercury, lead and chromium.

Assembling temperature: 0 to 40°C.

Operating temperature: from: od -40 do 85°C.

In the connection with specificity of the production dimensions tolerances are as following: length 5%, width 12%.

The strength needed for the tie breaking is given in a unit of strength's kilogram (1kG=9,8N).

Max. diameter of bunch [mm]	Product name	Index	Packing [pcs.]	Cumulative packing [pcs.]	Dimensions [mm]		Hole for screw	Tensile strength [kG]
					L	a		
22	CTO 110-2,5	TOOOW011002501	100		110	2,5	M3	8,1
32	CTO 150-3,6	TOOOW015003601	100	150	150	3,6	M4	18,2
50	CTO 200-4,8	TOOOW020004801	100		200	4,8	M5	22,2

With snap grip - type CTZ

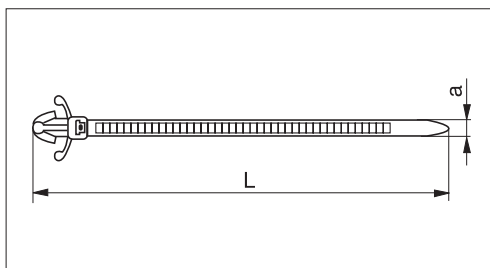
**Application**

Cable ties are used for fastening in the bundle of conductors, tubing, hoses etc. Assembling is easier because of rounded safety edges and terminal.

Technical data

White color.

Material: polyamide 6.6.

They don't contain halides of cadmium, mercury, lead and chromium.

Assembling temperature: 0 to 40°C.

Operating temperature: from: od -40 do 85°C.

In the connection with specificity of the production dimensions tolerances are as following: length 5%, width 12%.

The strength needed for the tie breaking is given in a unit of strength's kilogram (1kG=9,8N).

Max. diameter of bunch [mm]	Product name	Index	Packing [pcs.]	Dimensions [mm]		Hole for screw [mm]	Tensile strength [kG]
				L	a		
25	CTZ 130-4,8	TOOZW013004801	100	130	4,8	6 ÷ 6,5	22,2
45	CTZ 195-4,8	TOOZW019504801	100	195	4,8	6 ÷ 6,5	22,2

With outer identification plate - type CTTZ
 With inner identification plate - type CTTW

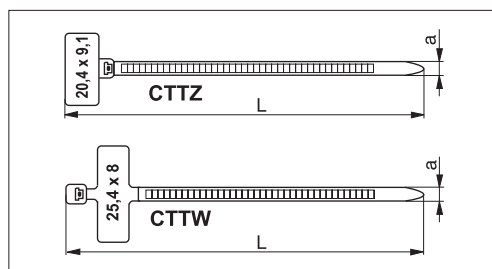
**Application**

Cable ties are used for fastening in the bundle of conductors, tubing, hoses etc. Assembling is easier because of rounded safety edges and terminal.

Technical data

White color.

Material: polyamide 6.6.

They don't contain halides of cadmium, mercury, lead and chromium.

Assembling temperature: 0 to 40°C.

Operating temperature: from: od -40 do 85°C.

In the connection with specificity of the production dimensions tolerances are as following: length 5%, width 12%.

The strength needed for the tie breaking is given in a unit of strength's kilogram (1kG=9,8N).

Max. diameter of bunch [mm]	Product name	Index	Packing [pcs.]	Dimensions [mm]		Tensile strength [kG]
				L	a	
18	CTTZ 110-2,5	TOOTW011002501	100	110	2,5	8,1
50	CTTZ 210-2,5	TOOTW021002501	100	210	2,5	8,1
18	CTTW 100-2,5	TOOWW010002501	100	100	2,5	8,1

Elements fastened in the hole drilled in the foundation - type UMW

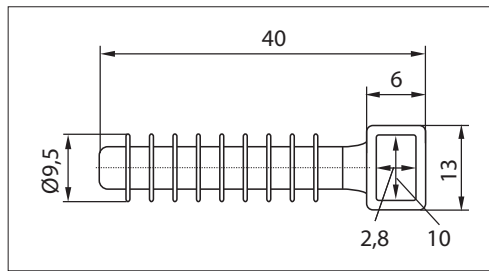
**Application**

Meant for fastening of cable ties to different types of foundations.

Technical data

The elements are made of polyamide 6.6.

Elements in black and white colour have higher resistance to UV radiation.

Operating temperature: from -40°C to +85°C.

Product name	Index	Color	Packing [pcs.]
UMW 10-C	TOM0B0	czarny	100
UMW 10	TOM0W0	biały	100

Elements screwed down to the foundation with the aid of the screw - type UMO

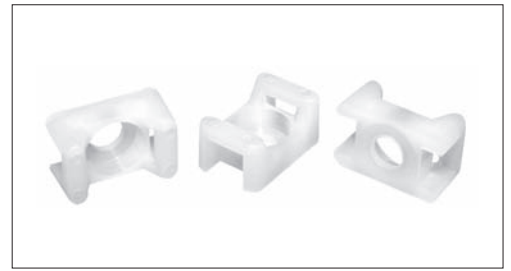
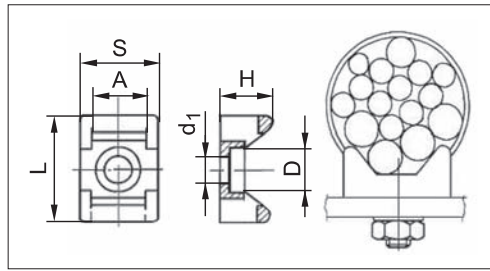

Application Meant for fastening of cable ties to different types of foundations.

Technical data The elements are made of polyamide.
Color: white.
Operating temperature: from -40°C to +85°C.

Product name	Index	Packing [pcs.]	Dimensions [mm]					
			A	D	d ₁	H	S	L
UMO 5	TOM3W1	100	5,0	6,6	3,4	7,2	9,5	14,9
UMO 9	TOM3W2	100	9,0	12,4	6,4	9,7	15,9	21,9

Self-strick elements - type UMS

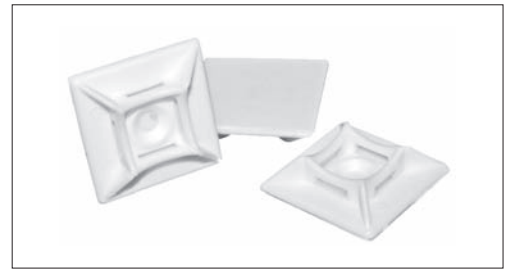
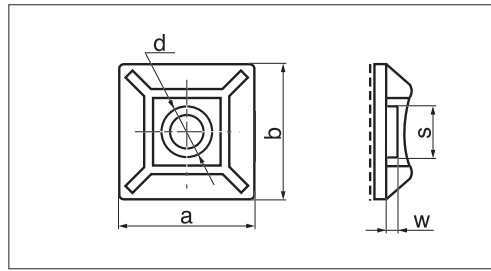

Application Meant for fastening of cable ties to different types of foundations.

Technical data Polyamide body 6.6, white and black.
 Elements in black colour have higher resistance to UV radiation.
 Operating temperature: from -40°C to +70°C.

Product name	Index	Packing [pcs.]	Colour	Max. fixed loading [g]	Dimensions				
					a [mm]	b [mm]	d [mm]	s [mm]	w [mm]
UMS 12	TOM9W1	100	white	40	12,5	12,5	bez	3,0	1,5
UMS 12-C	TOM9B1	100	black	40	12,5	12,5	bez	3,0	1,5
UMS 19	TOM9W2	100	white	100	19,0	19,0	4,0	4,0	1,5
UMS 19-C	TOM9B2	100	black	100	19,0	19,0	4,0	4,0	1,5
UMS 28	TOM9W0	100	white	260	28,0	28,0	6,0	5,0	1,5
UMS 28-C	TOM9B0	100	black	260	28,0	28,0	6,0	5,0	1,5

Electro-insulating tapes - type AR



Application Universal, self-extinguishing tapes are supplied for using in places where very well insulation properties are required. Ideal for using in industrial and domestic installations. Perfect for the applications in household and industrial installations. They are very well self-adhesive, flexible, sealing and have high resistance to moisture penetration, chemicals and abrasion. They are applied for the reproduction of cables and conductors insulation, bundling, phase marking, electrolytic corrosion protection, sealing, packing and so on.

Assembling Tape shall be winded by stretching of 20%. In order that guard against the deglutination of tape; the last braid shall be made without the tension. We recommend to wind the tape in the room temperature. The surface on which the tape will be fastened should be clean, dry and free of grease and oil.

Storage Tapes should be protected against direct sunlight, sudden temperature changes, dust which may pollute the glue layer. Store not longer than 1 year.

Technical data

rupture strength	≥ 18 N/cm,
elongation at rupture	≥ 160%,
adhesion on steel	≥ 1,6 N/cm,
brakdown voltage	≥ 4,8 kV,
flame duration	≤ 3 s, acc. with UL 510
temperature grade	from -12 to +80°C,
thickness tolerance	± 5%,
width tolerance	± 1 mm,
length tolerance	± 10%.

Product name	Index	Color	Packing [pcs.]	Cumulative packing [sets]	length [m]	Dimensions width [mm]	thickness [mm]
AR 15/10-RM	TTENK1510RM0	mix	10	36	10	15	0,13
AR 15/10-C	TTENK1510C00	black	10	36	10	15	0,13
AR 19/10-RM	TTENK1910RM0	mix	10	25	10	19	0,13
AR 19/10-C	TTENK1910C00	black	10	25	10	19	0,13
AR 19/20-RM	TTENK1920RM0	mix	10	20	20	19	0,13
AR 19/20-C	TTENK1920C00	black	10	20	20	19	0,13
AR 19/20-K	TTENK1920K00	red	10	20	20	19	0,13
AR 19/20-T	TTENK1920T00	green	10	20	20	19	0,13
AR 19/20-Z	TTENK1920Z00	yellow	10	20	20	19	0,13
AR 19/20-ZT	TTENK1920ZT0	yellow-green	10	20	20	19	0,13
AR 19/20-N	TTENK1920N00	blue	10	20	20	19	0,13
AR 19/20-SZ	TTENK1920SZ0	gray	10	20	20	19	0,13
AR 19/20-B	TTENK1920B00	white	10	20	20	19	0,13
AR 19/20-BR	TTENK1920BR0	brown	10	20	20	19	0,13
AR 19/20-F	TTENK1920F00	purple	10	20	20	19	0,13
AR 50/20-C	TTENK5020C00	black	1	80	20	50	0,13

Cable glands, polyamide - type DR ... NP2

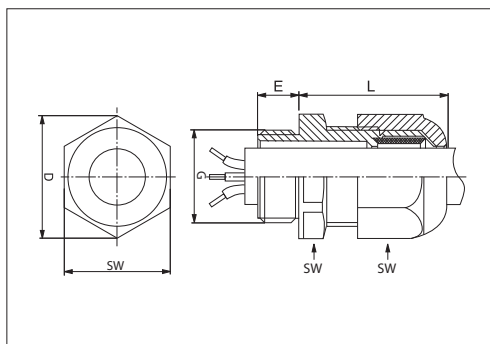
**Application**

They are meant for sealing of conductor passages e.g. in switchboards.
Cable glands guarantee high level of protection against strange solid bodies and water penetration.
Supplied with polyamide nut and sealing washer.

Technical data

Housing material: poliamid PA 6, Grey Colour RAL 7035
Material seal: neopren
Continuous working temperature: -20 to 100 °C
Interim Operating temperature: -30 to 150 °C
Flammability class UL 94 V2
UV Resistance
Protection degree: IP 68 (dustproof, protection in case of immersion in water up to depth of 1m)
Type of thread: **Pg** - standard UTE C 68-311 - DIN 40430
M - (metric, ISO) - wg EN 60423 i EN 50262

Product name	Thread type	Index	Dimensions [mm]					Conductor diameter from - to [mm]	Packing [pcs.]
			G	E	L max	D	SW		
DR 7 NP2	Pg 7	TODP07N5	13	8	22	17,1	15	3 - 6,5	100
DR 9 NP2	Pg 9	TODP09N5	16	8	25	21,6	19	4 - 8	50
DR 11 NP2	Pg 11	TODP11N5	19	8	28	25	22	5 - 10	50
DR 13 NP2	Pg 13,5	TODP13N5	21	9	29	27,8	24	6 - 12	50
DR 16 NP2	Pg 16	TODP16N5	23	10	31	30,8	27	10 - 14	50
DR 21 NP2	Pg 21	TODP21N5	29	11	35	37,8	33	13 - 18	25
DR 29 NP2	Pg 29	TODP29N5	37	11	40	48	42	18 - 25	20
DR 36 NP2	Pg 36	TODP36N5	47	13	49	60	53	22 - 32	10
DR 42 NP2	Pg 42	TODP42N5	54	13	49	67,7	60	30 - 38	10
DR 48 NP2	Pg 48	TODP48N5	59	14	49	72,2	65	34 - 44	10
DR 12M NP2	M12x1,5	TODM12N5	12	8	22	17,1	15	3 - 6,5	100
DR 16M NP2	M16x1,5	TODM16N5	16	10	28	25	22	5 - 10	50
DR 20M NP2	M20x1,5	TODM20N5	20	10	29	27,8	24	6 - 12	50
DR 25M NP2	M25x1,5	TODM25N5	25	10	35	37,8	33	13 - 18	25
DR 32M NP2	M32x1,5	TODM32N5	32	18	40	48	42	18 - 25	20
DR 40M NP2	M40x1,5	TODM40N5	40	18	49	60	53	22 - 32	10
DR 50M NP2	M50x1,5	TODM50N5	50	18	49	67,7	60	30 - 38	10
DR 63M NP2	M63x1,5	TODM63N5	63	18	49	72,2	65	34 - 44	10

Press: PMI 1-6, PMW 1-6, PMH 1-6, PMN 1-10



Immobile lower jaw and almost parallel tighten of upper jaw guarantee precise crimping.

Construction of body guarantee proper device stiffness. Tempered jaws (HRC 42 ÷ 48) made of steel ensure very high durability of the device. User-friendly hands protect against direct contact of user's hands with metal elements of the tool. They are made of material which guard against hands deslize thanks to it the long-lasting work with the press is easier.

Weight: 0,6 kg.

LI, VI, JB, JC, JE, ZKIT
0,5 ÷ 6 mm²



Press PMI 1-6

Designed for crimping insulated terminals and ferrules for wires cross-sections from 0,5 ÷ 6 mm².

The press can be also used for crimping heat shrink insulated terminals and ferrules thanks to jaws' round edges.

uninsultaded female connectors
0,5 ÷ 6 mm²

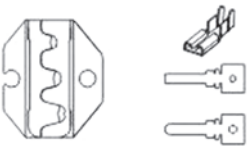

Press PMW 1-6

Designed for crimping of uninsulated male and female connectors for wires cross-sections 0,5 ÷ 6 mm².

AS, AI
0,5 ÷ 6 mm²

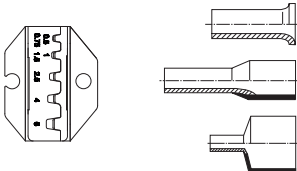

Press PMH 1-6

Meant for crimping of tubular terminals AS, AL, dedicated to termination and protection of multiple-wire cores for cross-sections 0,5 ÷ 6 mm².

K, Z, LG, LZ, VG
0,5 ÷ 10 mm²

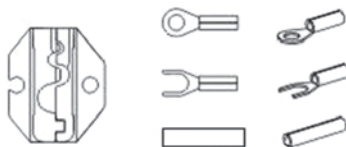

Press PMN 1-10

Designed for crimping of uninsulated ring and spade terminals and cable connectors for cross-sections 0,5 ÷ 10 mm².



Press PMA 10-35

Meant for crimping of tubular terminals AS, AL, dedicated to termination and protection of multiple-wire cores for cross-sections 10 ÷ 35 mm².

Weight: 0,31 kg.

Vibroisolators type UC

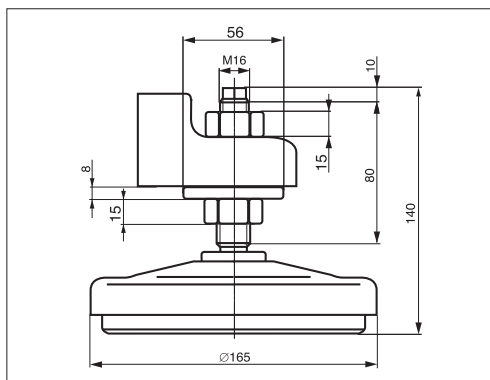

Application

Vibroisolators are supplied for the precise and foundationless foundation of machines and devices. They act in two ways: insulate the environment from vibration evoked by running machines (active vibration), insulate the machine from vibration and shocks caused by the environment, for instance: the vibration transmitted through by floor, evoked by others machines (passive vibration). They decrease efficaciously the noise, vibration and blows level, improving the environment protection conditions, and industrial safety. Thanks to them, the production management costs are lowered, for instance: cost of special floor execution. The advantage is shorter assembling and location changes of machines. This vibroisolators extend the machines and objects life. Easy using.

Construction

UC vibroisolator consists of two cardinal parts: metal (cap and special screw), flexible (settling disk and rings). Suitable construction of cap causes the transmission of static and dynamic forces on total surface and guarantees no deformation of the cap as the result of fatigue. Irregularity of surface under the machine is liquidated with the aid of screw cap control and thrust washer. The rings are made of rubber resistant for oil and greases. They have different degree of hardness (50°Sh and 70°Sh) depends on type of vibroisolator. Metal elements have corrosion protection.

Screw dimensions

Standard screws used for vibroisolators have dimension M16, caps M16 have length 15 mm. Standard working length of screw M16 is 80 mm.

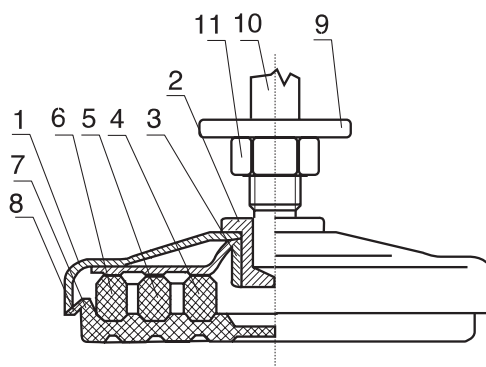

Drawing description:

- 1 - complete cap,
- 2 - resistance seat,
- 3 - sleeve,
- 4, 5, 6 - rubber rings,
- 7 - settling disk,
- 8 - retainer ring,
- 9 - thrust washer,
- 10 - special screw,
- 11 - nut.

- | - vibroisolator axis
- - ring
- - without ring

	Load on one vibroisolator [kg]*		Product name	Cumulative packing [sets]	Rings system
	minimal	maximal			
	100	400	UC 1.1	10	○ ● ● ● ● ○
	200	500	UC 1.2	10	● ● ○ ○ ● ●
	300	800	UC 1.3	10	● ● ● ● ● ●
	300	1000	UC 1.4	10	○ ● ● ● ● ○
	400	1400	UC 1.5	10	● ● ○ ○ ● ●
	500	2000	UC 1.6	10	● ● ● ● ● ●

* recommended load necessary for effective vibrations deaden.

RADPOL

inspired by energy



HEAT-SHRINKABLE TECHNOLOGY



SPUN CONCRETE POLES



PIPE SOLUTIONS



PRE-INSULATED SYSTEMS



POWER TRANSMISSION INSULATORS